



TOWN OF GOLDEN BEACH

**One Golden Beach Drive
Golden Beach, FL 33160**

**Official Agenda for the February 20, 2018
Regular Town Council Meeting called for 7:00 P.M.**

A. MEETING CALLED TO ORDER

B. ROLL CALL

C. PLEDGE OF ALLEGIANCE

D. PRESENTATIONS / TOWN PROCLAMATIONS

RESIDENT SURVEY RESULTS PRESENTATION – RESIDENT
SERVICES DIRECTOR MICHAEL GLIDDEN

E. MOTION TO SET THE AGENDA

ADDITIONS/ DELETIONS/ REMOVAL OF ITEMS FROM CONSENT
AGENDA/ AND CHANGES TO AGENDA

F. GOOD AND WELFARE

G. MAYOR'S REPORT

H. COUNCIL COMMENTS

I. TOWN MANAGER REPORT

J. TOWN ATTORNEY REPORT

K. ORDINANCES – SECOND READING

1. An Ordinance of the Town Council Amending the Town's Code Related to Rooftop Activities.

AN ORDINANCE OF THE TOWN OF GOLDEN BEACH, FLORIDA, AMENDING THE TOWN'S CODE OF ORDINANCES TO REVISE CHAPTER 66, "ZONING," BY AMENDING THE TITLE OF DIVISION 11 "ACCESSORY BUILDINGS: AND BY AMENDING SECTION 66-261 RELATED TO ROOFTOP ACTIVITIES; PROVIDING FOR SEVERABILITY; PROVIDING FOR CODIFICATION; PROVIDING FOR CONFLICTS; AND PROVIDING AN EFFECTIVE DATE.

Exhibit: Agenda Report No. 1
Ordinance No. 577.18

Sponsor: Town Administration

Recommendation: Motion to Approve Ordinance No. 577.18

2. An Ordinance of the Town Council Amending the Town's Code Related to Community Design Standards.

AN ORDINANCE OF THE TOWN OF GOLDEN BEACH, FLORIDA, AMENDING THE TOWN'S CODE OF ORDINANCES RELATED TO COMMUNITY DESIGN STANDARDS; AMENDING SECTION 66-137 OF THE ZONING CODE RELATED TO ACCEPTABLE PAINT COLORS; PROVIDING FOR SEVERABILITY; PROVIDING FOR CODIFICATION; AND PROVIDING AN EFFECTIVE DATE.

Exhibit: Agenda Report No. 2
Ordinance No. 578.18

Sponsor: Town Administration

Recommendation: Motion to Approve Ordinance No. 578.18

L. ORDINANCES - FIRST READING

None

M. QUASI JUDICIAL RESOLUTIONS

None

N. CONSENT AGENDA

3. Official Minutes of the January 23rd, 2018 Special Town Council Meeting
4. A Resolution of the Town Council Approving the Establishment of a Retirement Health Savings Plan for the Employees of the Town.

A RESOLUTION OF THE TOWN OF GOLDEN BEACH, FLORIDA, ESTABLISHING A RETIREMENT HEALTH SAVINGS PROGRAM FOR EMPLOYEES TO ASSIST WITH MEDICAL EXPENSES UPON RETIREMENT; AUTHORIZING MATCH FUNDING AND THE USE OF LEAVE BENEFITS; AUTHORIZING TOWN OFFICIALS TO TAKE ALL ACTIONS NECESSARY TO OFFER A RETIREMENT HEALTH SAVINGS PROGRAM;

AUTHORIZING THE EXPENDITURE OF BUDGETED FUNDS; AND PROVIDING FOR AN EFFECTIVE DATE

Exhibit: Agenda Report No. 4
Resolution No. 2543.18

Sponsor: Town Administration

Recommendation: Motion to Approve Resolution No. 2543.18

O. TOWN RESOLUTIONS

5. A Resolution of the Town Council Approving Enhancements to the Town's Parks.

A RESOLUTION OF THE TOWN COUNCIL OF THE TOWN OF GOLDEN BEACH, FLORIDA, ACCEPTING THE TOWN MANAGER'S RECOMMENDATIONS PERTAINING TO THE TOWN'S PARKS; PROVIDING FOR AUTHORIZATION FOR THE TOWN MANAGER TO IMPLEMENT THE PROGRAM IN THE MANNER DESCRIBED; AND PROVIDING FOR AN EFFECTIVE DATE.

Exhibit: Agenda Report No. 5
Resolution No. 2544.18

Sponsor: Town Administration

Recommendation: Motion to Approve Resolution No. 2544.18

6. A Resolution of the Town Council Authorizing A Proposal from Bejar Construction, Inc. for Renovation of the Town's Beach Pavilion.

A RESOLUTION OF THE TOWN COUNCIL OF THE TOWN OF GOLDEN BEACH, FLORIDA APPROVING A PROPOSAL FROM BEJAR CONSTRUCTION, INC. FOR RENOVATION OF THE TOWN'S BEACH PAVILION; PROVIDING FOR A WAIVER OF COMPETITIVE BIDDING PROCEDURES; PROVIDING FOR IMPLEMENTATION; PROVIDING FOR AUTHORIZATION; AND PROVIDING FOR AN EFFECTIVE DATE.

Exhibit: Agenda Report No. 6
Resolution No. 2545.18

Sponsor: Town Administration

Recommendation: Motion to Approve Resolution No. 2545.18

7. A Resolution of the Town Council Authorizing a Proposal from Bejar Construction, Inc. for Improvements to the Town's Entry Feature.

A RESOLUTION OF THE TOWN COUNCIL OF THE TOWN OF GOLDEN BEACH, FLORIDA APPROVING A PROPOSAL FROM BEJAR CONSTRUCTION, INC. FOR REPAIRS AND IMPROVEMENTS TO THE TOWN'S ENTRY FEATURE; PROVIDING FOR A WAIVER OF COMPETITIVE BIDDING PROCEDURES; PROVIDING FOR IMPLEMENTATION; PROVIDING FOR AUTHORIZATION; AND PROVIDING FOR AN EFFECTIVE DATE.

Exhibit: Agenda Report No. 7
Resolution No. 2546.18

Sponsor: Town Administration

Recommendation: Motion to Approve Resolution No. 2546.18

8. A Resolution of the Town Council Supporting the Reenactment of the Federal Assault Weapons Ban.

A RESOLUTION OF THE TOWN COUNCIL OF THE TOWN OF GOLDEN BEACH, FLORIDA, SUPPORTING THE REENACTMENT OF THE FEDERAL ASSAULT WEAPONS BAN; DEMANDING THAT THE FLORIDA LEGISLATURE AND GOVERNOR TO ENACT ITS OWN BAN ON ASSAULT WEAPONS; PROVIDING FOR IMPLEMENTATION AND AN EFFECTIVE DATE.

Exhibit: Agenda Report No. 8
Resolution No. 2547.18

Sponsor: Town Administration

Recommendation: Motion to Approve Resolution No. 2547.18

9. A Resolution of the Town Council Approving Amendment #1 to the 2017-2018 Operating Budget.

A RESOLUTION OF THE TOWN COUNCIL OF THE TOWN OF GOLDEN BEACH, FLORIDA, APPROVING AMENDMENT #1 TO THE 2017-2018 FISCAL YEAR OPERATING BUDGET; PROVIDING FOR IMPLEMENTATION; AND PROVIDING FOR AN EFFECTIVE DATE.

Exhibit: Agenda Report No. 9
Resolution No. 2548.18

Sponsor: Town Administration

Recommendation: Motion to Approve Resolution No. 2548.18

P. DISCUSSION & DIRECTION TO TOWN MANAGER

Mayor Glenn Singer:
None Requested

Vice Mayor Judy Lusskin:
None Requested

Councilmember Kenneth Bernstein:
None Requested

Councilmember Amy Isackson-Rojas:
None Requested

Councilmember Jaime Mendal:
None Requested

Town Manager Alexander Diaz:
None Requested

Q. ADJOURNMENT:

DECORUM:

ANY PERSON MAKING IMPERTINENT OR SLANDEROUS REMARKS OR WHO BECOMES BOISTEROUS WHILE ADDRESSING THE COUNCIL SHALL BE BARRED FROM THE COUNCIL CHAMBERS BY THE PRESIDING OFFICER. NO CLAPPING, APPLAUDING, HECKLING OR VERBAL OUTBURSTS IN SUPPORT OR OPPOSITION TO A SPEAKER OR HIS OR HER REMARKS SHALL BE PERMITTED. NO SIGNS OR PLACE CARDS SHALL BE ALLOWED IN THE COUNCIL CHAMBERS. PERSONS EXITING THE COUNCIL CHAMBERS SHALL DO SO QUIETLY.

THE USE OF CELL PHONES IN THE COUNCIL CHAMBERS IS NOT PERMITTED. RINGERS MUST BE SET TO SILENT MODE TO AVOID DISRUPTION OF PROCEEDINGS.

PURSUANT TO FLORIDA STATUTE 286.0105, THE TOWN HEREBY ADVISES THE PUBLIC THAT: IF A PERSON DECIDES TO APPEAL ANY DECISION MADE BY THIS BOARD WITH RESPECT TO ANY MATTER CONSIDERED AT ITS MEETING OR HEARING, HE WILL NEED A RECORD OF THE PROCEEDINGS, AND FOR THAT PURPOSE, AFFECTED PERSONS MAY NEED TO ENSURE THAT A VERBATIM RECORD OF THE PROCEEDINGS IS MADE, WHICH RECORD SHALL INCLUDE THE TESTIMONY AND EVIDENCE UPON WHICH THE APPEAL IS TO BE BASED. THIS NOTICE DOES NOT CONSTITUTE CONSENT BY THE TOWN FOR THE INTRODUCTION OR ADMISSION OF OTHER INADMISSIBLE OR IRRELEVANT EVIDENCE, NOR DOES IT AUTHORIZE CHALLENGES OR APPEALS NOT OTHERWISE ALLOWED BY LAW.

IF YOU NEED ASSISTANCE TO ATTEND THIS MEETING AND PARTICIPATE, PLEASE CALL THE TOWN MANAGER AT 305-932-0744 EXT 224 AT LEAST 24 HOURS PRIOR TO THE MEETING.

RESIDENTS AND MEMBERS OF THE PUBLIC ARE WELCOMED AND INVITED TO ATTEND.



TOWN OF GOLDEN BEACH

One Golden Beach Drive
Golden Beach, FL 33160

MEMORANDUM

Date: February 20, 2018

To: Honorable Mayor Glenn Singer &
Town Council Members

From: Alexander Diaz,
Town Manger

A handwritten signature in blue ink that reads "Alex B." with a stylized flourish at the end.

Subject: Ordinance No. 577.18 – Amending Code, Division 11,
“Accessory Building”, Section 66-261 – Rooftop Activities

Item Number:

1

Recommendation:

It is recommended that the Town Council adopt the attached Ordinance No. 577.18 as presented.

Background:

At First Reading, by your action, you directed staff to include language pertaining to permissible use, specifically allowing for a single water amenity. This ordinance provides that the Building Regulatory Advisory Board must approve the amenity.

Fiscal Impact:

None.

TOWN OF GOLDEN BEACH, FLORIDA

ORDINANCE NO. 577.18

AN ORDINANCE OF THE TOWN OF GOLDEN BEACH, FLORIDA, AMENDING THE TOWN'S CODE OF ORDINANCES TO REVISE CHAPTER 66, "ZONING," BY AMENDING THE TITLE OF DIVISION 11 "ACCESSORY BUILDINGS; AND BY AMENDING SECTION 66-261 RELATED TO ROOFTOP ACTIVITIES; PROVIDING FOR SEVERABILITY; PROVIDING FOR CODIFICATION; PROVIDING FOR CONFLICTS; AND PROVIDING AN EFFECTIVE DATE.

1 **WHEREAS**, the Town Council periodically studies land development trends and
2 issues and amends the Town's Land Development Regulations accordingly; and

3 **WHEREAS**, the Town Council has studied the current Code provisions of the Town
4 and found that certain modifications are necessary and desirable to further regulate rooftop
5 activities and uses, including rooftop elevator vestibules and exterior staircases on single-
6 family homes; and

7 **WHEREAS**, a public meeting was held before the Local Planning Agency (LPA) of
8 the Town to review the proposed modifications to the Town's Land Development
9 Regulations; and

10 **WHEREAS**, the Town Council held duly advertised public meetings to consider the
11 proposed modifications to the Town's Land Development Regulations.

12 **NOW, THEREFORE, BE IT ORDAINED BY THE TOWN COUNCIL OF GOLDEN**
13 **BEACH, FLORIDA:**

14 **Section 1. Recitals Adopted.** That the preceding "Whereas" clauses are
15 ratified and incorporated as a record of the legislative intent of this Ordinance.

16 **Section 2. Code Amended.** That the Town of Golden Beach Code is hereby
17 amended to modify Division 11. “Accessory Buildings,” of Article IV, “Supplemental District
18 Regulations,” of Chapter 66, “Zoning” as follows¹:

19 **CHAPTER 66 ZONING**

20 * * *

21 **ARTICLE IV. SUPPLEMENTAL DISTRICT REGULATIONS**

22 * * *

23 **DIVISION 11. ACCESSORY BUILDINGS AND USES**

24 * * *

25 **Sec. 66-261. – Rooftop activities.**

- 26
- 27
- 28 (a) Except as specified below in this Section, the use of the roof of a residential
29 structure for passive leisure ~~habitable~~ activities, including, but not limited to,
30 entertainment and other leisure and recreational activities, is prohibited.
- 31
- 32 (b) Within Zone One, the roof of the highest roofed structure may be used
33 for passive leisure ~~habitable~~ activities, including entertainment and other passive
34 recreational / leisure uses subject to the following limitations:
- 35
- 36 (1) The lot must be at least 7,500 square feet in area.
- 37
- 38 (2) The usable area must be set back a minimum of ten feet from the edge of
39 the roof in all directions except from the rear (ocean front).
- 40
- 41 (3) The rooftop area shall not be improved with any permanent structures or the
42 placement of any temporary or permanent fixtures or equipment except a
43 safety railing up to 48 inches in height. Outdoor furniture such as chairs,
44 sofas, and tables, and pots and planters are permitted. Additionally, with the
45 approval of the Building Regulatory Advisory Board, a single water amenity
46 (i.e. a hot tub/spa) may be placed on the rooftop.
- 47
- 48 (4) No amplified or live music shall be permitted on the roof.
- 49
- 50 (5) ~~The~~ An elevator and any covered elevator vestibule serving the rooftop shall
51 be limited to an area of no more than ~~five feet by ten feet~~ 110 square
52 feet. Any elevator and any covered elevator vestibule, if permitted, shall be
53 placed near the center of the rooftop, but not less than 7.5 feet from the edge
54 of the roof on lots less than 75 feet in width, or less than 10 feet from the
55 edge of the roof on lots 75 feet or more in width.
- 56

¹ Additions to the text are shown in underline. Deletions to the text are shown in ~~striketrough~~.

57 (6) Staircases may extend from lower floors or the ground level to the rooftop,
58 but must comply with the setback and yard projection provisions set forth in
59 Sec. 66-141(b). Safety railings up to 48 inches in height for staircases are
60 allowed, provided they meet the above setback and yard projections. Once
61 at the rooftop railings must terminate at or connect directly to any railings
62 surrounding the usable passive leisure activity area set forth in subsection
63 (2) above. Any portion of a staircase railing constructed above the rooftop
64 shall be designed with an open appearance (no walls).
65

66 * * *

67 **Section 3. Code Amended.** That is any section, paragraph, sentence or word
68 of this Ordinance or the application thereof to any person or circumstance is held invalid,
69 that the invalidity shall not affect the other sections, paragraphs, sentences, words or
70 application of this Ordinance.

71 **Section 4. Codification.** That it is the intention of the Town Council of Golden
72 Beach, and it is therefore ordained, that the provisions of the Ordinance shall become and
73 be made a part of the Town of Golden Beach Code of Ordinances, that sections of this
74 Ordinance may be re-numbered or re-lettered to accomplish such intentions, and that the
75 word "Ordinance" shall be changed to "Section" or other appropriate word.

76 **Section 5. Repealer.** That all Ordinances, parts of Ordinances, Resolutions or
77 parts of Resolutions in conflict herewith be and the same are hereby repealed to the extent
78 of such conflict.

79 **Section 6. Effective Date.** That this Ordinance shall be in full force and take
80 effect immediately upon its passage and adoption.

81 The Motion to adopt the foregoing Ordinance was offered by Vice Mayor
82 Luskin, seconded by Councilmember Bernstein, and on roll call the following vote
83 ensued:

84	Mayor Glenn Singer	<u>Aye</u>
85	Vice-Mayor Judy Luskin	<u>Aye</u>
86	Councilmember Amy Isackson-Rojas	<u>Absent</u>
87	Councilmember Kenneth Bernstein	<u>Aye</u>
88	Councilmember Jaime Mendal	<u>Aye</u>
89		

90
91
92
93
94
95
96
97
98
99
100
101
102
103
104
105
106
107
108
109
110
111
112
113
114
115
116
117
118
119

PASSED AND ADOPTED on first reading this 23rd day of January, 2018.

The Motion to adopt the foregoing Ordinance was offered by _____,

seconded by _____, and on roll call the following vote ensued:

Mayor Glenn Singer _____
Vice-Mayor Judy Lusskin _____
Councilmember Amy Isackson-Rojas _____
Councilmember Kenneth Bernstein _____
Councilmember Jaime Mendal _____

PASSED AND ADOPTED on second reading this 20th day of February,

2018.

ATTEST:

MAYOR GLENN SINGER

LISSETTE PEREZ
TOWN CLERK

APPROVED AS TO FORM
AND LEGAL SUFFICIENCY:

STEPHEN J. HELFMAN
TOWN ATTORNEY



TOWN OF GOLDEN BEACH

One Golden Beach Drive
Golden Beach, FL 33160

MEMORANDUM

Date: February 20, 2018

To: Honorable Mayor Glenn Singer &
Town Council Members

From: Alexander Diaz,
Town Manger

A handwritten signature in blue ink that reads "Alex B." with a circled "B".

Subject: Ordinance No. 578.18 – Amending Code, Section 66-137 –
Community Design Standards

Item Number:

2

Recommendation:

It is recommended that the Town Council adopt the attached Ordinance No. 578.18 as presented.

Background:

No changes have been made to this Ordinance since First Reading. Readers are to refer to the original recommendations for further explanation found in the backup documents from the Special Town Council Meeting on January 23rd, 2017.

Fiscal Impact:

None.

TOWN OF GOLDEN BEACH, FLORIDA

ORDINANCE NO. 578.18

AN ORDINANCE OF THE TOWN OF GOLDEN BEACH, FLORIDA, AMENDING THE TOWN'S CODE OF ORDINANCES RELATED TO COMMUNITY DESIGN STANDARDS; AMENDING SECTION 66-137 OF THE ZONING CODE RELATED TO ACCEPTABLE PAINT COLORS; PROVIDING FOR SEVERABILITY; PROVIDING FOR CODIFICATION; AND PROVIDING AN EFFECTIVE DATE.

1 **WHEREAS**, the Town Council periodically studies land development trends and
2 issues and amends the Town's Land Development Regulations accordingly; and

3 **WHEREAS**, in 2017, the Florida Legislature created Florida Statutes Section
4 166.0483 which preempts a local government's ability to require painting permits; and

5 **WHEREAS**, the Town Council has studied the current Code provisions of the Town
6 and finds that certain modifications are necessary and desirable to regulate paint colors in
7 the community in accordance with state law; and

8 **WHEREAS**, a public meeting was held before the Local Planning Agency (LPA) of
9 the Town to review the proposed modifications to the Town's Land Development
10 Regulations; and

11 **WHEREAS**, the Town Council held duly advertised public meetings to consider the
12 proposed modifications to the Town's Land Development Regulations.

13 **NOW, THEREFORE, BE IT ORDAINED BY THE TOWN COUNCIL OF GOLDEN**
14 **BEACH, FLORIDA:**

15 **Section 1. Recitals Adopted.** That the preceding "Whereas" clauses are
16 ratified and incorporated as a record of the legislative intent of this Ordinance.

17 **Section 2.** **Code Amended.** That the Town of Golden Beach Code is hereby
18 amended to modify Division 4. “Design Standards,” of Article IV, “Supplemental District
19 Regulations,” of Chapter 66, “Zoning” as follows¹:

20 **CHAPTER 66 ZONING**

21 * * *

22 **ARTICLE IV. SUPPLEMENTAL DISTRICT REGULATIONS**

23 * * *

24 **DIVISION 4. DESIGN STANDARDS**

25 * * *

26 **Sec. 66-137. – Paint Colors /~~Permit~~ Review Process.**

27 (a) *Paint colors.* No exterior of any Structure may be painted, stained, or otherwise
28 colorized with a color(s) other than a color(s) that is the same or substantially similar to
29 a color within a paint ~~palate~~ palette established and approved by the Town Council. All
30 colors, including accent colors, must be complimentary and harmonious with other
31 materials and components, including roof tiles incorporated into the Structure. Any
32 variation from this standard shall be subject to the ~~zoning review~~Town Building Official's
33 ~~prior approval~~, or the Town's Building Regulation Advisory Board's approval on appeal
34 of the ~~zoning review~~Building Official's decision.

35 (b) *Paint ~~permit~~ color review process.* A ~~Town paint permit shall be required prior~~
36 ~~to painting or repainting of the exterior of any Structure.~~ Any person wishing to paint the
37 exterior of a structure shall submit the proposed paint color sample(s), together with a
38 form prepared by the Town intended to provide information as to the site location, property
39 owner, painting contractor (if any), and proposed areas where the paint is intended to be
40 applied (illustrations / photos), to the Building Department who shall review the proposal

¹ Additions to the text are shown in underline. Deletions to the text are shown in ~~striethrough~~.

41 and verify the proposed color(s) are the same as or substantially similar to the Town's
42 approved color palette. Failure to utilize color(s) verified by the Building Department, in
43 the manner proposed during the review, shall be a violation of this section. If the
44 requested colors are not consistent with the Town's approved color palette, new color(s)
45 shall be selected and reviewed.

46 * * *

47 **Section 3. Code Amended.** That is any section, paragraph, sentence or word
48 of this Ordinance or the application thereof to any person or circumstance is held invalid,
49 that the invalidity shall not affect the other sections, paragraphs, sentences, words or
50 application of this Ordinance.

51 **Section 4. Codification.** That it is the intention of the Town Council of Golden
52 Beach, and it is therefore ordained, that the provisions of the Ordinance shall become and
53 be made a part of the Town of Golden Beach Code of Ordinances, that sections of this
54 Ordinance may be re-numbered or re-lettered to accomplish such intentions, and that the
55 word "Ordinance" shall be changed to "Section" or other appropriate word.

56 **Section 5. Repealer.** That all Ordinances, parts of Ordinances, Resolutions or
57 parts of Resolutions in conflict herewith be and the same are hereby repealed to the extent
58 of such conflict.

59 **Section 6. Effective Date.** That this Ordinance shall be in full force and take
60 effect immediately upon its passage and adoption.

61 The Motion to adopt the foregoing Ordinance was offered by Councilmember
62 Mendal, seconded by Councilmember Bernstein, and on roll call the following vote
63 ensued:

64	Mayor Glenn Singer	<u>Aye</u>
65	Vice-Mayor Judy Lusskin	<u>Aye</u>
66	Councilmember Amy Isackson-Rojas	<u>Absent</u>
67	Councilmember Kenneth Bernstein	<u>Aye</u>
68	Councilmember Jaime Mendal	<u>Aye</u>

69
70
71
72
73
74
75
76
77
78
79
80
81
82
83
84
85
86
87
88
89
90
91
92
93
94
95
96
97

PASSED AND ADOPTED on first reading this 23rd day of January, 2018.

The Motion to adopt the foregoing Ordinance was offered by _____.

seconded by _____, and on roll call the following vote ensued:

Mayor Glenn Singer	_____
Vice-Mayor Judy Lusskin	_____
Councilmember Amy Isackson-Rojas	_____
Councilmember Kenneth Bernstein	_____
Councilmember Jaime Mendal	_____

PASSED AND ADOPTED on second reading this 20th day of February, 2018.

ATTEST:

MAYOR GLENN SINGER

LISSETTE PEREZ
TOWN CLERK

APPROVED AS TO FORM
AND LEGAL SUFFICIENCY:

STEPHEN J. HELFMAN
TOWN ATTORNEY



TOWN OF GOLDEN BEACH

One Golden Beach Drive
Golden Beach, FL 33160

MEMORANDUM

Date: February 20, 2018

To: Honorable Mayor Glenn Singer &
Town Council Members

From: Lissette Perez, 
Town Clerk

Subject: **Town Council Minutes**

Item Number:

3

Recommendation:

It is recommended that the Town Council adopt the attached minutes of the January 23, 2018 Special Town Council Meeting.



TOWN OF GOLDEN BEACH

One Golden Beach Drive
Golden Beach, FL 33160

Official Minutes for the January 23, 2018 Special Town Council Meeting called for 7:00 P.M.

A. MEETING CALLED TO ORDER

Mayor Singer called the meeting to order at 7:07 p.m.

B. ROLL CALL

Councilmember's Present: Mayor Glenn Singer, Vice Mayor Judy Lusskin, Councilmember Jaime Mendal, Councilmember Kenneth Bernstein

Councilmember's Not Present: Councilmember Amy Isackson-Rojas

Staff Present: Town Manager Alexander Diaz, Town Clerk Lissette Perez, Town Attorney Steve Helfman, Police Chief Rudy Herbello, Town Planner Michael Miller

*** Town Manager stated for the record that Councilmember Rojas asked to be excused from the meeting as she is out of Town ***

C. PLEDGE OF ALLEGIANCE

Chief Herbello led the Pledge of Allegiance

D. PRESENTATIONS / TOWN PROCLAMATIONS

CERTIFICATE OF APPRECIATION TO 5K COMMITTEE MEMBERS
RECOGNITION OF EMPLOYEE OF THE YEAR – All Town Employees
RECOGNITION OF OFFICER OF THE YEAR – All Town Officers

E. MOTION TO SET THE AGENDA

ADDITIONS/ DELETIONS/ REMOVAL OF ITEMS FROM CONSENT
AGENDA/ AND CHANGES TO AGENDA

Councilmember Mendal asked to add the following discussion items:

- Pedestrian Gates
- CodeRed
- Hurricane Irma Reports

Town Manager advised that there was a change to the agenda in the discussion and direction to the Town Manager under Mayor Singer.

Consensus vote 4 Ayes, 0 Nays to set the agenda.

F. GOOD AND WELFARE

Donna Smith, 220 South Island Drive

Stated that she has always felt safe in Town, but as of lately feels that the police presence in Town is not what it used to be. The gate arm is always opening, even when she has been in a rental car. Recently knocked on the command post vehicle door and no one answered. Just wondering where the police are.

Mayor Michael Addicott, 155 Golden Beach Drive

Read a letter into the record concerning the health and safety hazards of allowing dogs on the Town's beaches.

G. MAYOR'S REPORT

Spoke on the guardhouse and beach pavilion projects.

Spoke on additional security throughout Town.

Security and safety is a concern and something that the Town is looking into.

Adding additional cameras and will be working to enhance security in Town.

Adding deterrents for speeders on A1A that will hopefully help with that issue.

Regarding dogs on the beach, stated that Mayor Addicott did have some valid points. However, the event that the Town did have was a big success and it was not at the beach pavilion area, it was just north of there on a resident's property. Hopefully can figure out a solution to Mayor Addicott's points.

H. COUNCIL COMMENTS

Councilmember Bernstein

Mentioned that he happened to stop by the New Year's event in Town and that it was a great event.

Thanked resident Donna Smith for her observations about the safety in Town and that it is an important issue to the Council.

Thinks that the lighting project with FPL should help with some of the safety issues as well as beautify the Town.

Vice Mayor Lusskin

Encouraged residents to leave their lights on at night outside of their homes as a deterrent to possible criminals.

Stated that the incident that took place in Town took place early in the evening, and it was a valiant effort put on by the Police Department. Wondering if at that moment when the incident occurred if the Town should not have considered a CodeRed phone call. Understands that this could create chaos, but it was so early in the evening that she does not know what the right answer is.

Also getting some phone calls about the pedestrian gates and whether or not to lock them or keep them open. Doesn't know what the answer is, but wanted to bring up that this is an ongoing issue for residents.

Also getting phone calls from residents in a certain area of Town that are having continual issues with internet and cable service from Atlantic broadband.

Councilmember Mendal

Stated that movie night was great. Thinks that we should have more of those. People really love it.

Stated that residents have two people residents have told him that they have gotten nails stuck in their tires due to the construction at the guardhouse.

The **Town Manager** stated that they have not started using nails yet, so it could not be coming from the work being done at the guardhouse.

Councilmember Mendal also stated that some residents who work regular business hours have inquired about Town Hall being open once or twice a month on extended or after regular business hours.

I. TOWN MANAGER REPORT

Stated that the Administration is still working with FEMA to get the Town's reimbursement from them.

The police gatehouse is moving along. Did approve the replacement of the roof and that will begin this week.

Beach pavilion is moving along. Gates around Town will be addressed during that item.

Public safety committee meeting is next Wednesday at 6 p.m. at Town Hall.

There will be a town forum on public safety on February 6th at 6 p.m., that is open to the public.

Do know that the residents are extremely concerned. When you do not see officers, it does not mean that they are not in Town. Sometimes staffing levels are not enough. To assist this the Town now has plain-clothes officers and plain cars in Town too. We do recommend that you call the substation if you need assistance, however if you have an emergency call 9-1-1. The difference between a 9-1-1 call response and a regular guardhouse call could be a 6-minute response time difference.

Vice Mayor Lusskin recommended that something be placed in the newsletter explaining the importance of calling 9-1-1 in an emergency.

Town Manager spoke on the CodeRed issue stating that we do not want a CodeRed message to go out that will put an officer's life in danger as well as the residents' life.

Also asked residents with alarm systems in their homes to please call the alarm companies, and register the Town substation first and then themselves.

Town Manager stated that the Town would be undertaking a review to enact a lighting ordinance that will be coming out in March. Also will be changing the code to call for certification/recertification of seawalls, allowing for a minimum of 5 feet and a maximum of 6 feet.

Also stated for the record that the dog event was held on private, not public property.

J. TOWN ATTORNEY REPORT

None

K. ORDINANCES – SECOND READING

None

L. ORDINANCES - FIRST READING

1. An Ordinance of the Town Council Amending the Town's Code Related to Rooftop Activities.

AN ORDINANCE OF THE TOWN OF GOLDEN BEACH, FLORIDA, AMENDING THE TOWN'S CODE OF ORDINANCES TO REVISE CHAPTER 66, "ZONING," BY AMENDING THE TITLE OF DIVISION 11 "ACCESSORY BUILDINGS: AND BY AMENDING SECTION 66-261 RELATED TO ROOFTOP ACTIVITIES; PROVIDING FOR SEVERABILITY; PROVIDING FOR CODIFICATION; PROVIDING FOR CONFLICTS; AND PROVIDING AN EFFECTIVE DATE.

Exhibit: Agenda Report No. 1
Ordinance No. 577.18

Sponsor: Town Administration

Recommendation: Motion to Approve Ordinance No. 577.18

A motion to approve was made by Vice Mayor Luskin, seconded by Councilmember Bernstein.

On roll call, the following vote ensued:

Mayor Singer	<u>Aye</u>
Vice Mayor Luskin	<u>Aye</u>
Councilmember Bernstein	<u>Aye</u>
Councilmember Isackson-Rojas	<u>Absent</u>
Councilmember Jaime Mendal	<u>Aye</u>

The motion passed.

Town Manager states that this cleans up the previous ordinance, codifying what the council agreed to at previous meetings.

Councilmember Mendal stated that he does have some objection to the passive leisure activities because he feels that they should be allowed to have spas on the rooftop, but has no objection to the other elements of it.

Town Manager stated that a Councilmember can put forth a motion to do an up and down vote on an amendment to the ordinance.

Mayor Singer asked if the ordinance states that residents can't have a spa on the rooftop at all.

Town Manager stated that it is stated in the ordinance that spas are not allowed.

Councilmember Mendal stated that he would like to allow the use of spas on the rooftop.

A motion to amend the ordinance was made by **Councilmember Mendal**, seconded by **Mayor Singer**.

Mayor Singer stated that to change the ordinance to allow for one water feature.

Town Manager stated that they will add language stating that a water feature will be allowed as approved by the BRAB. To reiterate, he stated that there will be an amendment to the ordinance directing staff to bring back at second reading language to allow the addition of one water feature subject to approval by the BRAB.

2. An Ordinance of the Town Council Amending the Town's Code Related to Community Design Standards.

AN ORDINANCE OF THE TOWN OF GOLDEN BEACH, FLORIDA, AMENDING THE TOWN'S CODE OF ORDINANCES RELATED TO COMMUNITY DESIGN STANDARDS; AMENDING SECTION 66-137 OF THE ZONING CODE RELATED TO ACCEPTABLE PAINT COLORS; PROVIDING FOR SEVERABILITY; PROVIDING FOR CODIFICATION; AND PROVIDING AN EFFECTIVE DATE.

Exhibit: Agenda Report No. 2
Ordinance No. 578.18

Sponsor: Town Administration

Recommendation: Motion to Approve Ordinance No. 578.18

A motion to approve was made by Councilmember Mendal, seconded by Councilmember Bernstein.

On roll call, the following vote ensued:

Mayor Singer	<u>Aye</u>
Vice Mayor Lusskin	<u>Aye</u>
Councilmember Bernstein	<u>Aye</u>
Councilmember Isackson-Rojas	<u>Absent</u>
Councilmember Jaime Mendal	<u>Aye</u>

The motion passed.

Town Manager stated that this item allows the staff to charge a fee for the paint permit.

M. QUASI JUDICIAL RESOLUTIONS

**** **Town Manager** stated that items #3 and #5 would be removed from the item. ****

3. A Resolution of the Town Council Approving A Variance Request for the Property Located at 407 Ocean Boulevard.

A RESOLUTION OF THE TOWN OF GOLDEN BEACH, FLORIDA, AUTHORIZING AND APPROVING VARIANCE REQUESTS FOR THE PROPERTY LOCATED AT 407

OCEAN BOULEVARD, GOLDEN BEACH, FLORIDA 33160

1). TO PERMIT AN ARCHITECTURAL WINDOW ELEMENT FEATURE WHICH IS NOT LISTED IN THE CODE TO PROJECT INTO THE SIDE YARD SETBACK FROM THE SECOND FLOOR.

2 TO PERMIT AN EXEMPTION FROM THE TOWN'S CODE REQUIREMENT TO INCREASE THE SIDE SETBACKS ALONG TWO THIRDS OF THE LENGTH OF THE SECOND STORY BY ONE FOOT FOR EACH ONE FOOT OF BUILDING HEIGHT ABOVE THE FIRST 18 FEET.

~~3. TO PERMIT A SMALL JAGUZZI AND COLD WATER PLUNGE POOL AREA TO BE LOCATED ON THE HIGHEST ROOF DECK WHICH IS NOT ALLOWED BY THE CODE.~~

4. 3. TO PERMIT A FRONT PROPERTY DRIVEWAY GATE TO BE LOCATED LESS THAN 18 FEET FROM A1A/ OCEAN BOULEVARD.

~~5. TO PERMIT A ROOFTOP ELEVATOR AND VESTIBULE OVERRIDE NOT TO EXCEED 110 SQUARE FEET.~~

6. 4. TO ALLOW THE GARAGE/GUEST HOUSE STRUCTURE TO BE EXEMPT FROM THE REQUIRED SIDE SETBACK REQUIREMENT AFTER 18 FEET IN HEIGHT.

~~7. 5. TO PERMIT THE GARAGE/GUEST HOUSE SIDE SETBACK TO BE AT 7.5 FEET INSTEAD OF 10 FEET OUTLINED IN THE CODE.~~

Exhibit: Agenda Report No. 3
Resolution No. 2536.18

Sponsor: Town Administration

Recommendation: Motion to Approve Resolution No. 2536.18

A motion to approve was made by Vice Mayor Luskin, seconded by Councilmember Mendal.

On roll call, the following vote ensued:

Mayor Singer	<u>Aye</u>
Vice Mayor Luskin	<u>Aye</u>
Councilmember Bernstein	<u>Aye</u>
Councilmember Isackson-Rojas	<u>Absent</u>
Councilmember Jaime Mendal	<u>Aye</u>

The motion passed.

Michael Miller Town Planner spoke on the item.

Mr. Paul Fischman, 8425 Biscayne Blvd. Miami, Florida gave a presentation of the design elements of the application.

Mayor Singer asked that they look at the variance request by request and vote on each individually requested element.

Mayor Singer inquired about the size of the projection of the eyebrow.

Town Manager Diaz stated that staff interprets this to be a decorative item and therefore unnecessary.

Councilmember Mendal asked Michael Miller if he considers this an eyebrow.

Mr. Ralph Choeff stated that in this case it's a ten foot and only projecting for 12 inches to create an illusion and break up the straight plane. This makes the architecture better and it's not a habitable space or a balcony.

Council requested to have a roll call vote on each requested item separately. The roll call vote was follows:

1. Roll Call Vote 4 Ayes, 0 Nays.
2. Roll Call Vote 4 Ayes, 0 Nays.
3. Roll Call Vote 4 Ayes, 0 Nays (Formerly #4)
4. Roll Call Vote 4 Ayes, 0 Nays (Formerly #6)
5. Request was made to withdraw (Formerly #7)

Town Manager spoke on item #3 stating that the variance will allow for a 5-foot encroachment on the rear setback. Because we know where the neighbor to the north is and how far south the other neighbor is, it would be punitive.

Town Manager stated that on Item #4 they are agreeing to not require a step-in for the garage/guest house.

Town Manager spoke on the issue of the first floor elevation that was not presented with this variance request. Recommended that staff work with the applicant to come to an agreement on behalf of the council and if the applicant absolutely cannot live with it, then they will come to the board.

N. CONSENT AGENDA

4. Official Minutes of the November 21st, 2017 Regular Town Council Meeting
5. A Resolution of the Town Council Approving the Contribution of \$2,000 to Best Buddies on Behalf of the Golden Beach 5K Race Committee.

A RESOLUTION OF THE TOWN COUNCIL OF THE TOWN OF GOLDEN BEACH, FLORIDA, AUTHORIZING AND APPROVING THE PAYMENT OF \$2,000.00 TO BEST BUDDIES INTERNATIONAL ON BEHALF OF THE TOWN OF GOLDEN BEACH 5K RACE COMMITTEE; PROVIDING

FOR IMPLEMENTATION; AND PROVIDING AN EFFECTIVE DATE.

Exhibit: Agenda Report No. 5
Resolution No. 2537.18

Sponsor: Town Administration

Recommendation: Motion to Approve Resolution No. 2537.18

Consensus vote 3 Ayes, 0 Nays. Items N4 – N5 pass.

*** *Councilmember Mendal stepped out during the vote.* ***

O. TOWN RESOLUTIONS

- 6. A Resolution of the Town Council Authorizing a Change Order to the Contract with Bejar Construction, Inc.

A RESOLUTION OF THE TOWN OF GOLDEN BEACH, FLORIDA, AUTHORIZING AND APPROVING A CHANGE ORDER TO THE CONTRACT BETWEEN THE TOWN OF GOLDEN BEACH AND BEJAR CONSTRUCTION, INC.; PROVIDING FOR IMPLEMENTATION; AND PROVIDING FOR AN EFFECTIVE DATE.

Exhibit: Agenda Report No. 6
Resolution No. 2538.18

Sponsor: Town Administration

Recommendation: Motion to Approve Resolution No. 2538.18

A motion to approve was made by Vice Mayor Lusskin, seconded by Councilmember Bernstein.

On roll call, the following vote ensued:

Mayor Singer	<u>Aye</u>
Vice Mayor Lusskin	<u>Aye</u>
Councilmember Bernstein	<u>Aye</u>
Councilmember Isackson-Rojas	<u>Absent</u>
Councilmember Jaime Mendal	<u>Aye</u>

The motion passed.

Town Manager stated that this item is change order #3. Addresses all conduit for cameras, lights, electrical outlets, and transformer switch box in the west lot. Town Manager mentioned that this project does not include the fountains or the strand that will be another project. Also we ripped out the bathroom in the guardhouse that was not going to be ripped out originally, but should be able to get it back in there for the

\$16,000 which is what is left in the budget for the project. Stated that if any of the wood arches have wood rot or termites we might need to replace them

Vice Mayor Lusskin inquired about some of the change orders asking if they are due to termite damage.

Town Manager restated that that is not what change order #3 is about.

Councilmember Mendal asked if the bathroom would cost \$16,000 to be reinstalled. And asked if the new power and outlets will solve the gate arm issues.

Town Manager explained that the \$16,000 is the balance left in the project budget and is not how much the bathroom will cost alone, and the gate arms are not related to this and will discuss more in item #8.

After the vote, the **Town Manager** gave an update on the beach budget. There are no change orders that have been approved yet. There is a possible change order coming because we originally designed the beach with only 10 piles we're now putting in 29 piles so there is about \$19,000 piling work that is still underneath the budget. He also stated that the Mayor and him approved the under siding of the men's and women's bathroom – that's about \$11,000. **Town Manager** mentioned that what will come to the Council if it is more than \$25,000 is the painting, sand blasting, and replacing of the terrazzo floor. Still within budget for the Beach Pavilion project.

7. A Resolution of the Town Council Authorizing the Use of LETF Monies to Purchase New CCTV Cameras.

A RESOLUTION OF THE TOWN COUNCIL OF THE TOWN OF GOLDEN BEACH, FLORIDA, AUTHORIZING THE USE OF FORFEITED ASSETS FOR THE PURCHASE OF NEW DIGITAL CAMERAS FOR OUR CLOSED CIRCUIT TELEVISION (CCTV) SECURITY CAMERA SYSTEM AND BREAKAWAY ARMS TO BE USED BY THE TOWN'S POLICE DEPARTMENT; PROVIDING FOR IMPLEMENTATION; PROVIDING FOR AN EFFECTIVE DATE.

Exhibit: Agenda Report No. 7
Resolution No. 2539.18

Sponsor: Town Administration

Recommendation: Motion to Approve Resolution No. 2539.18

A motion to approve was made by Vice Mayor Lusskin, seconded by Councilmember Mendal.

On roll call, the following vote ensued:

Mayor Singer	<u>Aye</u>
Vice Mayor Lusskin	<u>Aye</u>
Councilmember Bernstein	<u>Aye</u>

Councilmember Isackson-Rojas Absent
Councilmember Jaime Mendal Aye

The motion passed.

Vice Mayor Luskin asked what a breakaway arm is.

Town Manager stated that a break away arm allows the gate arm to be more flexible and not break every time someone hits it.

Town Manager stated that the majority of this item is due to an analog CCTV system the Town installed 9 years ago. We have since gone digital with our system. We are now installing new digital cameras and adding new cameras in the gatehouse, two cameras in Tweddle Park, one by the roll up in the back where we store most of our expensive items, behind Town Hall, as well as replaces all the analog cameras throughout Town. This item does not include new cameras for the streets. That is another item that will be brought to the Council in April.

Mayor Singer stated that this is being paid for with LETF money.

Town Manager reminded the Council that we are using LETF dollars and we currently have over \$550,000 which still leaves us with about \$400,000 in LETF monies.

8. A Resolution of the Town Council Authorizing a Street Lighting Agreement with FPL.

A RESOLUTION OF THE TOWN COUNCIL OF THE TOWN OF GOLDEN BEACH, FLORIDA APPROVING A STREET LIGHTING AGREEMENT WITH FLORIDA POWER AND LIGHT COMPANY; PROVIDING FOR AUTHORIZATION; PROVIDING FOR IMPLEMENTATION; AND PROVIDING FOR AN EFFECTIVE DATE.

Exhibit: Agenda Report No. 8
Resolution No. 2540.18

Sponsor: Town Administration

Recommendation: Motion to Approve Resolution No. 2540.18

A motion to approve was made by Vice Mayor Luskin, seconded by Councilmember Mendal.

On roll call, the following vote ensued:

Mayor Singer Aye
Vice Mayor Luskin Aye
Councilmember Bernstein Aye
Councilmember Isackson-Rojas Absent
Councilmember Jaime Mendal Aye

The motion passed.

*****Town Manager** spoke on this item and the next two items at the same time.***

Town Manager stated that what was originally a \$3 million lighting project has gone down in price now that the community is going with FPL, and allowing FPL to come in and replace all the current lights with LED lights. There is a disadvantage and an advantage to an LED light. Many residents may not like the glow of an LED light because it is a white glow and the Town currently has an orange glow, but there are three levels of intensity of the white glow and we are going with the lowest one, which means a warmer white glow, but it is still a white glow. We currently have 120 lights in Town, and we are adding 60 new lights. Right now, we have our lights placed at random, on Golden Beach Drive they will be positioned diagonal from each other with equal distance. Most islands are getting six additional lights; all parks will also have lights, which they do not have now. FPL allows us to only pay for three things upfront and finance the rest of the project. What we are paying upfront for is the book value to our lights, the removal of all the poles, all the new conduits, wiring to the 60 new lights, and moving the lights from behind the sidewalk into the middle of the green way.

Town Manager reminded the Council that we received \$100,000 dollars from the State of Florida for this project, so we will be out of pocket very little upfront. We will be financing the value of this new system on a moving forward basis. We will go from what we are currently paying which is \$2,300 dollars a month for street lighting to \$5,500. Keep in mind that we are adding 60 new lights, financing 180 posts, heads, blubs, and including ongoing maintenance. This is a no brainer. We will get a lot of push back because many of our residents will not like the white glow, or the fixtures that we choose but we had a very limited number of fixtures to choose from. We are hoping to have all the lights installed by the end of this year.

Councilmember Bernstein asked if the Town has done any type of light study.

Town Manager stated that the Town has done two lighting studies. Four years ago, the Town hired Bailey Engineering to do a photometric reading of the Town. Based on the readings it was decided whether the lights were going to be ten feet apart or thirty feet apart because of the intensity of the white glow. The lights will be aiming towards the streets, not the homes.

Councilmember Bernstein asked if in the photometric study has there been a comparison to what it is to what it is going to be.

Town Manager stated that no and it would not make a difference because with this tariff system with FPL these are the only options available to the Town.

Councilmember Bernstein stated that his concern is that the Town does not end up looking like Disney World.

Vice Mayor Lusskin asked about the current lights.

Town Manager stated that when you add a white light it will be very visible, it will also look wider and that all the current lights are being replaced with the white lights.

Councilmember Mendal asked if one of the new lights will be placed by the dog park because it is dark currently.

Town Manager stated that we ordered four solar powered LED lights from Home Depot and they should have already been installed. The Police Chief will follow up on that.

Councilmember Mendal stated one final thing is to be very cognizant and be aware of how bright some areas are going to be.

9. A Resolution of the Town Council Authorizing an LED Lighting Agreement with FPL for \$16,300.00.

A RESOLUTION OF THE TOWN COUNCIL OF THE TOWN OF GOLDEN BEACH, FLORIDA APPROVING AN LED LIGHTING AGREEMENT WITH FLORIDA POWER AND LIGHT COMPANY IN AN AMOUNT NOT TO EXCEED \$16,300.00; PROVIDING FOR AUTHORIZATION; PROVIDING FOR IMPLEMENTATION; AND PROVIDING FOR AN EFFECTIVE DATE.

Exhibit: Agenda Report No. 9
Resolution No. 2541.18

Sponsor: Town Administration

Recommendation: Motion to Approve Resolution No. 2541.18

A motion to approve was made by Vice Mayor Luskin, seconded by Councilmember Mendal.

On roll call, the following vote ensued:

Mayor Singer	<u>Aye</u>
Vice Mayor Luskin	<u>Aye</u>
Councilmember Bernstein	<u>Aye</u>
Councilmember Isackson-Rojas	<u>Absent</u>
Councilmember Jaime Mendal	<u>Aye</u>

The motion passed.

10. A Resolution of the Town Council Authorizing an LED Lighting Agreement with FPL for \$68,481.00.

A RESOLUTION OF THE TOWN COUNCIL OF THE TOWN OF GOLDEN BEACH, FLORIDA APPROVING AN LED LIGHTING AGREEMENT WITH FLORIDA POWER AND LIGHT COMPANY IN AN AMOUNT NOT TO EXCEED \$68,481.00; PROVIDING FOR AUTHORIZATION; PROVIDING FOR IMPLEMENTATION; AND PROVIDING FOR AN EFFECTIVE DATE.

Exhibit: Agenda Report No. 10
Resolution No. 2542.18

Sponsor: Town Administration

Recommendation: Motion to Approve Resolution No. 2542.18

A motion to approve was made by Vice Mayor Lusskin, seconded by Councilmember Mendal.

On roll call, the following vote ensued:

Mayor Singer	<u>Aye</u>
Vice Mayor Lusskin	<u>Aye</u>
Councilmember Bernstein	<u>Aye</u>
Councilmember Isackson-Rojas	<u>Absent</u>
Councilmember Jaime Mendal	<u>Aye</u>

The motion passed.

Town Manager stated that for the record there was a cover memo that will govern the future expenditures related to this project, giving him spending authority.

P. DISCUSSION & DIRECTION TO TOWN MANAGER

Mayor Glenn Singer:

- Possibility of allowing business activities at beach pavilion for food and bike sharing program

Mayor Singer stated that Town code currently prohibits business activities in Town. Mentioned that the Town revised the code to allow enterprise activities at the beach for payment by residents. Also stated that there is a bike-sharing program that people can pay to essentially rent a bike. The program that's available to our Town does not work for us, but the program on south beach would. Revising the code can give us the ability and flexibility to offer some of these options.

Vice Mayor Lusskin asked how this would work with the charter prohibiting this activity.

Town Manager stated that this ordinance would change that. It would allow it so long as it is a government-sponsored event.

- Possibility of selling the boat dock lot and Town Hall lot to be voted on in the August primary election

Mayor Singer stated that the Town is in the process of looking to construct a civic center, Town Hall, and a fire station on A1A. Based on the survey a high number of the residents would love to have a gym, and a civic center in Town Hall where residents can rent it. The

estimated costs we're looking at could be as much as 10 million dollars or higher. We have different ways to raise the funds or absorb some of the costs. Two other possibilities would be to sell the two lots the Town owns one being the marine boat dock on Center Island Drive which is about a 100 foot lot if we were to sell it could go for about 6 million dollars. When the Mayor first thought of the idea, he thought it was a great idea but after going out there and looking at it he realized that, it is a very special lot with a lot of history to it. The more he thought about it the more he realized that he really did not want to sell the lot. Then the Manager thought of a great idea of keeping the Town Hall around the same current area it is in and building the civic center where the Boat Dock is.

Town Manager stated that this would drive the project budget up because it now becomes two separate projects

Mayor Singer stated that he would be against selling it to a resident and building a home but would not be against keeping it within the Town and making it a community center.

Councilmember Bernstein mentioned that the surrounding residents might be against having a civic center where all of the Residents would be coming to right next door to them.

Mayor Singer stated the other option would be to sell the area behind Town Hall where the maintenance department is. Also that if we put Town Hall on A1A that land where it currently is could be sold and could fetch about 2 million dollars.

Councilmember Mendal mentioned that from his understanding we do not need a referendum for that.

Town Manager stated that no, we do not but there is a lot of legal work that will go into that. The attorneys already began looking in to it and that he will also tell the attorneys to begin looking into referendum language and possible referendum questioning for selling the lot or financing a bond for the civic center, then ask the residents if they would vote for on a new G.O. Bond for the purposes of building a Civic Center. Stated for the record that this would go before the Town as a General Obligation Bond question at the August primary election.

Vice Mayor Judy Lusskin:
None Requested

Councilmember Kenneth Bernstein:
None Requested

Councilmember Amy Isackson-Rojas:
None Requested

Councilmember Jaime Mendal:

- Pedestrian Gates

Stated that he is getting many complaints about the locking of the pedestrian gates and the consistency of locking them. Stated that there are so many ways around those gates that he does not see the point of locking them.

Town Manager stated that the Town just signed a contract to put in new gates. They will all be contiguous.

Councilmember Mendal feels that a greater deterrent would be having cameras on the actual pedestrian gates.

Town Manager posed the questions should the Town have gates, what time to lock them, and should they have locks.

Town Mayor stated that the gates should be locked at 8:00 P.M.

Councilmember Mendal argued that that time is still too early.

Town Mayor determined the gate closing time as 10 p.m. to 6 a.m. all pedestrian gates will be locked during this time.

- Code Red - Asked about issuing them for emergency situations

Town Manager stated that we will not act irresponsible out of havoc, aggravation, fear or concern. As the Town's chief executive officer, he is tasked with making those tough decisions and will not exercise that duty in a reckless manner. Respectfully understands his concerns, but does not want to overuse the system. If Code Red is misused people become desensitized to it.

Councilmember Mendal stated that they already overuse it. Also that it is being used for traffic news.

Town Manager stated that when there is a road closure for longer than four hours and fatalities that calls for a Code Red.

Councilmember Mendal posed the question that the Town has used Code Red to announce Town events.

Town Manager Stated that in this Council back in 2008 when Code Red was purchased that Council instructed this Administration to use Code Red for Town events.

Councilmember Mendal asked if there was a written protocol to the severity of a situation that would lead to the issuance of a Code Red. **Town Manager** stated there is not, it is absolutely at his discretion. Also stated that the Town would have to come up with thousands of

scenarios to decide the severity of a situation. He also called surrounding City Manager's offices and their protocol to exercise CodeRed is always at the discretion of the Chief Administrator or strong Mayors discretion. In the Chief Administrators absence it goes to the Chief of Police with the consultation of the Town Clerk.

Mayor Singer agreed with the Town Manager that you do not want to start pre-chaos and that he has used his discrepancy on when to use Code Red and when not to.

Vice Mayor Lusskin stated she understand that there are pros and cons to using Code Red in a situation like the robbery that occurred. Also suggested that we have a community watch to keep watch.

Town Manager stated that during the frustration period we do send out information to our elected officials so they can be prepared for when the influx of calls come out. It is also part of our extended communication program that our elected officials serve as conduits to each concern to disseminate facts to end rumors. Manager strongly suggests residents call the Gatehouse when they need information about anything or they can call him.

Town Manager Alexander Diaz:
None Requested

Town Manager asked that the Councilmembers come meet with him individually to discuss amenities for North and Singer Park.

Town Manager stated that both Mayor Singer and Councilmember Mendal will be traveling with him on official Town business to Dade Days in Tallahassee for possible funding for a new Civic Center and specifically \$500,000 for a new pump station on Center Island. Also reminded residents that the following Wednesday there will be a public safety meeting chaired by Chief Herbello, and the Wednesday following that there will be a community workshop on public safety. The Town Manager reminded the Council of the next Regular Town Council Meeting scheduled for February 20.

Q. ADJOURNMENT:

A motion to adjourn the Council Meeting was made by Vice Mayor Lusskin, seconded by Councilmember Mendal.

Consensus vote 4 Ayes 0 Nays. Motion passes.

The meeting adjourned at 10:06 p.m.

Respectfully submitted,

Lissette Perez
Lissette Perez
Town Clerk



TOWN OF GOLDEN BEACH

One Golden Beach Drive
Golden Beach, FL 33160

MEMORANDUM

Date: February 20, 2018

To: Honorable Mayor Glenn Singer &
Town Council Members

From: Alexander Diaz,
Town Manger

Subject: Resolution No. 2543.18 – Creating a Retirement Health
Savings Program (RHSP) for Employees with ICMA-RC

Item Number:

4

Recommendation:

It is recommended that the Town Council adopt the attached Resolution No. 2543.18 as presented.

Background:

This is a new benefit program being offered to our employees. With the approval of the new collective bargaining agreement on August 22, 2017, a Retirement Health Savings program was agreed to. Given that the International City Management Association Retirement Corporation (ICMA-RC) is the Town's current provider for the 401(k) and the 457 programs, having them also manage the new RHSP keeps most of our offerings with a single administrator.

The agreement attached is needed to implement the new RHSP.

Fiscal Impact:

Employees are allowed to contribute up to the maximum allowable by the Internal Revenue Service.

The Town is to match dollar-for-dollar up to an annual maximum of \$500 per participating employee.

TOWN OF GOLDEN BEACH, FLORIDA

RESOLUTION NO. 2543.18

A RESOLUTION OF THE TOWN OF GOLDEN BEACH, FLORIDA, ESTABLISHING A RETIREMENT HEALTH SAVINGS PROGRAM FOR EMPLOYEES TO ASSIST WITH MEDICAL EXPENSES UPON RETIREMENT; AUTHORIZING MATCH FUNDING AND THE USE OF LEAVE BENEFITS; AUTHORIZING TOWN OFFICIALS TO TAKE ALL ACTIONS NECESSARY TO OFFER A RETIREMENT HEALTH SAVINGS PROGRAM; AUTHORIZING THE EXPENDITURE OF BUDGETED FUNDS; AND PROVIDING FOR AN EFFECTIVE DATE.

WHEREAS, the Town maintains a group health plan for both its active and retired employees and their eligible dependents; and

WHEREAS, the Town has determined that the establishment of a retiree health saving program (the "Program") for employees serves the interests of the Town by enabling it to provide reasonable security regarding such employees' health needs during retirement, and by assisting in the attraction and retention of competent personnel; and

WHEREAS, the Town has determined that the establishment of the Program for employees serves the above objectives; and

WHEREAS, the Town has determined that it is in its best interests to establish a Program for all employees on the same terms as agreed to by the Town and the Florida State Lodge, Fraternal Order of Police, Inc. (the "Union") in the ratified 2017 - 2020 collective bargaining agreement.

NOW, THEREFORE, BE IT RESOLVED BY THE TOWN COUNCIL OF THE TOWN OF GOLDEN BEACH, FLORIDA:

Section 1. Recitals Adopted. Each of the recitals stated above is hereby adopted and confirmed.

Section 2. Establishment of RHS Program. The Town hereby adopts the Program for its employees in the form of the ICMA Retirement Corporation's VantageCare Retirement Health Savings Program through the Town's integral part trust ("Trust") and welfare benefits plan (the "Plan"). The assets of the Plan shall be held in trust, with the Town serving as trustee for the exclusive benefit of Plan participants, their survivors and their beneficiaries, and the assets of the Plan shall not be diverted to any other purpose prior to the satisfaction of all liabilities of the Plan.

Section 3. Authorization to Contribute Matching Funds and Permit the Use of Leave Benefits. The Town shall match dollar-for-dollar employee contributions up to five-hundred dollars (\$500.00) annually. Each eligible employee shall also be allowed to use vacation leave for contributions. In the last year of Town employment, employees are permitted to use sick leave to contribute; however, this usage will decrease the 750 hour sick leave maximum at retirement/separation.

Section 4. Authorization of Town Officials; Implementation. The Town Mayor and Manager are authorized to take all action necessary to implement this Resolution and establish the Plan under these terms and conditions, and to forward all necessary documents as may be required to establish the benefit and execute any required agreements, trusts or documents.

Section 5. Authorization for Fund Expenditure. The Town Mayor and Manager are authorized to expend budgeted funds to implement the terms and conditions of this Resolution.

Section 6. Conflict. All resolutions or parts of resolutions in conflict herewith are repealed to the extent of such conflict.

Section 7. Severability. Should any sentence, section, clause, part, or provision of this Resolution be declared by a court of competent jurisdiction to be invalid, the same shall not affect the validity of this Resolution as a whole, or any part thereof, other than the part declared invalid.

Section 8. Effective Date. This Resolution shall be effective immediately upon adoption.

The Motion to adopt the foregoing Resolution was offered by _____, seconded by _____, and on roll call the following vote ensued:

Mayor Glenn Singer	_____
Vice Mayor Judy Lusskin	_____
Councilmember Kenneth Bernstein	_____
Councilmember Amy Isackson-Rojas	_____
Councilmember Jaime Mendal	_____

PASSED AND ADOPTED by the Town Council of the Town of Golden Beach, Florida this 20th day of February, 2018.

MAYOR GLENN SINGER

ATTEST:

LISSETTE PEREZ
TOWN CLERK

APPROVED AS TO FORM
AND LEGAL SUFFICIENCY:

STEPHEN J. HELFMAN
TOWN ATTORNEY



TOWN OF GOLDEN BEACH

One Golden Beach Drive
Golden Beach, FL 33160

MEMORANDUM

Date: February 20, 2018

To: Honorable Mayor Glenn Singer &
Town Council Members

From: Alexander Diaz,
Town Manger

Subject: Resolution No. 2544.18 – Approving Enhancements to the
Town's Parks

Item Number:

5

Recommendation:

It is recommended that the Town Council adopt the attached Resolution No. 2544.18 as presented.

Background:

The last eighteen (18) months we have explored a variety of options to enhance the amenities offered on the north end of Town, specifically for our younger residents. After a series of discussions, designs and compromises I am recommending the following:

- That we add an amenity in Singer Park (as described in the attachment)
- That we add two swings in North Park (outside of the recreation field) (attached)
- Enhance amenities to the Tot-Lot in Tweddle Park (as described in the attachment)
- Enhance amenities in the Fitness Area in Tweddle Park (Items to be added attached)
- Install new shade structure(s) over the Tot-Lot play area in Tweddle Park

I am asking for your acceptance and approval to achieve the scope of work listed above. We will maximize our spending ability and secure the most amenities possible by working with the selected vendor(s).

Fiscal Impact:

\$90,000.00 as budgeted in the Recreation Budget.

TOWN OF GOLDEN BEACH, FLORIDA

RESOLUTION NO. 2544.18

A RESOLUTION OF THE TOWN COUNCIL OF THE TOWN OF GOLDEN BEACH, FLORIDA, ACCEPTING THE TOWN MANAGER'S RECOMMENDATIONS PERTAINING TO THE TOWN'S PARKS; PROVIDING FOR AUTHORIZATION FOR THE TOWN MANAGER TO IMPLEMENT THE PROGRAM IN THE MANNER DESCRIBED; AND PROVIDING FOR AN EFFECTIVE DATE.

WHEREAS, the Town Council desires to enhance the use and enjoyment of its parks with the purchase and installation of new recreational equipment for use by youth residing within the Town; and

WHEREAS, the Town Council has determined that the recommendations submitted by the Town Manager as described and attached hereto as Exhibits "A, B & C," are acceptable and the enhancements will well serve the needs of the Town residents and in particular the children within the Town.

NOW, THEREFORE, BE IT RESOLVED BY THE TOWN COUNCIL OF THE TOWN OF GOLDEN BEACH, FLORIDA, AS FOLLOWS:

Section 1. Recitals Adopted. Each of the above stated recitals are hereby adopted and confirmed.

Section 2. Purchase Authorized and Approved. The recommendations attached as Exhibits "A, B & C" are hereby approved and ratified.

Section 3. Implementation. The Town Mayor and Town Manager are hereby directed to take all steps necessary to implement this Resolution and the purchase of the equipment.

Section 4. Effective Date. This Resolution shall be effective immediately upon adoption.

The Motion to adopt the foregoing Resolution was offered by _____, seconded by _____ and on roll call the following vote ensued:

Mayor Glenn Singer	_____
Vice Mayor Judy Lusskin	_____
Councilmember Amy Isackson-Rojas	_____
Councilmember Kenneth Bernstein	_____
Councilmember Jaime Mendal	_____

PASSED AND ADOPTED by the Town Council of the Town of Golden Beach, Florida, this 20th day February, 2018.

MAYOR GLENN SINGER

ATTEST:

LISSETTE PEREZ
TOWN CLERK

APPROVED AS TO FORM
AND LEGAL SUFFICIENCY:

STEPHEN J. HELFMAN
TOWN ATTORNEY

EXHIBIT A



PlayPower LT Farmington, Inc.
878 E. US Hwy 60
Monett, MO 65708
1-800-325-8828

QUOTE: R0321181008

Project: LP844_43117124500_02

Bill To:

Michael Gidden
Town of Golden Beach
North Park
Golden Beach, FL 33160

Project Name & Location:

Town of Golden Beach North
Park Rev 1
Attn: Michael Gidden
Golden Beach, FL 33160

Prepared by:

Playworx Playsets, LLC
Jennifer Garcia
407-912-1693
jennifergarcia@playworx.com

Ship To Address:

Michael Gidden
Town of Golden Beach
North Park
Golden Beach, FL 33160

End User:

Michael Gidden
Town of Golden Beach
North Park
Golden Beach, FL 33160

Quote Number: R0321181008
Quote Date: 1/23/2018
Valid For: 30 Days From Quote Date

Swings PlayArea_1_1

Product line: Traditional Play
Age group: 2-12

Global defaults

Inclusive Seat Clr	Green
Kid Builder Post Color	SAND
Tot Swing Seat Color	Green
Us/Csa Labels For Swings	US Swing Label

Components

Part Number	Description	Qty	Weight	Volume	Unit Price	Total
100001231	Kid Timberâ„¢ Panel, 1830 mm (6') (Black)	17	29.00	3.00	66.00	1,122.00
100001232	Kid Timberâ„¢ Panel, 610 mm (2') (Black)	1	12.00	1.00	64.00	64.00
200200414	2440 mm (8') Arch Swing Frame (frame only) one seat per bay, any seat type	1	389.00	10.00	2,001.00	2,001.00
200200415	2440 mm (8') Arch Swing Add-on Frame (frame only) one seat per bay, any seat type	1	228.00	6.00	1,181.00	1,181.00
200202836	ASSY TOT SEAT F/8' SWING W/CHAIN	1	21.00	1.00	179.00	179.00
200203423	Generation Swing Inclusive Seat Clr: GREEN	1	30.00	0.00	795.00	795.00

Sphere PlayArea_2_1

Product line: Traditional Play

Age group: 5-12

Global defaults

Wobble Sphere Plastic Color

GRAY

Wobble Sphere Post Color

SAND

Components

Part Number	Description	Qty	Weight	Volume	Unit Price	Total
100001231	Kid Timberâ„¢ Panel, 1830 mm (6') (Black)	14	29.00	3.00	66.00	924.00
100001232	Kid Timberâ„¢ Panel, 610 mm (2') (Black)	2	12.00	1.00	64.00	128.00
200203198	Wobble Sphere	1	175.00	50.00	1,889.00	1,889.00

Additional Items

Part Number	Description	Qty	Weight	Volume	Unit Price	Total
200111492	Label, Identification stamped w/rivets	1	0.00	0.00	0.00	0.00
200111492	Label, Identification stamped w/rivets	1	0.00	0.00	0.00	0.00
200305597	CRATE,LARGE.14' L X 54.5" H	1	385.00	0.00	0.00	0.00

Totals:

Equipment Weight:	2,163.00 lbs
Equipment Volume:	163.00 ft ³
Equipment List:	\$8,283.00
Discount Amount:	-\$1,656.60
Products Subtotal:	\$6,626.40
Products by Other:	\$10,000.00
Rubber mulch to cover both areas.	
Installation:	\$3,000.00
Estimated Sales Tax*:	\$0.00
Freight:	\$1,344.09
Grand Total:	\$20,970.49

Make Purchase Orders Out To:

PlayPower LT Farmington, Inc.

Remit Purchase Orders To:

PlayPower LT Farmington, Inc.

Attention: Sales Administration

878 E US Hwy 60

Monett, Missouri, USA 65708

1-800-325-8828

Make Checks Payable To:

PlayPower LT Farmington, Inc.

Remit Checks To:

PlayPower LT Farmington, Inc.

P.O. Box 204713

Dallas, TX 75320-4713

NOTE:

* Applicable sales taxes will be confirmed once order and any tax certificates are received

† Denotes drop ship item.

Unloading, storage, installation, surfacing and site work are not included unless specifically noted on quotation.

Not responsible for filter cloth, irrigation rerouting, grass damage, or checking for underground utilities.

If installation is quoted, it is assumed that the site has been prepared and that any grade slope in any direction does not exceed 2%. In the event that unexpected soil conditions, such as subsurface rock, are encountered during installation, additional costs to the customer will be applicable.

The acceptance signature below serves as authorization to order the items quoted and indicates acceptance of the prices listed. All terms are subject to credit approval.

COMMENTS:

This playground contains 15.96% recycled content
This playground qualifies for 1 LEED point(s)

This Quote shall not become a binding contract until signed and delivered by both Customer and PlayPower LT Farmington Inc ("PPLT"). Sales Representative is not authorized to sign this Quote on behalf of PPLT or Customer, and signed Quotes cannot be accepted from Sales Representative. To submit this offer, please sign below and forward a complete signed copy of this Quote directly to "PPLT Sales Administration" via fax (417)354-2273 or email outdoordes@LTCPS.com. Upon acceptance, PPLT will return a fully-signed copy of the Quote to Customer (with copy to Sales Representative) via fax or e mail.

THIS QUOTE IS LIMITED TO AND GOVERNED BY THE TERMS CONTAINED HEREIN. PPLT objects to any other terms proposed by Customer, in writing or otherwise, as material alterations, and all such proposed terms shall be void. Customer authorizes PPLT to ship the Equipment and agrees to pay PPLT the total amount specified. Shipping terms are FOB the place of shipment via common carrier designated by PPLT. Payment terms are Net-30 days from invoice date with approved credit and all charges are due and payable in full at PO Box 204713, Dallas, TX 75320-4713, unless notified otherwise by PPLT in writing. Customer agrees to pay all additional service charges for past due invoices. Customer must provide proper tax exemption certificates to PPLT, and shall promptly pay and discharge all otherwise applicable taxes, license fees, levies and other impositions on the Equipment at its own expense.

CUSTOMER HEREBY SUBMITS ITS OFFER TO PURCHASE THE EQUIPMENT ACCORDING TO THE TERMS STATED IN THIS QUOTE AND SUBJECT TO FINAL APPROVAL BY PPLT.

Submitted By	Printed Name and Title	Date
--------------	------------------------	------

THE FOREGOING QUOTE AND OFFER ARE HEREBY APPROVED AND ACCEPTED BY PLAYPOWER LT FARMINGTON INC.

By: _____ Date: _____

ADDITIONAL TERMS & CONDITIONS OF SALE

1. Use & Maintenance. Customer agrees to regularly inspect and maintain the Equipment, and to provide, inspect and maintain appropriate safety surfacing under and around the Equipment, in accordance with PPLT's product literature and the most current Consumer Product Safety Commission Handbook for Public Playground Safety.

2. Default, Remedies & Delinquency Charges. Customer's failure to pay any invoice when due, or its failure to otherwise comply with the terms of this Quote, shall constitute a default under all unsatisfied invoices ("Event of Default"). Upon an Event of Default, PPLT shall have all remedies available to it at law or equity, including, without limitation, all remedies afforded a secured creditor under the Uniform Commercial Code. Customer agrees to assist and cooperate with PPLT to accomplish its filing and enforcement of mechanic's or other liens with respect to the Equipment or its location or its repossession of the Equipment, and Customer expressly waives all rights to possess the Equipment after an Event of Default. All remedies are cumulative and not alternative, and no exercise by PPLT of a remedy will prohibit or waive the exercise of any other remedy. Customer shall pay all reasonable attorneys' fees plus any costs of collection incurred by PPLT in enforcing its rights hereunder. Subject to any limitations under law, Customer shall pay to PPLT as liquidated damages, and not as a penalty, an amount equal to 1.5% per month of any payment that is delinquent in such month and is not received by PPLT within ten (10) days after the date on which due.

3. Limitation of Warranty/ Indemnity. PPLT MAKES NO EQUIPMENT WARRANTIES EXCEPT FOR THOSE STANDARD WARRANTIES ISSUED WITH THE EQUIPMENT, WHICH ARE INCORPORATED HEREIN BY THIS REFERENCE. PPLT SPECIFICALLY DISCLAIMS ANY IMPLIED WARRANTY OF MERCHANTABILITY OR FITNESS FOR A PARTICULAR PURPOSE AND ANY LIABILITY FOR INCIDENTAL OR CONSEQUENTIAL DAMAGES. CUSTOMER AGREES TO DEFEND, INDEMNIFY AND SAVE PPLT HARMLESS FROM ALL CLAIMS OF ANY KIND FOR DAMAGES OF ANY KIND ARISING OUT OF CUSTOMER'S ALTERATION OF THE EQUIPMENT, ITS FAILURE TO MAINTAIN THE EQUIPMENT, ITS FAILURE TO PROPERLY SUPERVISE EQUIPMENT USE, OR ITS FAILURE TO

PROVIDE AND MAINTAIN APPROPRIATE TYPES AND DEPTHS OF SAFETY SURFACING BENEATH AND AROUND THE EQUIPMENT IN ACCORDANCE WITH PPLT'S INSTALLATION AND OWNER'S MANUALS AND THE MOST CURRENT CONSUMER PRODUCT SAFETY COMMISSION HANDBOOK FOR PUBLIC PLAYGROUND SAFETY.

4. Restrictions. Until all amounts due hereunder are paid in full, Customer shall not: (i) permit the Equipment to be levied upon or attached under any legal process; (ii) transfer title to the Equipment or any of Customer's rights therein; or (iii) remove or permit the removal of the Equipment to any location not specified in this Quote.

5. Purchase Money Security Interest. Customer hereby grants, pledges and assigns to PPLT, and PPLT hereby reserves a purchase money security interest in, the Equipment in order to secure the payment and performance in full of all of Customer's obligations hereunder. Customer agrees that PPLT may file one or more financing statements, in order to allow it to perfect, acquire and maintain a superior security interest in the Equipment.

6. Choice of Law and Jurisdiction. All agreements between Customer and PPLT shall be interpreted, and the parties' obligations shall be governed, by the laws of the State of Missouri without reference to its choice of law provisions. Customer hereby consents to the personal jurisdiction of the state and federal courts located in the city and county of St. Louis, Missouri.

7. Title; Risk of Loss; Insurance. PPLT Retains full title to all Equipment until full payment is received by PPLT. Customer assumes all risk of loss or destruction of or damage to the Equipment by reason of theft, fire, water, or any other cause, and the occurrence of any such casualty shall not relieve the Customer from its obligations hereunder and under any invoices. Until all amounts due hereunder are paid in full, Customer shall insure the Equipment against all such losses and casualties.

8. Waiver; Invalidity. PPLT may waive a default hereunder, or under any invoice or other agreement between Customer and PPLT, or cure such a default at Customer's expense, but shall have no obligation to do either. No waiver shall be deemed to have taken place unless it is in writing, signed by PPLT. Any one waiver shall not constitute a waiver of other defaults or the same kind of default at another time, or a forfeiture of any rights provided to PPLT hereunder or under any invoice. The invalidity of any portion of this Quote shall not affect the force and effect of the remaining valid portions hereof.

9. Entire Agreement; Amendment; Binding Nature. This fully-executed Quote, as supplemented by Change Orders and invoices containing exact amounts of estimates provided herein, constitutes the complete and exclusive agreement between the parties. A Change Order is a written instrument signed by the Customer and PPLT stating their agreement as to any amendment in the terms of this Quote. Customer acknowledges that Change Orders may result in delays and additional costs. The parties agree that all Change Orders shall include appropriate adjustments in price and time frames relating to any requested amendments. Upon full execution, this Quote shall be binding upon and inure to the benefit of the parties and their successors and assigns.

10. Counterparts; Electronic Transmission. This Quote, any invoice, and any other agreement between the parties, may be executed in counterparts, each of which shall constitute an original. The facsimile or other electronic transmission of any signed original document, and retransmission of any signed facsimile or other electronic transmission, shall be the same as the transmission of an original. At the request of either party, the parties will confirm facsimile or other electronically transmitted signatures by signing an original document.

General Notes:

Age Group

2-5yrs 5-12 yrs 12-17yrs 18+ yrs

- The Americans with Disabilities Act (ADA) may require that you make your park and/or playground accessible when viewed in its entirety. Please consult your legal counsel to determine if the ADA applies to you.
- For playground equipment to be considered accessible, accessible surfacing must be utilized in applicable areas.
- Although a particular playground design may not meet the proposed Access Board Regulations in regards to the appropriate number of ground level events, the actual playground may be in compliance when considering existing play components.
- All deck heights are measured from top of ground cover.
- Fall absorbing ground cover is required under and around all play equipment.
- The minimum recommended fall zone around the entire playstructure is shown. This zone is to be free of all tripping or collision hazards (i.e. roots, rocks, border material, etc.).
- All post lengths are identified by text showing the post lengths, i.e. 96 represents a 96 inch post.
- Not all equipment may be appropriate for all children. Supervision is required.

Child Capacity: 8

AGE GROUP: 2-12
 ELEVATED PLAY ACTIVITIES - TOTAL: 0
 ELEVATED PLAY ACTIVITIES ACCESSIBLE BY TRANSFER: 0 REQ'D 0
 ELEVATED PLAY ACTIVITIES ACCESSIBLE BY RAMP: 0 REQ'D 0
 GROUND LEVEL ACTIVITY TYPE: 1 REQ'D 0
 GROUND LEVEL QUANTITY: 2 REQ'D 0

AGE GROUP: 5-12
 ELEVATED PLAY ACTIVITIES - TOTAL: 0
 ELEVATED PLAY ACTIVITIES ACCESSIBLE BY TRANSFER: 0 REQ'D 0
 ELEVATED PLAY ACTIVITIES ACCESSIBLE BY RAMP: 0 REQ'D 0
 GROUND LEVEL ACTIVITY TYPE: 1 REQ'D 0
 GROUND LEVEL QUANTITY: 1 REQ'D 0

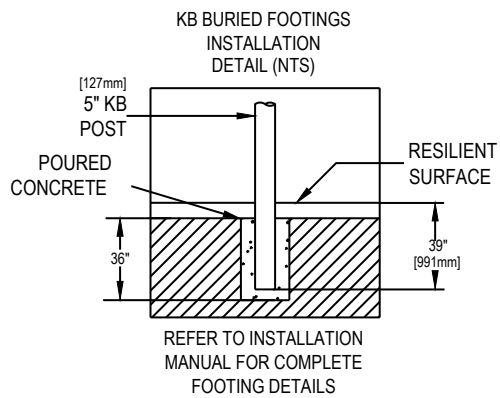
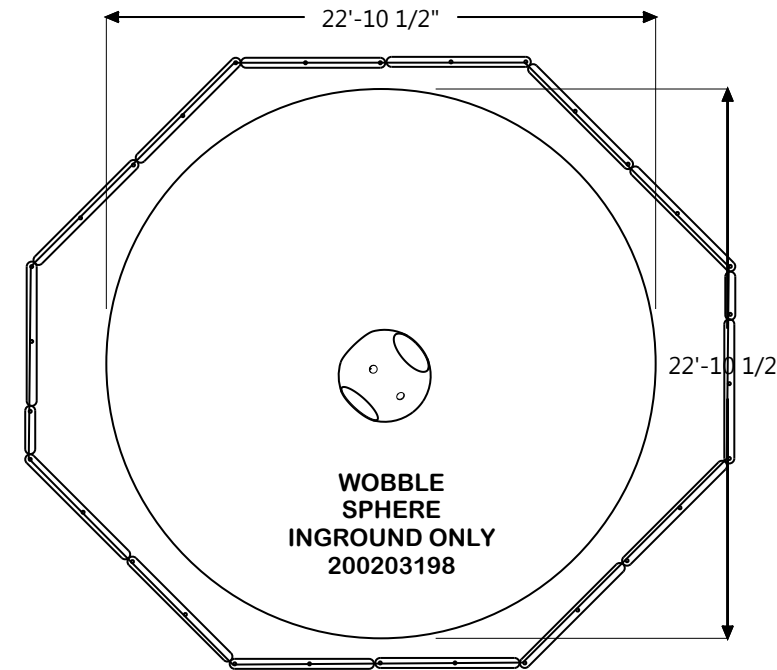
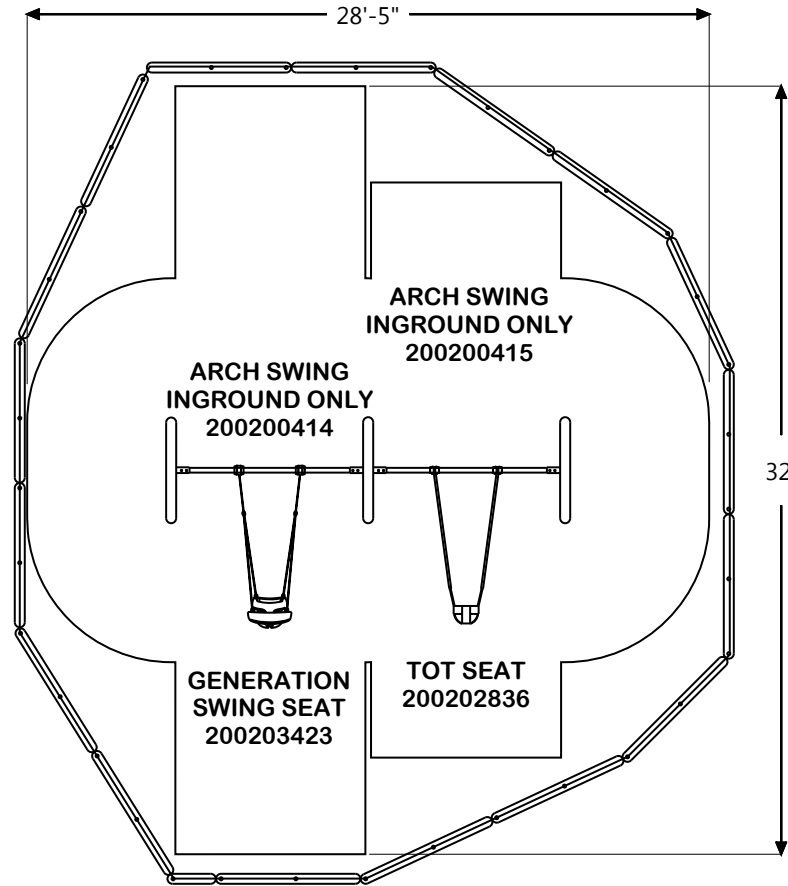

Project:
 Town of Golden Beach, North Park Rev 1
 Golden Beach, FL
LTCPS rep:
 Jennifer Garcia
 Playworx Playsets, LLC
 (866) 502-5013

Ground Space: 51'-0" x 9'-6"
Protective Area: 66'-6" x 32'-6"

Drawn by: Rich McCarver
Date: 1/17/2018
DWG Name: LP844_43117124500

LTCPS - Farmington
 878 East Highway 60
 Monett, Missouri 65708
Voice: 1-800-325-8828
Fax: 417-354-2273

Playground Layout Compliance:

- ASTM F1487 - Playground Equipment for Public Use.
- CPSC Handbook for Public Playground Safety

This playground design meets the final Access Board Regulations.



The play components identified in this plan are IPEMA certified. The use and layout of these components conform to the requirements of ASTM F1487.

LEED points for this structure
 1

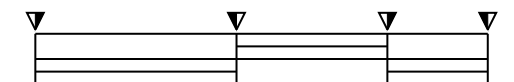
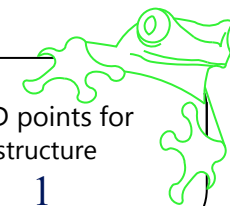

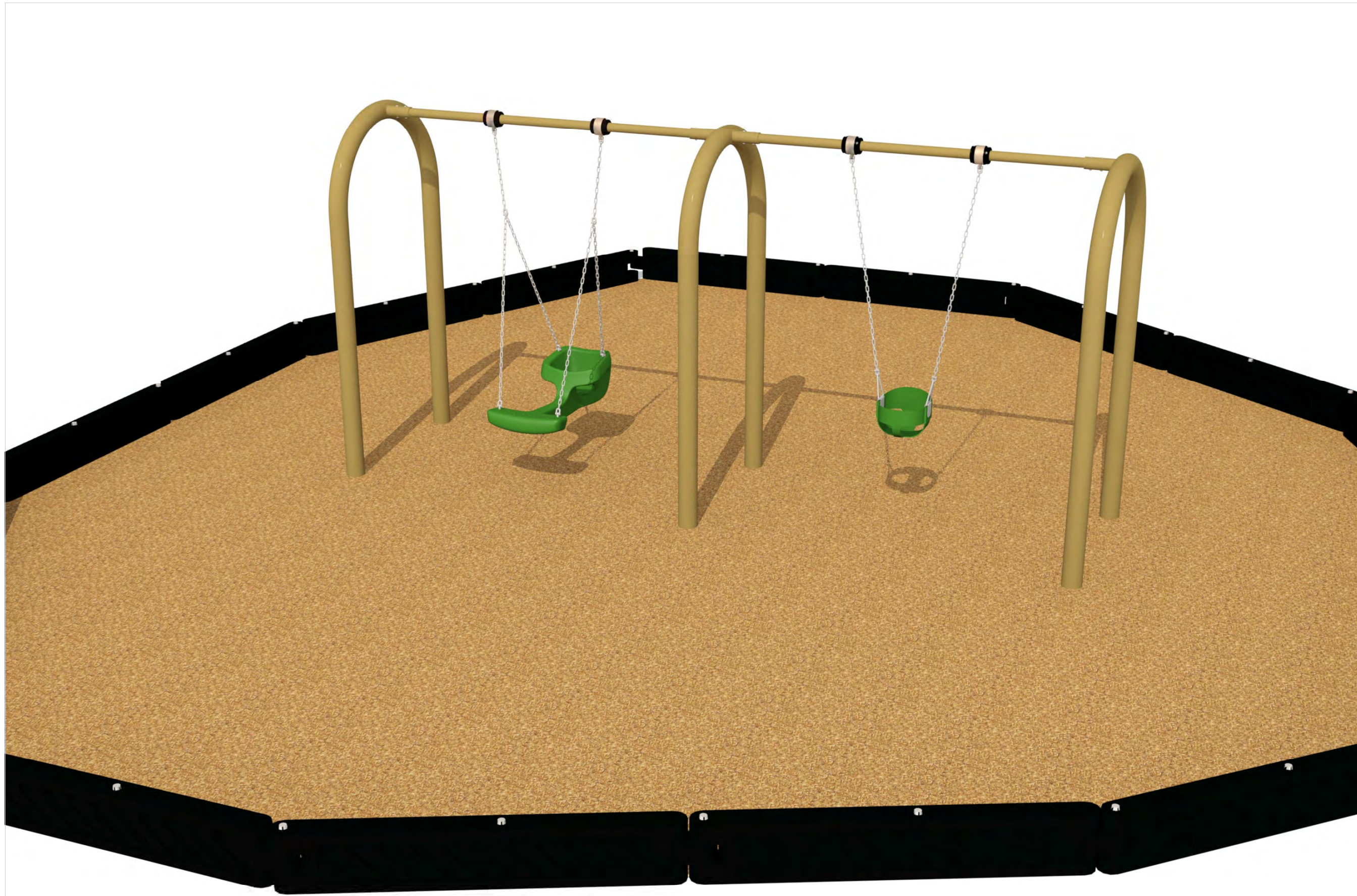

Playworx Playsets, LLC
Jennifer Garcia
2550 Sandy Plains Rd
Suite 225 #348
Marietta, GA

Town of Golden
Beach
North Park
Rev 1
Golden Beach, FL
R0321181008



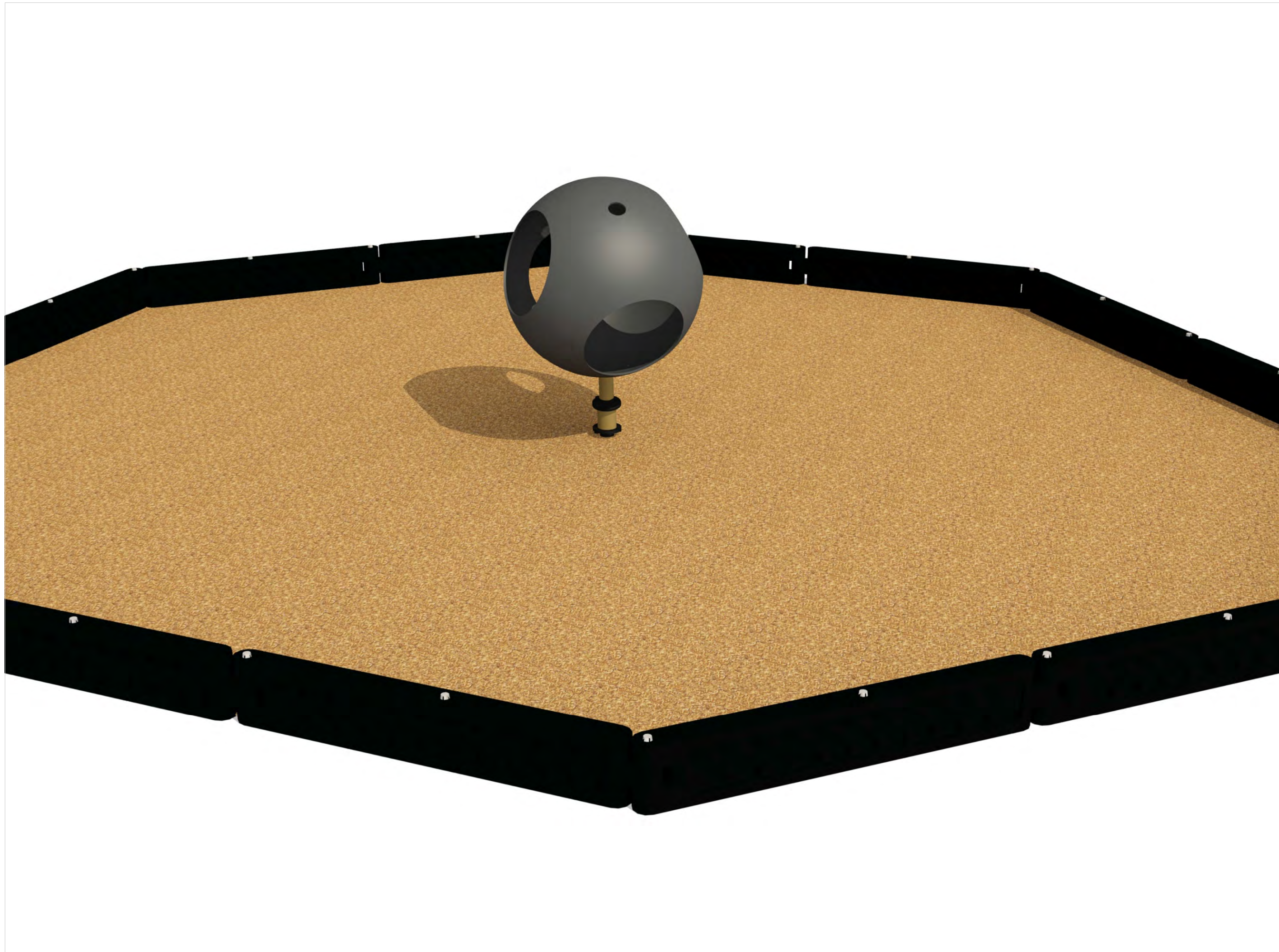

Playworx Playsets, LLC
Jennifer Garcia
2550 Sandy Plains Rd
Suite 225 #348
Marietta, GA

**Town of Golden
Beach
North Park
Rev 1**
Golden Beach, FL
R0321181008



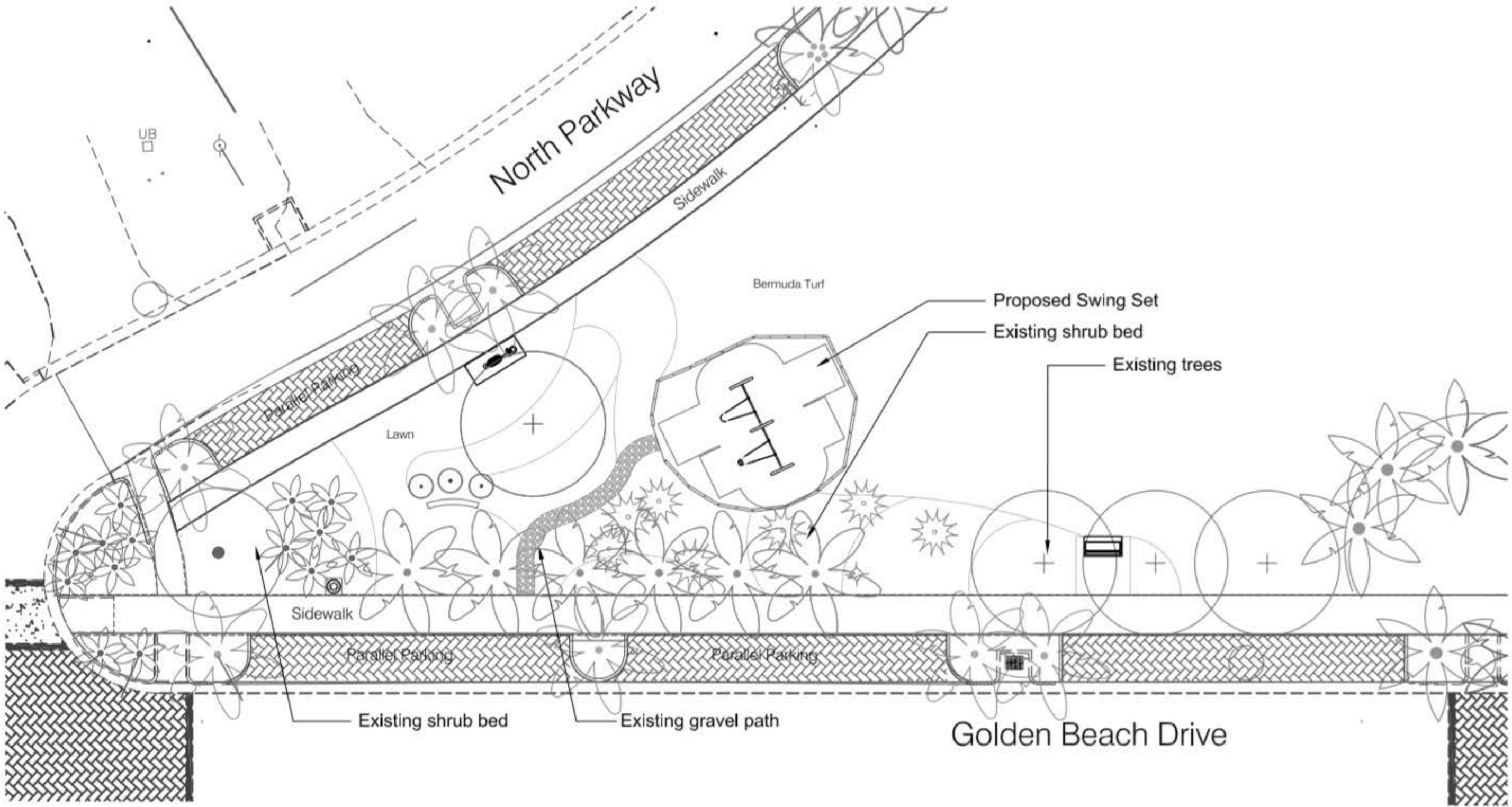

O'Leary
Richards
Design
Associates,
Inc.
Landscape Architecture
&
Planning
p. 305.596.6628 f. 305.596.9166
www.olearyrichards.com

NORTH PARK

Conceptual Site Plan for Play Equipment

Town of Golden Beach | Florida



0 16 32 FT

SCALE: 1/16" = 1' - 0"

January 18, 2018



SINGER PARK

Conceptual Site Plan for Play Equipment

Town of Golden Beach | Florida

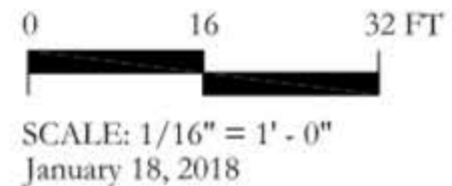

EXHIBIT B



PlayPower LT Farmington, Inc.
878 E. US Hwy 60
Monett, MO 65708
1-800-325-8828

Proj

Bill To:

Michael Gidden
Town of Golden Beach
Golden Beach, FL 33160

Project Name & Location:

Tweddle Park
Attn: Michael Glidden
Golden Beach, FL 33160

Prepared by:

Playworx Playsets, LLC
Jennifer Garcia
407-912-1693
jennifergarcia@playworx.com

Ship To Address:

Michael Gidden
Town of Golden Beach
Tweddle Park
Golden Beach, FL 33160

End User:

Michael Gidden
Town of Golden Beach
Tweddle Park
Golden Beach, FL 33160

Quote Number: R0321181016
Quote Date: 1/29/2018
Valid For: 30 Days From Quote Date

REPLACEMENT PARTS

Product line: KidBuilders
Age group: 2-12

Global defaults

Belt Swing Seat Color	RED
Inclusive Seat Clr	RED
KB Accent Color	RED
KB Vinyl color	RED
Kid Builder Post Color	RED
Tot Swing Seat Color	RED
Us/Csa Labels For Swings	US Swing Label

Components

Part Number	Description	Qty	Weight	Volume	Unit Price	Total
200054757	KB Swing Seat, tot assembly -(includes vinyl clad chains, hardware, and seat for 6' or 8' beams)	3	14.00	1.00	285.00	855.00
200054758	KB Swing Seat, belt assembly -(includes vinyl clad chains, hardware, and seat for 6' or 8' beams)	4	5.00	0.00	195.00	780.00
200200530	KIT MAINTENANCE KB W/PAINT	1	10.00	1.00	0.00	0.00
200203433	Inclusive Swing Seat with Chains 8'	1	45.00	14.00	970.00	970.00

PlayArea_1

Product line: KidBuilders

Age group: 2-12

Global defaults

KB/Jeep Ground Cover	Buried
Kid Builder Post Color	BLUE
Tire Color	RED
Tire Ground Mounting	Buried

Components

Part Number	Description	Qty	Weight	Volume	Unit Price	Total
200013795	Post, 3050 mm (10'),13 ga. galvanized w/cap	2	52.00	3.00	266.00	532.00
200203283	Tire Climb - with Inside Seats	1	145.00	0.00	919.00	919.00
200203435	KB ALEX'S LEMONADE STAND	1	41.00	14.00	1,025.00	1,025.00
8030565	Spin Rocker	1	169.00	69.50	3,169.00	3,169.00

PlayArea_2

Product line: Traditional Play

Age group: 13+

Global defaults

Lf_Station_Accent_Color	BLUE
Life_Fitness_Ground_Cover	Inground
Life_Fitness_Post_Color	RED
Life_Fitness_Vinyl_Clr_&_Ground_Cover	Brn/Ing
Life_Fitness_Vinyl_Color	Brown

Components

Part Number	Description	Qty	Weight	Volume	Unit Price	Total
100011805	LF SIGN ASSY F/1 SIGN W/TIKES LOGO	3	2.00	0.25	56.00	168.00
200203251	LF STEP STATION	1	115.00	7.00	1,203.00	1,203.00
200203254	LF ASSY EXERCISE STATION PRESS	1	70.00	7.00	1,090.00	1,090.00
200203259	LF ASSY EXERCISE STATION AB	1	120.00	36.00	1,343.00	1,343.00
200203262	LF ASSY 99" POSTS	3	65.00	2.00	249.00	747.00

Additional Items

Part Number	Description	Qty	Weight	Volume	Unit Price	Total
200111492	Label, Identification stamped w/rivets	3	0.00	0.00	0.00	0.00
200111492	Label, Identification stamped w/rivets	3	0.00	0.00	0.00	0.00
200305597	CRATE,LARGE.14' L X 54.5" H	1	385.00	0.00	0.00	0.00

Totals:

Equipment Weight:	1,467.00 lbs
Equipment Volume:	164.25 ft ³
Equipment List:	\$12,801.00
Discount Amount:	-\$2560.20
Products Subtotal:	\$10,240.80
Products by Other:	\$0.00
Installation:	\$4,864.00
Estimated Sales Tax*:	\$0.00
Freight:	\$1,051.25

Make Purchase Orders Out To:
PlayPower LT Farmington, Inc.
Remit Purchase Orders To:
PlayPower LT Farmington, Inc.
Attention: Sales Administration
878 E US Hwy 60
Monett, Missouri, USA 65708
1-800-325-8828

Make Checks Payable To:
PlayPower LT Farmington, Inc.
Remit Checks To:
PlayPower LT Farmington, Inc.
P.O. Box 204713
Dallas, TX 75320-4713

NOTE:

* Applicable sales taxes will be confirmed once order and any tax certificates are received
† Denotes drop ship item.
Unloading, storage, installation, surfacing and site work are not included unless specifically noted on quotation.
Not responsible for filter cloth, irrigation rerouting, grass damage, or checking for underground utilities.
If installation is quoted, it is assumed that the site has been prepared and that any grade slope in any direction does not exceed 2%. In the event that unexpected soil conditions, such as subsurface rock, are encountered during installation, additional costs to the customer will be applicable.
The acceptance signature below serves as authorization to order the items quoted and indicates acceptance of the prices listed. All terms are subject to credit approval.

COMMENTS:

This Quote shall not become a binding contract until signed and delivered by both Customer and PlayPower LT Farmington Inc ("PPLT"). Sales Representative is not authorized to sign this Quote on behalf of PPLT or Customer, and signed Quotes cannot be accepted from Sales Representative. To submit this offer, please sign below and forward a complete signed copy of this Quote directly to "PPLT Sales Administration" via fax (417)354-2273 or email outdoordes@LTCPS.com. Upon acceptance, PPLT will return a fully-signed copy of the Quote to Customer (with copy to Sales Representative) via fax or e mail.

THIS QUOTE IS LIMITED TO AND GOVERNED BY THE TERMS CONTAINED HEREIN. PPLT objects to any other terms proposed by Customer, in writing or otherwise, as material alterations, and all such proposed terms shall be void. Customer authorizes PPLT to ship the Equipment and agrees to pay PPLT the total amount specified. Shipping terms are FOB the place of shipment via common carrier designated by PPLT. Payment terms are Net-30 days from invoice date with approved credit and all charges are due and payable in full at PO Box 204713, Dallas, TX 75320-4713, unless notified otherwise by PPLT in writing. Customer agrees to pay all additional service charges for past due invoices. Customer must provide proper tax exemption certificates to PPLT, and shall promptly pay and discharge all otherwise applicable taxes, license fees, levies and other impositions on the Equipment at its own expense.

CUSTOMER HEREBY SUBMITS ITS OFFER TO PURCHASE THE EQUIPMENT ACCORDING TO THE TERMS STATED IN THIS QUOTE AND SUBJECT TO FINAL APPROVAL BY PPLT.

Submitted By **Printed Name and Title** **Date**

THE FOREGOING QUOTE AND OFFER ARE HEREBY APPROVED AND ACCEPTED BY PLAYPOWER LT FARMINGTON INC.

By: _____ Date: _____

1. Use & Maintenance. Customer agrees to regularly inspect and maintain the Equipment, and to provide, inspect and maintain appropriate safety surfacing under and around the Equipment, in accordance with PPLT's product literature and the most current Consumer Product Safety Commission Handbook for Public Playground Safety.

2. Default, Remedies & Delinquency Charges. Customer's failure to pay any invoice when due, or its failure to otherwise comply with the terms of this Quote, shall constitute a default under all unsatisfied invoices ("Event of Default"). Upon an Event of Default, PPLT shall have all remedies available to it at law or equity, including, without limitation, all remedies afforded a secured creditor under the Uniform Commercial Code. Customer agrees to assist and cooperate with PPLT to accomplish its filing and enforcement of mechanic's or other liens with respect to the Equipment or its location or its repossession of the Equipment, and Customer expressly waives all rights to possess the Equipment after an Event of Default. All remedies are cumulative and not alternative, and no exercise by PPLT of a remedy will prohibit or waive the exercise of any other remedy. Customer shall pay all reasonable attorneys' fees plus any costs of collection incurred by PPLT in enforcing its rights hereunder. Subject to any limitations under law, Customer shall pay to PPLT as liquidated damages, and not as a penalty, an amount equal to 1.5% per month of any payment that is delinquent in such month and is not received by PPLT within ten (10) days after the date on which due.

3. Limitation of Warranty/ Indemnity. PPLT MAKES NO EQUIPMENT WARRANTIES EXCEPT FOR THOSE STANDARD WARRANTIES ISSUED WITH THE EQUIPMENT, WHICH ARE INCORPORATED HEREIN BY THIS REFERENCE. PPLT SPECIFICALLY DISCLAIMS ANY IMPLIED WARRANTY OF MERCHANTABILITY OR FITNESS FOR A PARTICULAR PURPOSE AND ANY LIABILITY FOR INCIDENTAL OR CONSEQUENTIAL DAMAGES. CUSTOMER AGREES TO DEFEND, INDEMNIFY AND SAVE PPLT HARMLESS FROM ALL CLAIMS OF ANY KIND FOR DAMAGES OF ANY KIND ARISING OUT OF CUSTOMER'S ALTERATION OF THE EQUIPMENT, ITS FAILURE TO MAINTAIN THE EQUIPMENT, ITS FAILURE TO PROPERLY SUPERVISE EQUIPMENT USE, OR ITS FAILURE TO PROVIDE AND MAINTAIN APPROPRIATE TYPES AND DEPTHS OF SAFETY SURFACING BENEATH AND AROUND THE EQUIPMENT IN ACCORDANCE WITH PPLT'S INSTALLATION AND OWNER'S MANUALS AND THE MOST CURRENT CONSUMER PRODUCT SAFETY COMMISSION HANDBOOK FOR PUBLIC PLAYGROUND SAFETY.

4. Restrictions. Until all amounts due hereunder are paid in full, Customer shall not: (i) permit the Equipment to be levied upon or attached under any legal process; (ii) transfer title to the Equipment or any of Customer's rights therein; or (iii) remove or permit the removal of the Equipment to any location not specified in this Quote.

5. Purchase Money Security Interest. Customer hereby grants, pledges and assigns to PPLT, and PPLT hereby reserves a purchase money security interest in, the Equipment in order to secure the payment and performance in full of all of Customer's obligations hereunder. Customer agrees that PPLT may file one or more financing statements, in order to allow it to perfect, acquire and maintain a superior security interest in the Equipment.

6. Choice of Law and Jurisdiction. All agreements between Customer and PPLT shall be interpreted, and the parties' obligations shall be governed, by the laws of the State of Missouri without reference to its choice of law provisions. Customer hereby consents to the personal jurisdiction of the state and federal courts located in the city and county of St. Louis, Missouri.

7. Title; Risk of Loss; Insurance. PPLT Retains full title to all Equipment until full payment is received by PPLT. Customer assumes all risk of loss or destruction of or damage to the Equipment by reason of theft, fire, water, or any other cause, and the occurrence of any such casualty shall not relieve the Customer from its obligations hereunder and under any invoices. Until all amounts due hereunder are paid in full, Customer shall insure the Equipment against all such losses and casualties.

8. Waiver; Invalidity. PPLT may waive a default hereunder, or under any invoice or other agreement between Customer and PPLT, or cure such a default at Customer's expense, but shall have no obligation to do either. No waiver shall be deemed to have taken place unless it is in writing, signed by PPLT. Any one waiver shall not constitute a waiver of other defaults or the same kind of default at another time, or a forfeiture of any rights provided to PPLT hereunder or under any invoice. The invalidity of any portion of this Quote shall not affect the force and effect of the remaining valid portions hereof.

9. Entire Agreement; Amendment; Binding Nature. This fully-executed Quote, as supplemented by Change Orders and invoices containing exact amounts of estimates provided herein, constitutes the complete and exclusive agreement between the parties. A Change Order is a written instrument signed by the Customer and PPLT stating their agreement as to any amendment in the terms of this Quote. Customer acknowledges that Change Orders may result in delays and additional costs. The parties agree that all Change Orders shall include appropriate adjustments in price and time frames relating to any requested amendments. Upon full execution, this Quote shall be binding upon and inure to the benefit of the parties and their successors and assigns.

10. Counterparts; Electronic Transmission. This Quote, any invoice, and any other agreement between the parties, may be executed in counterparts, each of which shall constitute an original. The facsimile or other electronic transmission of any signed original document, and retransmission of any signed facsimile or other electronic transmission, shall be the same as the transmission of an original. At the request of either party, the parties will confirm facsimile or other electronically transmitted signatures by signing an original document.

General Notes:

Age Group

2-5yrs 5-12 yrs 2-12yrs 13+ yrs

1. The Americans with Disabilities Act (ADA) may require that you make your park and/or playground accessible when viewed in its entirety. Please consult your legal counsel to determine if the ADA applies to you.
2. For playground equipment to be considered accessible, accessible surfacing must be utilized in applicable areas.
3. Although a particular playground design may not meet the proposed Access Board Regulations in regards to the appropriate number of ground level events, the actual playground may be in compliance when considering existing play components.
4. All deck heights are measured from top of ground cover.
5. Fall absorbing ground cover is required under and around all play equipment.
6. The minimum recommended fall zone around the entire playstructure is shown. This zone is to be free of all tripping or collision hazards (i.e. roots, rocks, border material, etc.).
7. All post lengths are identified by text showing the post lengths, i.e. 96 represents a 96 inch post.
8. Not all equipment may be appropriate for all children. Supervision is required.

AGE GROUP: 2-12
 ELEVATED PLAY ACTIVITIES - TOTAL: 0
 ELEVATED PLAY ACTIVITIES ACCESSIBLE BY TRANSFER: 0 REQ'D 0
 ELEVATED PLAY ACTIVITIES ACCESSIBLE BY RAMP: 0 REQ'D 0
 GROUND LEVEL ACTIVITY TYPE: 3 REQ'D 0
 GROUND LEVEL QUANTITY: 2 REQ'D 0

AREA: 189 ft²
 PERIMETER: 48 ft



AREA: 197 ft²
 PERIMETER: 50 ft
 The information provided is for estimation purposes only.

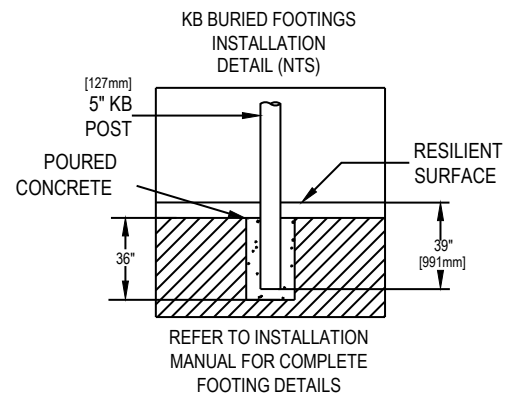
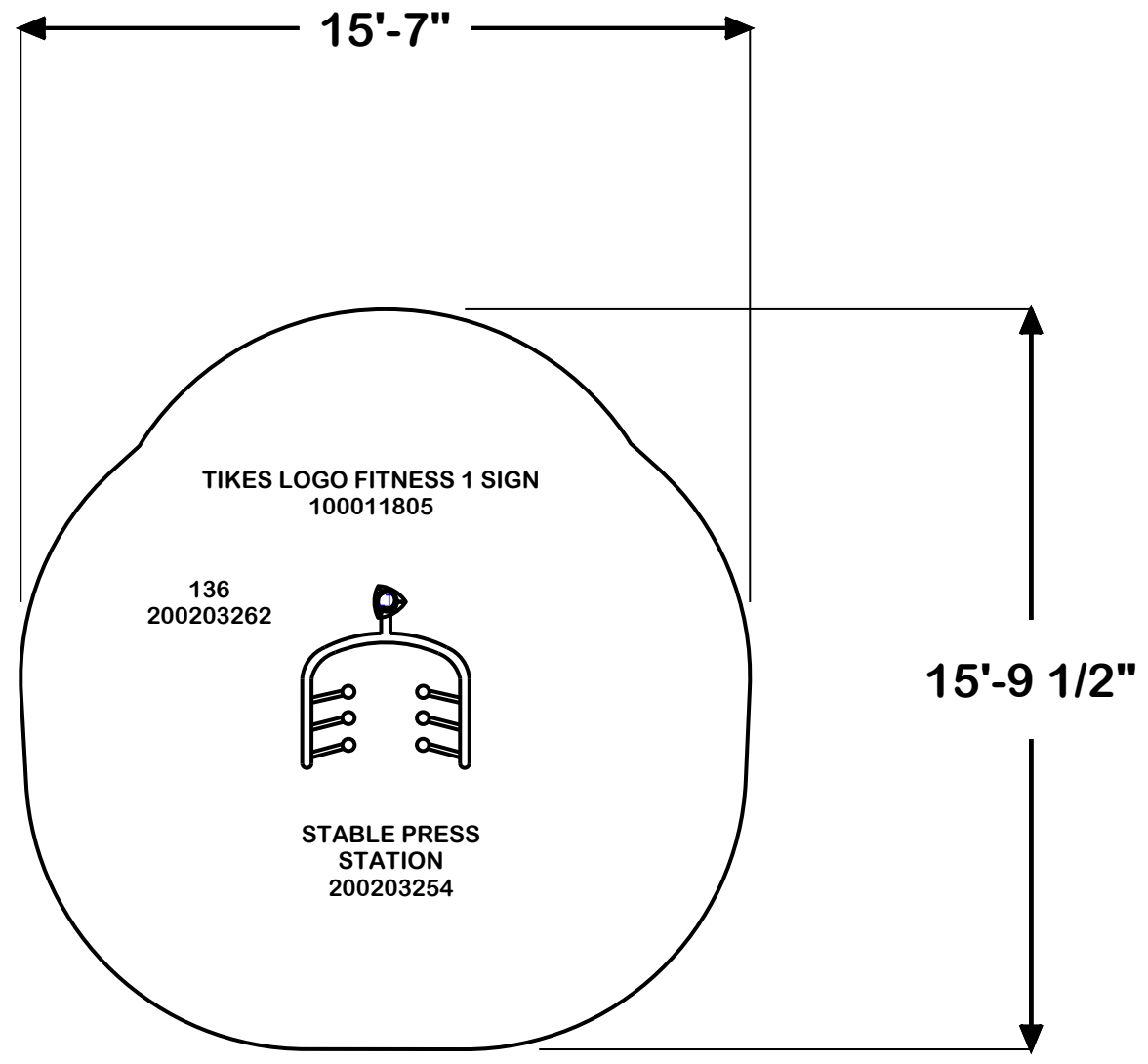

Project:
 Tweddle Park
 Golden Beach, FL
LTCPS rep:
 Jennifer Garcia
 Playworx Playsets, LLC
 (866) 502-5013

Ground Space: 190'-0" x 88'-6"
Protective Area: 205'-0" x 100'-6"

Drawn by: Rich McCarver
Date: 1/29/2018
DWG Name: LP844_43129513304

LTCPS - Farmington
 878 East Highway 60
 Monett, Missouri 65708
Voice: 1-800-325-8828
Fax: 417-354-2273

Playground Layout Compliance:

- ASTM F1487 - Playground Equipment for Public Use.
- CPSC Handbook for Public Playground Safety
- This playground design meets the final Access Board Regulations.



The play components identified in this plan are IPEMA certified. The use and layout of these components conform to the requirements of ASTM F1487.

LEED points for this structure
 0

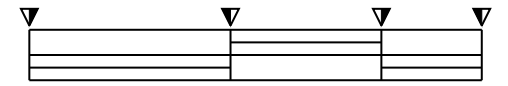

General Notes:

Age Group

2-5yrs 5-12 yrs 2-12yrs 13+ yrs

1. The Americans with Disabilities Act (ADA) may require that you make your park and/or playground accessible when viewed in its entirety. Please consult your legal counsel to determine if the ADA applies to you.
2. For playground equipment to be considered accessible, accessible surfacing must be utilized in applicable areas.
3. Although a particular playground design may not meet the proposed Access Board Regulations in regards to the appropriate number of ground level events, the actual playground may be in compliance when considering existing play components.
4. All deck heights are measured from top of ground cover.
5. Fall absorbing ground cover is required under and around all play equipment.
6. The minimum recommended fall zone around the entire playstructure is shown. This zone is to be free of all tripping or collision hazards (i.e. roots, rocks, border material, etc.).
7. All post lengths are identified by text showing the post lengths, i.e. '96 represents a 96 inch post.
8. Not all equipment may be appropriate for all children. Supervision is required.

AGE GROUP: 2-12
 ELEVATED PLAY ACTIVITIES - TOTAL: 0
 ELEVATED PLAY ACTIVITIES ACCESSIBLE BY TRANSFER: 0 REQ'D 0
 ELEVATED PLAY ACTIVITIES ACCESSIBLE BY RAMP: 0 REQ'D 0
 GROUND LEVEL ACTIVITY TYPE: 3 REQ'D 0
 GROUND LEVEL QUANTITY: 2 REQ'D 0

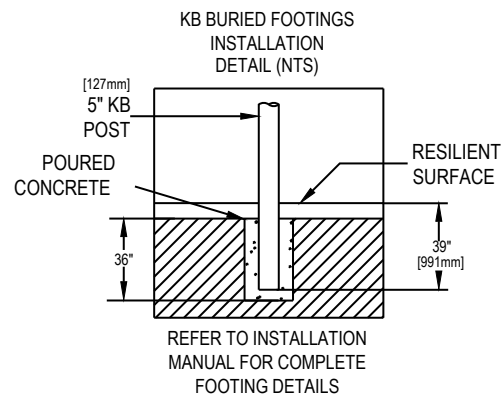
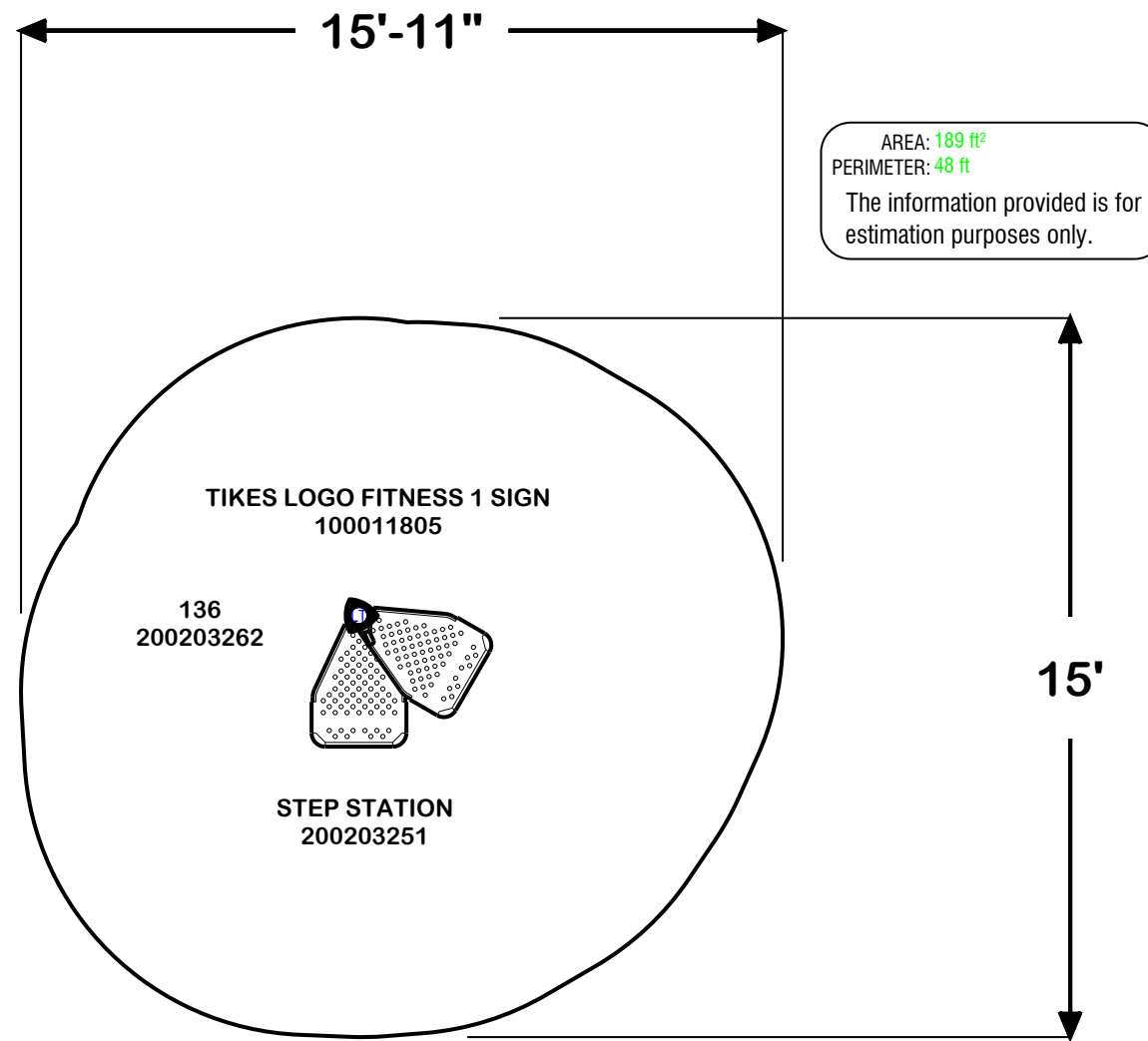

Project:
 Tweddle Park
 Golden Beach, FL
 LTCPS rep:
 Jennifer Garcia
 Playworx Playsets, LLC
 (866) 502-5013

Ground Space: 190'-0" x 88'-6"
Protective Area: 205'-0" x 100'-6"

Drawn by: Rich McCarver
Date: 1/29/2018
DWG Name: LP844_43129513304

LTCPS - Farmington
 878 East Highway 60
 Monett, Missouri 65708
 Voice: 1-800-325-8828
 Fax: 417-354-2273

Playground Layout Compliance:

- ASTM F1487 - Playground Equipment for Public Use.
- CPSC Handbook for Public Playground Safety

This playground design meets the final Access Board Regulations.



The play components identified in this plan are IPEMA certified. The use and layout of these components conform to the requirements of ASTM F1487.

LEED points for this structure
 0

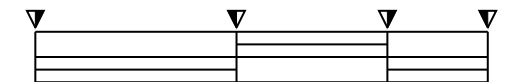
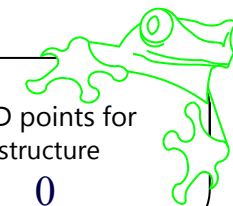

General Notes:

Age Group

2-5yrs 5-12 yrs 2-12yrs 13+ yrs

1. The Americans with Disabilities Act (ADA) may require that you make your park and/or playground accessible when viewed in its entirety. Please consult your legal counsel to determine if the ADA applies to you.
2. For playground equipment to be considered accessible, accessible surfacing must be utilized in applicable areas.
3. Although a particular playground design may not meet the proposed Access Board Regulations in regards to the appropriate number of ground level events, the actual playground may be in compliance when considering existing play components.
4. All deck heights are measured from top of ground cover.
5. Fall absorbing ground cover is required under and around all play equipment.
6. The minimum recommended fall zone around the entire playstructure is shown. This zone is to be free of all tripping or collision hazards (i.e. roots, rocks, border material, etc.).
7. All post lengths are identified by text showing the post lengths, i.e. 96 represents a 96 inch post.
8. Not all equipment may be appropriate for all children. Supervision is required.

AGE GROUP: 2-12
 ELEVATED PLAY ACTIVITIES - TOTAL: 0
 ELEVATED PLAY ACTIVITIES ACCESSIBLE BY TRANSFER: 0 REQ'D 0
 ELEVATED PLAY ACTIVITIES ACCESSIBLE BY RAMP: 0 REQ'D 0
 GROUND LEVEL ACTIVITY TYPE: 3 REQ'D 0
 GROUND LEVEL QUANTITY: 2 REQ'D 0



AREA: 207 ft²
 PERIMETER: 51 ft
 The information provided is for estimation purposes only.

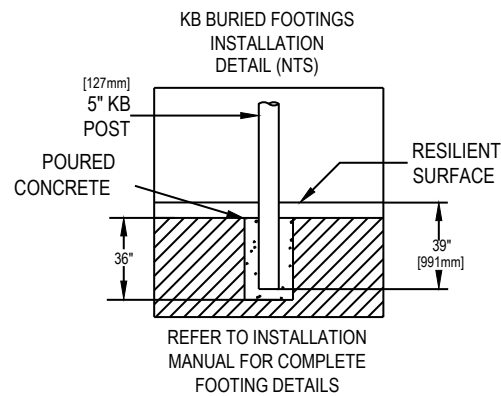
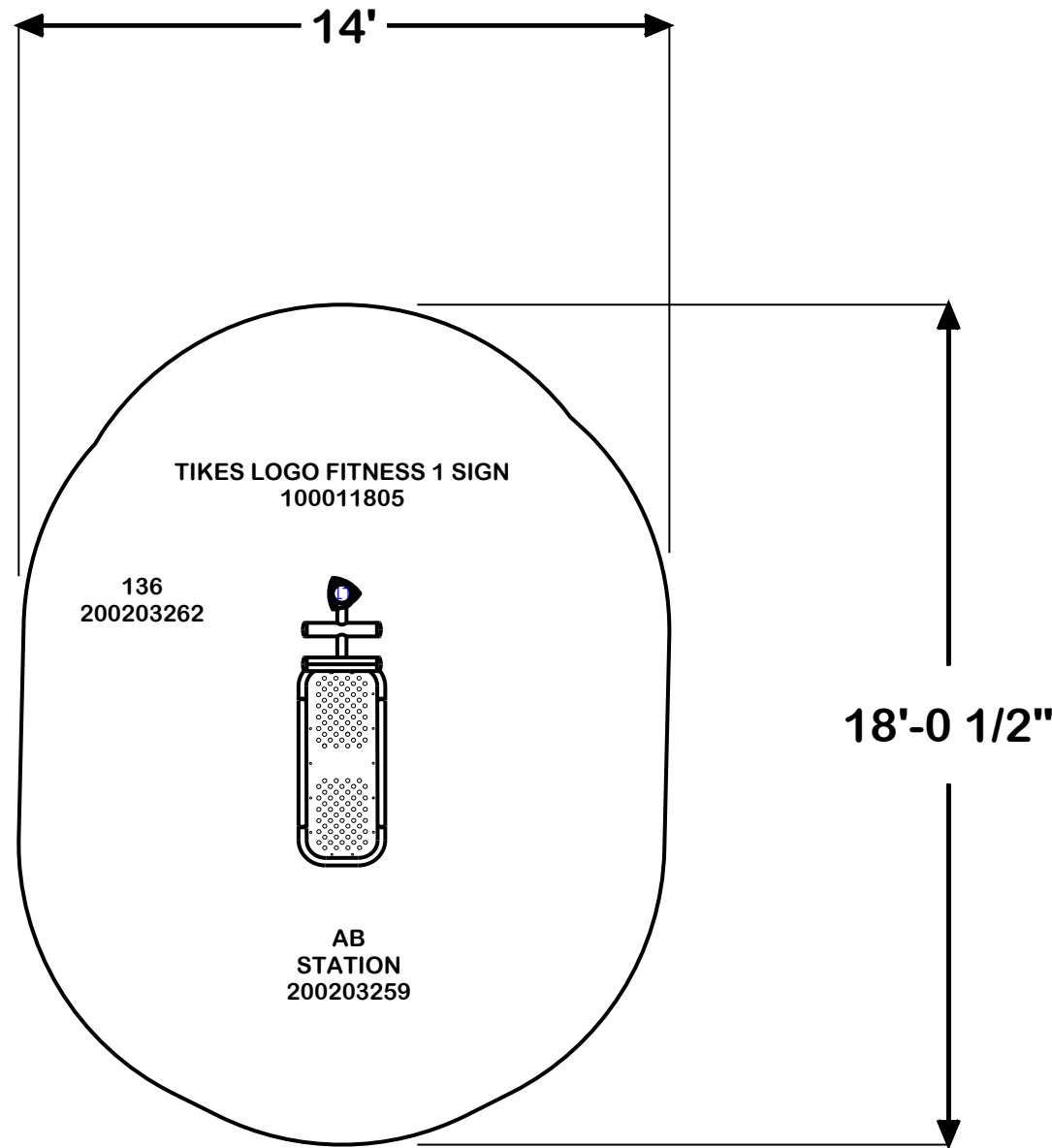

Project:
 Tweddle Park
 Golden Beach, FL
LTCPS rep:
 Jennifer Garcia
 Playworx Playsets, LLC
 (866) 502-5013

Ground Space: 190'-0" x 88'-6"
Protective Area: 205'-0" x 100'-6"

Drawn by: Rich McCarver
Date: 1/29/2018
DWG Name: LP844_43129513304

LTCPS - Farmington
 878 East Highway 60
 Monett, Missouri 65708
Voice: 1-800-325-8828
Fax: 417-354-2273

Playground Layout Compliance:

- ASTM F1487 - Playground Equipment for Public Use.
- CPSC Handbook for Public Playground Safety

This playground design meets the final Access Board Regulations.



The play components identified in this plan are IPEMA certified. The use and layout of these components conform to the requirements of ASTM F1487.

LEED points for this structure
 0

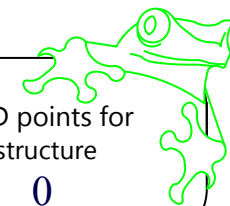

General Notes:

Age Group

2-5yrs 5-12 yrs 2-12yrs 13+ yrs

1. The Americans with Disabilities Act (ADA) may require that you make your park and/or playground accessible when viewed in its entirety. Please consult your legal counsel to determine if the ADA applies to you.
2. For playground equipment to be considered accessible, accessible surfacing must be utilized in applicable areas.
3. Although a particular playground design may not meet the proposed Access Board Regulations in regards to the appropriate number of ground level events, the actual playground may be in compliance when considering existing play components.
4. All deck heights are measured from top of ground cover.
5. Fall absorbing ground cover is required under and around all play equipment.
6. The minimum recommended fall zone around the entire playstructure is shown. This zone is to be free of all tripping or collision hazards (i.e. roots, rocks, border material, etc.).
7. All post lengths are identified by text showing the post lengths, i.e. 96 represents a 96 inch post.
8. Not all equipment may be appropriate for all children. Supervision is required.

AGE GROUP: 2-12
 ELEVATED PLAY ACTIVITIES - TOTAL: 0
 ELEVATED PLAY ACTIVITIES ACCESSIBLE BY TRANSFER: 0 REQ'D 0
 ELEVATED PLAY ACTIVITIES ACCESSIBLE BY RAMP: 0 REQ'D 0
 GROUND LEVEL ACTIVITY TYPE: 3 REQ'D 0
 GROUND LEVEL QUANTITY: 2 REQ'D 0



AREA: 360 ft²
 PERIMETER: 67 ft
 The information provided is for estimation purposes only.

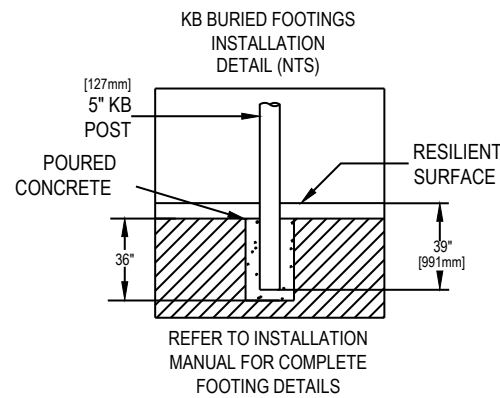
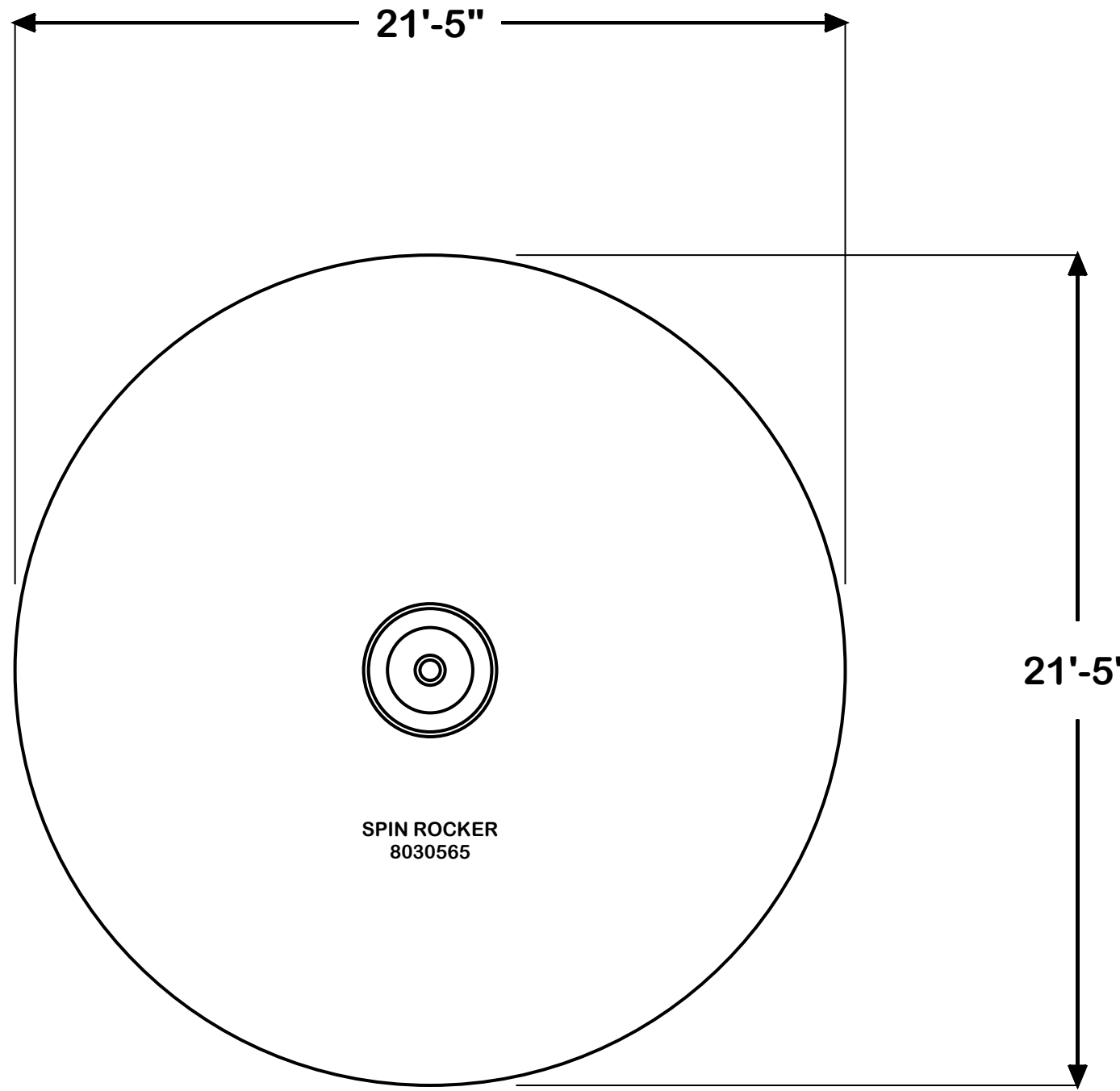

Project:
 Tweddle Park
 Golden Beach, FL
 LTCPS rep:
 Jennifer Garcia
 Playworx Playsets, LLC
 (866) 502-5013

Ground Space: 190'-0" x 88'-6"
Protective Area: 205'-0" x 100'-6"

Drawn by: Rich McCarver
Date: 1/29/2018
DWG Name: LP844_43129513304

LTCPS - Farmington
 878 East Highway 60
 Monett, Missouri 65708
 Voice: 1-800-325-8828
 Fax: 417-354-2273

Playground Layout Compliance:

- ASTM F1487 - Playground Equipment for Public Use.
- CPSC Handbook for Public Playground Safety

This playground design meets the final Access Board Regulations.



The play components identified in this plan are IPEMA certified. The use and layout of these components conform to the requirements of ASTM F1487.

LEED points for this structure
 0

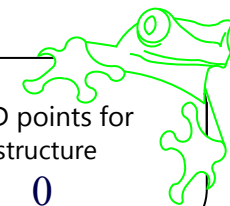

General Notes:

Age Group

2-5yrs 5-12 yrs 2-12yrs 13+ yrs

1. The Americans with Disabilities Act (ADA) may require that you make your park and/or playground accessible when viewed in its entirety. Please consult your legal counsel to determine if the ADA applies to you.
2. For playground equipment to be considered accessible, accessible surfacing must be utilized in applicable areas.
3. Although a particular playground design may not meet the proposed Access Board Regulations in regards to the appropriate number of ground level events, the actual playground may be in compliance when considering existing play components.
4. All deck heights are measured from top of ground cover.
5. Fall absorbing ground cover is required under and around all play equipment.
6. The minimum recommended fall zone around the entire playstructure is shown. This zone is to be free of all tripping or collision hazards (i.e. roots, rocks, border material, etc.).
7. All post lengths are identified by text showing the post lengths, i.e. 96 represents a 96 inch post.
8. Not all equipment may be appropriate for all children. Supervision is required.

AGE GROUP: 2-12
 ELEVATED PLAY ACTIVITIES - TOTAL: 0
 ELEVATED PLAY ACTIVITIES ACCESSIBLE BY TRANSFER: 0 REQ'D 0
 ELEVATED PLAY ACTIVITIES ACCESSIBLE BY RAMP: 0 REQ'D 0
 GROUND LEVEL ACTIVITY TYPE: 3 REQ'D 0
 GROUND LEVEL QUANTITY: 2 REQ'D 0

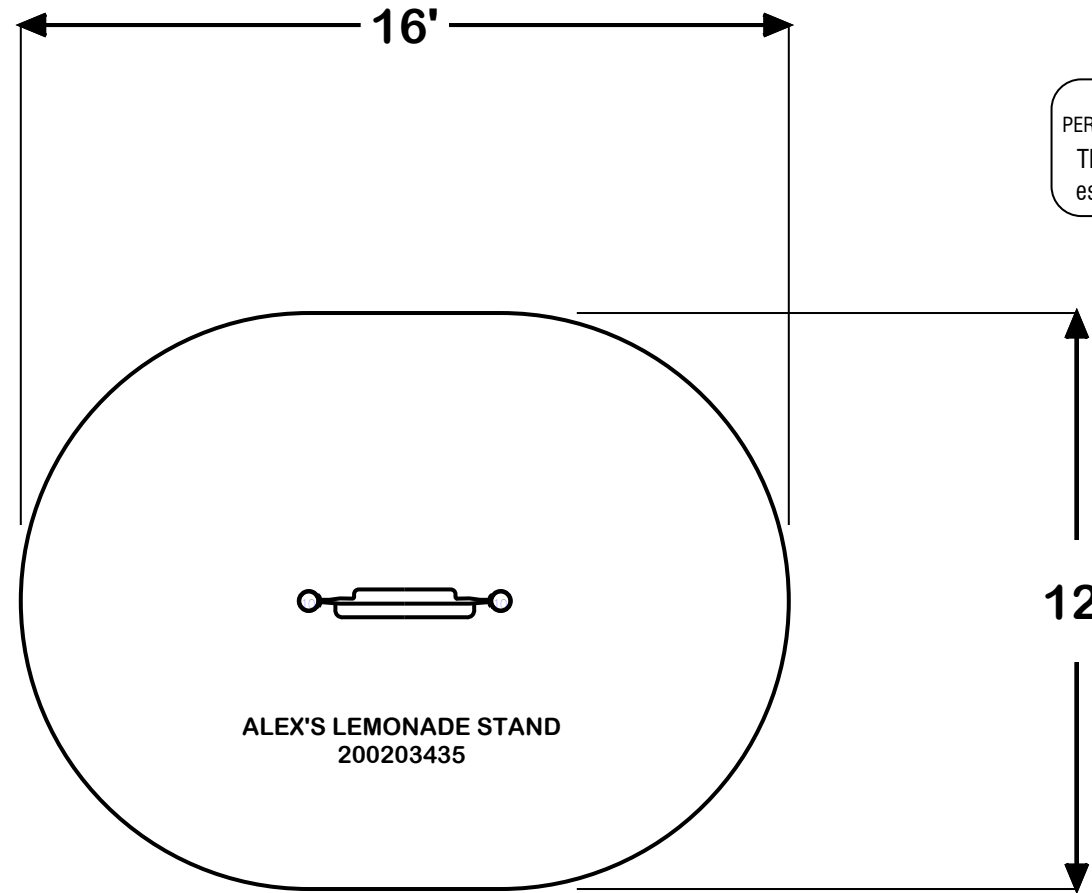

AREA: 161 ft²
 PERIMETER: 45 ft
 The information provided is for estimation purposes only.

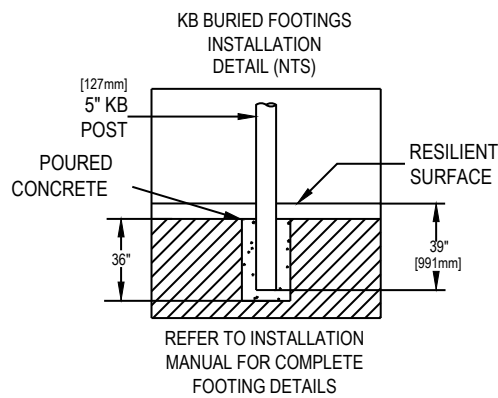

Project:
 Tweddle Park
 Golden Beach, FL
 LTCPS rep:
 Jennifer Garcia
 Playworx Playsets, LLC
 (866) 502-5013

Ground Space: 190'-0" x 88'-6"
Protective Area: 205'-0" x 100'-6"

Drawn by: Rich McCarver
Date: 1/29/2018
DWG Name: LP844_43129513304

LTCPS - Farmington
 878 East Highway 60
 Monett, Missouri 65708
 Voice: 1-800-325-8828
 Fax: 417-354-2273

Playground Layout Compliance:

- ASTM F1487 - Playground Equipment for Public Use.
- CPSC Handbook for Public Playground Safety

This playground design meets the final Access Board Regulations.



The play components identified in this plan are IPEMA certified. The use and layout of these components conform to the requirements of ASTM F1487.

LEED points for this structure
 0

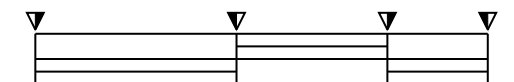
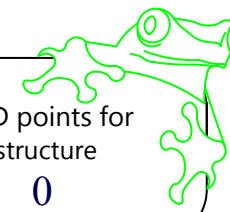

General Notes:

Age Group

2-5yrs 5-12 yrs 2-12yrs 13+ yrs

1. The Americans with Disabilities Act (ADA) may require that you make your park and/or playground accessible when viewed in its entirety. Please consult your legal counsel to determine if the ADA applies to you.
2. For playground equipment to be considered accessible, accessible surfacing must be utilized in applicable areas.
3. Although a particular playground design may not meet the proposed Access Board Regulations in regards to the appropriate number of ground level events, the actual playground may be in compliance when considering existing play components.
4. All deck heights are measured from top of ground cover.
5. Fall absorbing ground cover is required under and around all play equipment.
6. The minimum recommended fall zone around the entire playstructure is shown. This zone is to be free of all tripping or collision hazards (i.e. roots, rocks, border material, etc.).
7. All post lengths are identified by text showing the post lengths, i.e. 96 represents a 96 inch post.
8. Not all equipment may be appropriate for all children. Supervision is required.

AGE GROUP: 2-12
 ELEVATED PLAY ACTIVITIES - TOTAL: 0
 ELEVATED PLAY ACTIVITIES ACCESSIBLE BY TRANSFER: 0 REQ'D 0
 ELEVATED PLAY ACTIVITIES ACCESSIBLE BY RAMP: 0 REQ'D 0
 GROUND LEVEL ACTIVITY TYPE: 3 REQ'D 0
 GROUND LEVEL QUANTITY: 2 REQ'D 0



AREA: 198 ft²
 PERIMETER: 50 ft
 The information provided is for estimation purposes only.

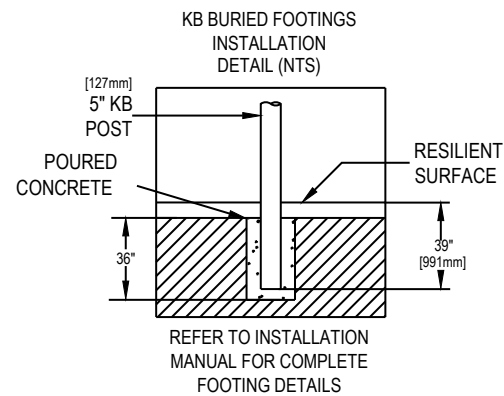
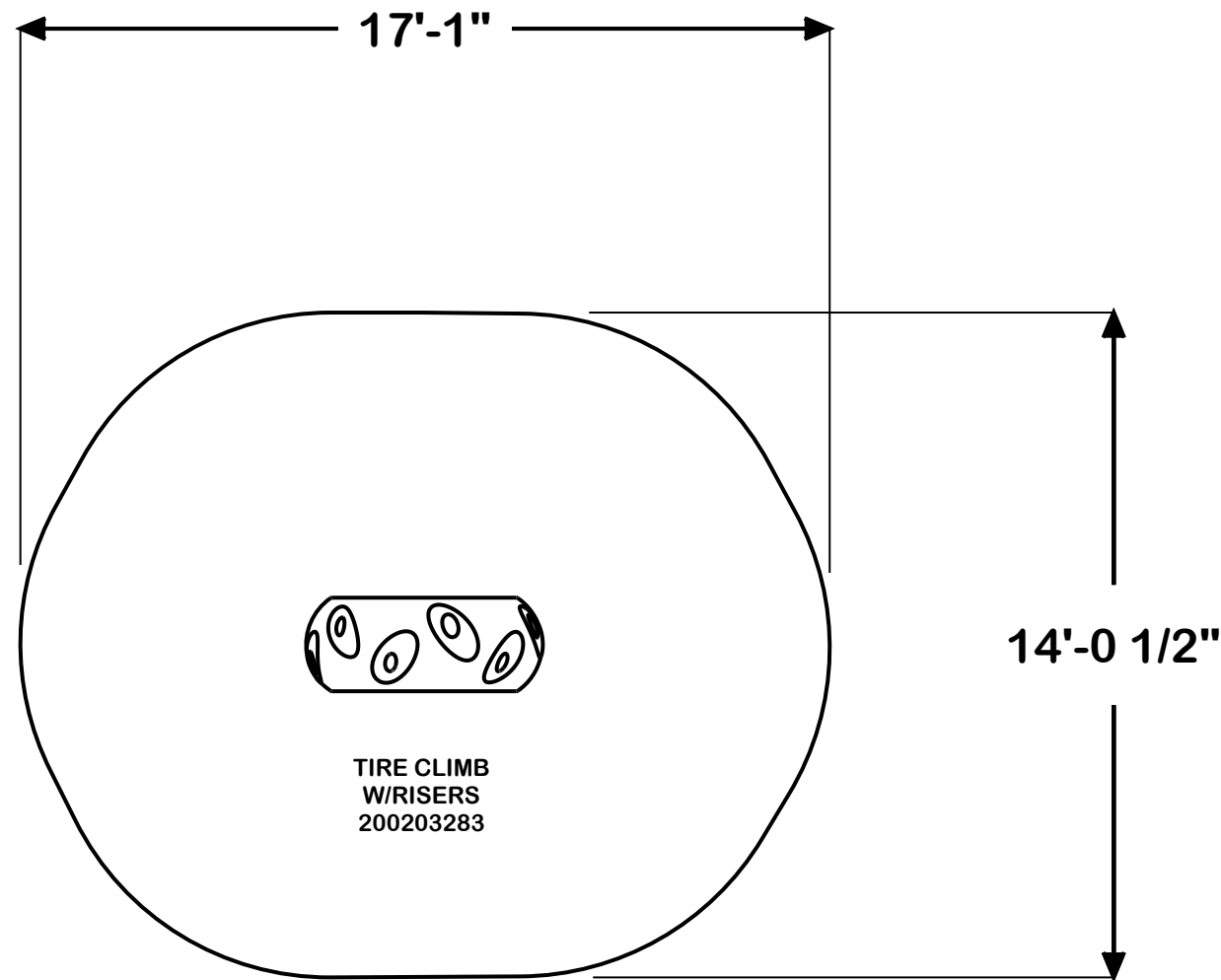

Project:
 Tweddle Park
 Golden Beach, FL
LTCPS rep:
 Jennifer Garcia
 Playworx Playsets, LLC
 (866) 502-5013

Ground Space: 190'-0" x 88'-6"
Protective Area: 205'-0" x 100'-6"

Drawn by: Rich McCarver
Date: 1/29/2018
DWG Name: LP844_43129513304

LTCPS - Farmington
 878 East Highway 60
 Monett, Missouri 65708
Voice: 1-800-325-8828
Fax: 417-354-2273

Playground Layout Compliance:

- ASTM F1487 - Playground Equipment for Public Use.
- CPSC Handbook for Public Playground Safety

This playground design meets the final Access Board Regulations.



The play components identified in this plan are IPEMA certified. The use and layout of these components conform to the requirements of ASTM F1487.

LEED points for this structure
 0

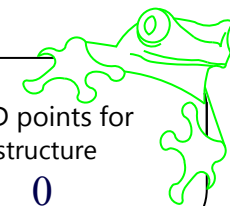



Playworx Playsets, LLC
Jennifer Garcia
2550 Sandy Plains Rd
Suite 225 #348
Marietta, GA

Town of Golden
Beach
Tweddle Park
Golden Beach, FL
R0321181016



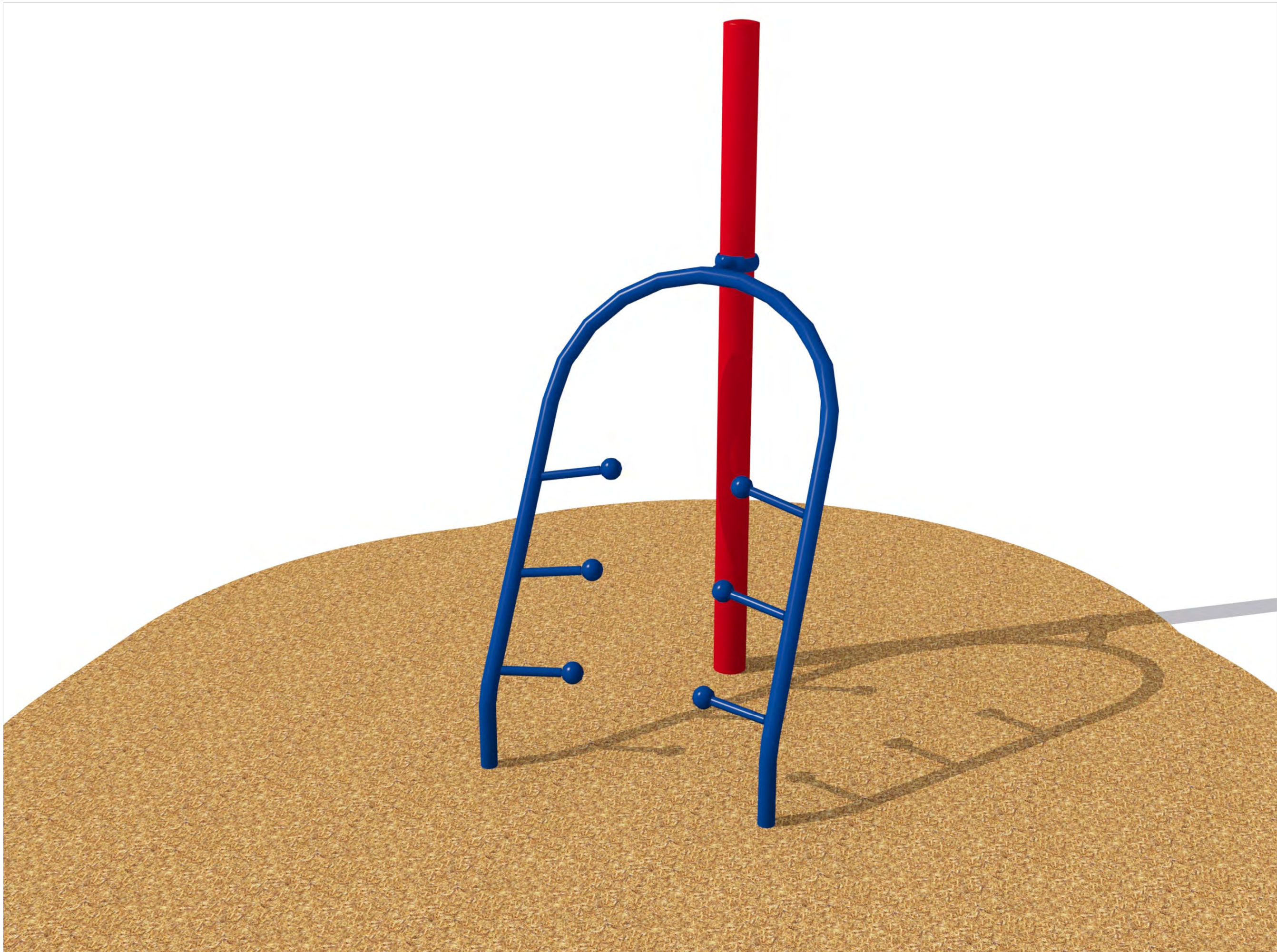

Playworx Playsets, LLC
Jennifer Garcia
2550 Sandy Plains Rd
Suite 225 #348
Marietta, GA

**Town of Golden
Beach
Tweddle Park
Golden Beach, FL
R0321181016**





Playworx Playsets, LLC
Jennifer Garcia
2550 Sandy Plains Rd
Suite 225 #348
Marietta, GA

**Town of Golden
Beach
Tweddle Park
Golden Beach, FL
R0321181016**



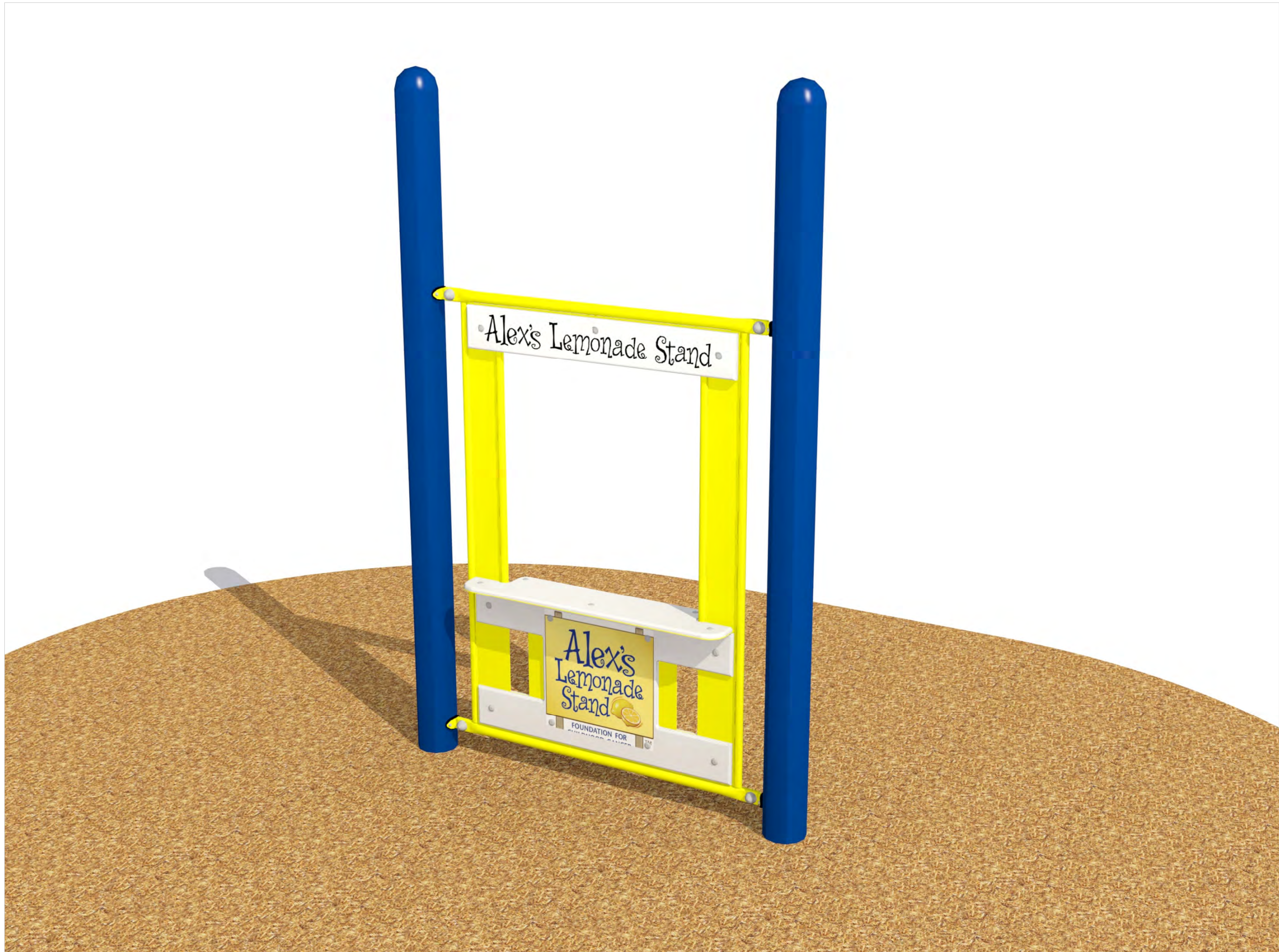

Playworx Playsets, LLC
Jennifer Garcia
2550 Sandy Plains Rd
Suite 225 #348
Marietta, GA

**Town of Golden
Beach
Tweddle Park
Golden Beach, FL
R0321181016**





Playworx Playsets, LLC
Jennifer Garcia
2550 Sandy Plains Rd
Suite 225 #348
Marietta, GA

**Town of Golden
Beach
Tweddle Park
Golden Beach, FL
R0321181016**



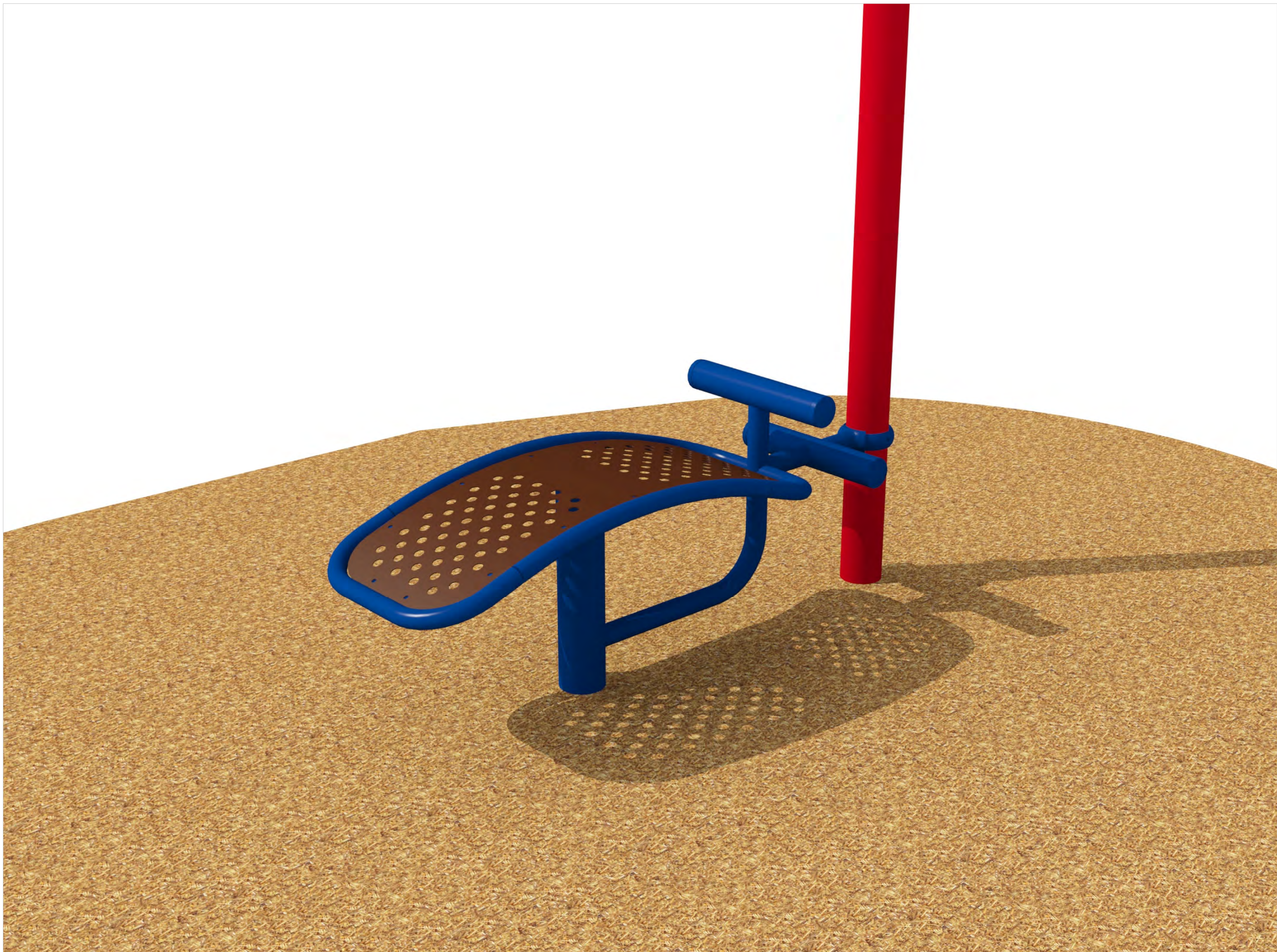

Playworx Playsets, LLC
Jennifer Garcia
2550 Sandy Plains Rd
Suite 225 #348
Marietta, GA

**Town of Golden
Beach
Tweddle Park
Golden Beach, FL
R0321181016**



EXHIBIT C

ShadeFLA

561 NE 79TH ST SUITE 330
MIAMI, FL 33138
(305) 759-7423
marg@shadefla.com
www.shadefla.com



ESTIMATE

ADDRESS

Manager Alex Diaz
Town of Golden Beach
1 Golden Beach Drive
Golden Beach, FL 33160 USA

SHIP TO

Town of Golden Beach
1 Golden Beach Drive
Golden Beach, FL 33160
USA

ESTIMATE # EST-18-1138

DATE 02/13/2018

CUST PO#:

ACTIVITY	QTY	RATE	AMOUNT
Fixed Awning PLAYGROUND CANOPY	1	39,095.53	39,095.53T
Size: (W) 40' X (P) 50' Frame: Schedule 40 Paint: Powdercoat Fabric: Comtex Fabric Color: TBD Cable: 3/8" Galvanized Steel Includes: Design, Manufacturing, Engineering, Installation, Quick Release Removal Excludes: Permit, Electrical, Tree Removal, Poured in Place Repair, Piles			
			Subtotal: 39,095.53
Engineering - In-State Engineering Design and Calculations MPanel Analysis (Florida Seal) Excludes: Site Visit	1	2,168.99	2,168.99
Footers (6) Footers 3.5' X 3.5' X 3.6'	1	5,934.00	5,934.00T

**ShadeFla reserves the right to charge additional costs incurred due to: underground utilities and obstructions encountered, rock and/or tree roots struck during the footer excavation, a high water table level, site access restriction, increased material costs (steel, aluminum, concrete) after the 30-day time limit has elapsed, repair of grass, or tile replacement.

SUBTOTAL 47,198.52
TAX (0%) 0.00
TOTAL **USD 47,198.52**

Accepted By

Accepted Date



ShadeFLA
 561 NE 79TH ST SUITE 330
 MIAMI, FL 33138
 (305) 759-7423
 marg@shadefla.com
 www.shadefla.com



ESTIMATE

ADDRESS

Marie Talley
 Town of Golden Beach
 1 Golden Beach Drive
 Golden Beach, FL 33160 USA

SHIP TO

Marie Talley
 Town of Golden Beach
 1 Golden Beach Drive
 Golden Beach, FL 33160
 USA

ESTIMATE # EST-18-1147

DATE 02/15/2018

CUST PO#:

ACTIVITY	QTY	RATE	AMOUNT
Custom Tension Sail Structure. CUSTOM TENSION SAIL STRUCTURE Size: 40' X 50' Fabric: Alnet Fabric Color: TBD Frame: Schedule 80 Columns and Schedule 40 Cross Beams Paint: Powdercoat Cable: 3/8" MGSS Includes: Design, Manufacturing, Project Management Excludes: Tree Removal, Engineering, Permit, Electrical, Piles, Poured-in-Place OR Repairs, Sales Tax	1	46,942.39	46,942.39T
			Subtotal: 46,942.39
Footers FOOTER (s) (6) 3' X 3' X 5	1	23,097.69	23,097.69T
Shipping Shipping Service Includes: Curbside Delivery	1	899.23	899.23
Installation Installation Services Includes Two Part Installation, Equipment	1	19,218.81	19,218.81

*Please note that SALES TAX is DUE IN FULL with first payment.

ACTIVITY	QTY	RATE	AMOUNT
----------	-----	------	--------

NOTE:

The design of tension structures involves a number of factors that may not be entirely known during the early stages of bidding. The structural design with various loading conditions, site conditions, local code requirements, three-dimensional configurations, and material variables is an iterative process and is not directly scalable from one project to the next. In addition, existing conditions at the site may be discovered at any point between initial concept to construction.

For the above reasons, unless a full design is funded before pricing, the preliminary pricing is based initial assumptions, conditions as known or understood at the time of pricing and possibly an initial preliminary partial design. Final pricing subject to revision based upon the completion of final design and resulting pricing.

**ShadeFla reserves the right to charge additional costs incurred due to: underground utilities and obstructions encountered, rock and/or tree roots struck during the footer excavation, a high water table level, site access restriction, increased material costs (steel, aluminum, concrete) after the 30-day time limit has elapsed, repair of grass, or tile replacement.

SUBTOTAL	90,158.12
TAX (0%)	0.00
TOTAL	USD 90,158.12

Accepted By

Accepted Date



GOLDEN BEACH 40' X 50'



Intellectual Property Notice:
This computer file and the shade canopy design that it includes are the property of Shade FLA and are protected under the State and Federal Law. They are authorized for use by the architect to provide proposed designs only, and cannot be used for any other purpose without the express permission of Shade FLA.