



TOWN OF GOLDEN BEACH

One Golden Beach Drive
Golden Beach, FL 33160

MEMORANDUM

Date: February 16, 2021

To: Honorable Mayor Glenn Singer &
Town Council Members

From: Alexander Diaz,
Town Manager

Item Number:

1

Subject: Resolution No. 2719.21 – Variance Request for 326 South Parkway, Golden Beach, FL 33160 (Seawall encroachment into the waterway)

Recommendation:

It is recommended that the Town Council allow the applicant the opportunity to seek approval of the variance request presented in Resolution No. 2719.21.

Background and History:

Town Code Section 46-81 Extension of seawall into waterways. No part of any seawall, including slabs may extend beyond any lot property line into any waterway in the Town. The piles and cap beam may encroach into the waterway, if approved by the agency having jurisdiction.

The applicant's request is to allow the seawall to encroach into the waterway outside the property line approximately 3' at various locations.

The Building Regulation Advisory Board met February 9, 2021 and recommended approval of the variance request, the motion passed with a Board vote of 2 – 1 (Jerome Hollo-Nay)

Attachments:

- Resolution
- Michael Miller Planning Critique
- Notice of Hearing
- Building Regulation Advisory Board Application
- Copy of resident notification listing
- Summary minutes

Financial Impact: None

TOWN OF GOLDEN BEACH, FLORIDA

RESOLUTION NO. 2719.21

A RESOLUTION OF THE TOWN OF GOLDEN BEACH, FLORIDA, AUTHORIZING AND APPROVING A VARIANCE REQUEST FOR THE PROPERTY LOCATED AT 326 SOUTH PARKWAY, GOLDEN BEACH, FLORIDA 33160 TO PERMIT A SEAWALL TO ENCROACH OUTSIDE THE PROPERTY LINE INTO THE WATERWAY BY APPROXIMATELY 3' IN VARIOUS AREAS. WHEN TOWN CODE SECTION 46-81 DOES NOT PERMIT THE SEAWALL TO ENCROACH.

WHEREAS, the applicant, LCM18 Solutions, Inc. (“the applicant”), filed a Petition for Variances/exceptions, from Section 46-81 – Extension of seawall into waterways. No part of any seawall, including slabs may extend beyond any lot property line into any waterway in the Town. The piles and cap beam may encroach into the waterway, if approved by the agency having jurisdiction.

WHEREAS, the applicant’s request is to allow for the seawall to encroach into the waterway outside the property line by approximately 3’.

WHEREAS, these variances and exceptions are for the property at 326 South Parkway, Golden Beach, FL. 33160 (Golden Beach Sec E, Lot 35, Blk G, as recorded in PB 8-122, of the Public Records of Miami-Dade County, (Folio No. 19-1235-005-0620 (the “Property”) and ;

WHEREAS, the Town’s Building Regulation Advisory Board held an advertised public hearing on the Petition for Variance/Exception and recommended approval of the request for the seawall encroachment, for approval by the Town Council; and,

WHEREAS, a public hearing of the Town Council was advertised and held, as required by law, and all interested parties were given an opportunity to be heard; and

WHEREAS, the Town Council having considered the evidence presented, finds that the Petition of Variance meets the criteria of the applicable codes and ordinances to the extent the application is granted herein.

NOW, THEREFORE, BE IT RESOLVED BY THE TOWN COUNCIL OF THE TOWN OF GOLDEN BEACH, FLORIDA, AS FOLLOWS:

Section 1. Recitals Adopted. Each of the above stated recitals are hereby adopted and confirmed.

Section 2. Approval. The Petition for Variance to permit each of the requested variances/exception is hereby granted.

Section 3. Conditions. The Petition for Exception/Variance as granted is subject to the following conditions:

- (1) Applicant shall record a certified copy of this Resolution in the public records of Miami-Dade County; and the construction shall be completed substantially in accordance with those certain plan pages by John H. Omslaer, Professional Engineer, pages numbered 1 through 6, seal dated 08/01/2020, and the Sketch of Boundary Survey, prepared by Clyde McNeal PSM 2883, FL Licensed Surveyor and Mapper, dated 7/13/2020, for the property located at 326 South Parkway, Golden Beach, FL. 33160

Section 4. Implementation. That the Building and Zoning Director is hereby directed to make the necessary notations upon the maps and records of the Town of Golden Beach Building and Zoning Department and to issue all permits in accordance with the terms and conditions of this Resolution. A copy of this Resolution shall be attached to the building permit application documents.

Section 5. Effective Date. This Resolution shall be effective immediately upon adoption.

Sponsored by Administration.

The Motion to adopt the foregoing Resolution was offered by _____, seconded by _____ and on roll call the following vote ensued:

Mayor Glenn Singer	_____
Vice Mayor Bernard Einstein	_____
Councilmember Judy Lusskin	_____
Councilmember Jaime Mendal	_____
Councilmember Kenneth Bernstein	_____

PASSED AND ADOPTED by the Town Council of the Town of Golden Beach, Florida, this 16th of February, 2021.

ATTEST:

MAYOR GLENN SINGER

LISSETTE PEREZ
TOWN CLERK

APPROVED AS TO FORM
AND LEGAL SUFFICIENCY:

STEPHEN J. HELFMAN
TOWN ATTORNEY

**TOWN OF GOLDEN BEACH
COMMUNITY DEVELOPMENT
MEMORANDUM**

To: Building Regulatory Advisory Board
Town of Golden Beach

From: Michael J. Miller, AICP *MJM*
Consultant Village Planner

Date: January 5th, 2021

Subject: Zoning Variance Application
Request to Keep Existing Seawall that Encroaches into Grand Canal
326 South Parkway
Lots 35 of Block G, Section E
MMPA Project No.04-0101-0524

ISSUE

In September 2020, Bill Thomas / Southeast Marine Construction, as agent for the current property owner, LCM 18 Solutions, LLC (Leon Mochon), submitted a request to the Town to renovate the existing seawall by installing a footer, adding batter piles, and installing a new larger seawall cap overpour and small dock at the above site. The new owner acquired the site in August 2019 and executed the Town's normal disclosure / acknowledgement forms concerning older seawalls. The owner did not proceed within the required Code timeframe to prepare an inspection report on the existing seawall and/or file permits to remove / replace / repair deficiencies for the nonconforming seawall. Town Code Section 46-81 states that if renovations occur to an existing seawall that has deficiencies or is located seaward of the rear property line it must be corrected - unless a variance is granted by the Town. During the initial Town plan review it was noticed that the existing vertical seawall itself was built seaward of the rear property line encroaching into the Grand Canal by several feet (2'-3'+/-). The lot's waterfront property line is curved slightly into the lot. Installing a curved seawall section is more difficult than installing a straight seawall section - it appears the marine contractor who built the existing seawall simply built a straight seawall section. The Town's staff at the time the existing seawall was built apparently did not notice the encroachment (visually or by as-built survey) and/or allowed it to remain. During the Town's initial review in September 2020, it was determined by the Town's Administration that the owner had to file / obtain a variance to keep the seawall where it is built in accordance with the applicable Code provisions and the owner was advised of this determination. In general, the new seawall renovation plans will comply with the Town's / M-D RER regulations. In late December 2020, the owner filed a formal variance application. The variance will be presented to the BRAB with the BRAB application for the proposed seawall improvements. MMPA was requested to review the variance application and prepare our typical staff report for consideration by the Town BRAB / Town Council.

**Town of Golden Beach
Zoning Variance Application
326 South Parkway
Request to Keep Existing Seawall that Encroaches into Grand Canal
January 5th, 2020
Page 2**

Following is the specific variance request:

- Variance from Sec. 46-81 - Extension of seawall into waterways.

No part of any seawall, including slabs may extend beyond any lot property line into any waterway in the Town. The piles and cap beam may encroach into the waterway, if approved by the agency having jurisdiction. If during the construction of a new seawall or renovation of an existing seawall it is found that portions of the existing seawall encroach into a public waterway adjoining a lot, those portions of the seawall encroachment shall be modified or removed, unless a Variance is granted by the Town. See section 46-86 below for the definition of legal nonconformity, and requirements for modification, removal, and compliance with the new standards.

ANALYSIS

As per the Town's request MMPA has completed our review of the above referenced variance application and provide the following comments for consideration:

Variance to Sec. 46-81 - The application form submitted requests a variance from Town Code Section 46-81 to allow the existing vertical seawall that encroaches several feet (2'-3'+/-) into the adjoining Grand Canal can remain in its current location. The applicant stated they purchased the property with the existing condition. As stated above the new owner acquired the site in August 2019 and executed the Town's normal disclosure / acknowledgement forms concerning older seawalls. The owner did not proceed within the required Code timeframe to prepare an inspection report of the existing seawall and/or file permits to remove / replace / repair the deficient nonconforming seawall. The plans submitted show the applicant is proposing the keep the existing seawall where it is currently built and reinforce it / add a new extended seawall cap / add a concrete small dock. The current nonconforming wood dock will be removed (it violates the 10' side setback requirement). The lot is a narrow pie-shaped lot with the narrowest portion of the lot fronting on the Grand Canal that is only 45' in width. Although the applicant's survey does not show specific dimensions of the existing seawall encroachment MMPA scaled the drawings and found the encroachment is from 6"+/- at the lot corners to about 2'-3' at its furthest encroachment.

The applicant appears to have not presented this request to Miami-Dade RER as yet, as there are no preliminary RER review stamps on any of the plans. Based on our experience we believe RER would not object to this request for the seawall / dock improvements.

NON-USE VARIANCE JUSTIFICATION

The comments below are based on the applicants request for a variance to Section 46-81.

The variance requested is for relief from the provisions of the Town Code (list sections).

The applicant seeks relief from Section 46-81 of the Town's Code of Ordinances, which states "No part of any seawall, including slabs may extend beyond any lot property line into any waterway in the Town. The piles and cap beam may encroach into the

**Town of Golden Beach
Zoning Variance Application
326 South Parkway
Request to Keep Existing Seawall that Encroaches into Grand Canal
January 5th, 2020
Page 3**

waterway, if approved by the agency having jurisdiction. If during the construction of a new seawall or renovation of an existing seawall it is found that portions of the existing seawall encroach into a public waterway adjoining a lot, those portions of the seawall encroachment shall be modified or removed, unless a Variance is granted by the Town. See section 46-86 below for the definition of legal nonconformity, and requirements for modification, removal, and compliance with the new standards”.

The applicant states “Town Code Section 46-81 to allow existing seawall to expand 3’ for wet face of seawall from e”.

- 1) *To recommend the granting of the variance, it must meet all the following criteria.*
- a. *The Variance is in fact a Variance from a zoning regulation as set forth within the Zoning Chapter of the Town Code.*

The applicant states: “Yes Confirmed” MMPA agrees that the variance requested is valid to provide relief from the normal Zoning Code requirements.

- b. *Special conditions and circumstances exist which are peculiar to the land or structure involved, and which are not applicable to other lands or structures in the same district.*

The applicant states: “Yes. The existing seawall was installed approximately 3’ from the property line prior to the property being purchased by the current property owner”. MMPA believes the applicant did not adequately address the Code requirement by providing any evidence that there are special conditions or circumstances peculiar to this lot and not applicable to other similar lands. The Town’s Code provision are written specifically to address just type of situation and require corrections to past improper construction activities. Without such a Code provision, contractors / owners could think they can build improvements that violate Code provisions, and they are not held responsible when they sell real estate, and/or future owners are not responsible for corrections made by previous owners. That is what real estate attorneys / surveyors / title companies are for at closings – to identify issues in the title exceptions. That is why the Town requires the seawall affidavit. In our opinion acquiring a site with a known deficiency is not a special condition or circumstance. A variance procedure is included in the Town’s Code to allow discretion for individual situations like this.

- c. *The special conditions and circumstances do not result from the actions of the applicant.*

The applicant states: “Correct – The seawall was installed prior to when the applicant purchased the property”. See the above MMPA response. The owner was made aware of the seawall encroachment prior to acquiring the site and signed the Town’s acknowledgement forms in 2019 when the site was purchased. The Town’s current regulatory system is meant to identify past problems and require corrections.

- d. Granting the variance requested will not confer on the applicant any special privilege that is denied by the Zoning Chapter of the Town Code to other lands or structures in the same district.*

The applicant states: "Correct – the existing enlarged seawall was installed by a previous owner and removing and replacing the wall along the property line would create a significant financial burden to the current property owner". See the above MMPA response. The owner was made aware of the seawall encroachment prior to acquiring the site and signed the Town's acknowledgement forms in 2019 when the site was purchased. The Town's current regulatory system is meant to identify past problems and require corrections. Based on the Code requirements in Sec. 46-81 the Town has required some property owners remove illegal seawalls and other marine structures. Allowing the existing encroaching seawall to remain could be construed as conferring a special privilege to this owner.

- 2. Literal interpretations of the provisions of the Zoning Chapter of the Town Code would deprive the applicant of rights commonly enjoyed by other properties in the same district under the terms of zoning regulations and would work unnecessary and undue hardship on the applicant.*

The applicant states: "Correct – the safe mooring of a vessel, and the ingress / egress by owner for seawall improvements". See the above MMPA response. In our opinion no deprivation of rights commonly enjoyed by others would occur. In our opinion, there is no undue hardship – a seawall was built on public land (waterway) and the Code requires that it be relocated unless a variance is granted. The cost of compliance is not considered a hardship. The lot is the same shape and size as many others that comply in the Town. According to the application form the owner will apparently spend \$67,000 to renovate the existing seawall. The cost to remove the encroaching seawall and build a new one in the right location would be about the same. The owner was made aware of the seawall encroachment prior to acquiring the site and signed the Town's acknowledgement forms in 2019 when the site was purchased. The Town's current regulatory system is meant to identify past problems and require corrections. Based on the Code requirements in Sec. 46-81 the Town has required some property owners remove nonconforming seawalls and other marine structures. The safe mooring of a vessel to the existing seawall or relocated seawall is assured and no ingress / egress is affected.

- 3. The variance granted is the minimum Variance that will make possible the reasonable use of the land or structure.*

The applicant states: "Yes – the property owner is requesting an after the fact approval 3' waterward of the property line prior to purchase of property". The existing seawall encroachment has existed for some time (date of construction unknown). The encroachment is fairly minimal (6" - 3'+/). There does not appear to be any impediment related to vessel navigation. See above MMPA response.

**Town of Golden Beach
Zoning Variance Application
326 South Parkway
Request to Keep Existing Seawall that Encroaches into Grand Canal
January 5th, 2020
Page 5**

- 4. The granting of the variance will be in harmony with the general intent and purpose of the Town Code and the Variance will not be injurious to the area involved or otherwise detrimental to the public welfare.*

The applicant states: "Correct – no navigational impacts and matches the style and design of neighboring properties". See above MMPA response. No evidence was provided verifying the encroaching seawall next to this lot exists on neighboring sites. In fact, the survey provided by the applicant shows the adjoining seawalls appear to comply with Town Code locations (within the lots). MMPA agrees there would be little or no navigational impacts.

SUMMARY

In September 2020, a marine contractor, as agent for the current property owner, LCM 18 Solutions, LLC (Leon Mochon), submitted a request to the Town to renovate the existing seawall by installing a footer, batter piles, a new larger seawall cap overpour, and small dock at the above site. The new owner acquired the site in August 2019 and executed the Town's normal disclosure / acknowledgement forms concerning older seawalls. The owner did not proceed within the required Code timeframe to either prepare an inspection report on the existing seawall and/or file permits to remove / replace / repair deficiencies for the nonconforming seawall. Town Code Section 46-81 states that if renovations occur to an existing seawall that has deficiencies or is located seaward of the rear property line it must be corrected - unless a variance is granted. During the initial Town plan review it was noticed that the existing vertical seawall itself was built seaward of the rear property line encroaching into the Grand Canal by several feet (2'-3'+/-). It was determined by the Town's Administration that the owner had to file / obtain a variance to keep the seawall where it is built in accordance with the applicable Code provisions and the owner was advised of this determination. In late December 2020, the owner filed a formal variance application. The variance will be presented to the BRAB with the application for the proposed seawall improvements. MMPA was requested to review the variance application and prepare our staff report for consideration.

MMPA has reviewed the requested non-use variance which, if granted, would allow the existing nonconforming seawall that was built several feet into the Grand Canal to remain in its current location as required by Sec. 46-81. The owner is also requesting permission to reinforce / improve the existing seawall by allowing new support structures (footer / batter piles / seawall cap). The BRAB will consider those separately. The encroachment ranges from about 6" to 3'.

MMPA believes the Town's Code provisions in Section 46-81 are written specifically to address just type of situation and require corrections to past improper construction activities. Without such a Code provision, contractors / owners could think they can build improvements that violate Code provisions, and they are not held responsible when they sell the real estate, and/or future owners are not responsible for corrections made by previous owners. That is what real estate attorneys / surveyors / title companies are for at closings – to identify issues. A variance procedure is included in the Code to allow the Town discretion for individual situations like this.

Overall MMPA believes the existing seawall encroachment is minimal but it does not comply with the Code provision that requires the vertical seawall to be on the owner's land. Given the amount of encroachment MMPA believes it not an unreasonable request.



TOWN OF GOLDEN BEACH NOTICE OF PUBLIC HEARING

The **BUILDING ADVISORY BOARD** and the **TOWN COUNCIL** of the **TOWN OF GOLDEN BEACH** will hold a Public hearing on the following proposal:

 X Variance Request(s)
 X Accessory Structures

Construction of a dock and seawall improvements.

Relief from Town Code Sec. 46-81. - Extension of seawall into waterways.

No part of any seawall, including slabs may extend beyond any lot property line into any waterway in the Town. The piles and cap beam may encroach into the waterway, if approved by the agency having jurisdiction.

Request is to allow the seawall to encroach into the waterway outside of the property line approximately 3'

JOB ADDRESS: 326 South Parkway, Golden Beach, FL,
OWNER ADDRESS: 326 South Parkway, Golden Beach, FL.
REQUESTED BY: LCM18 Solutions, Inc.
LEGAL DESCRIPTION: Lot 35, Block G, GB Sect E, PB 8-122
FOLIO NO.: 19-1235-005-0620

The **BUILDING ADVISORY BOARD** will consider this item:

GOLDEN BEACH TOWN HALL
1 GOLDEN BEACH DR., GOLDEN BEACH, FL.
February 9, 2021 at 6pm – (via zoom):
<https://us02web.zoom.us/j/89291108015?pwd=NS8rVWpJhN21mSUo1cmFadhEre3yZz09>
Meeting ID: 892 9110 8015
Passcode: 752288

The **TOWN COUNCIL** will consider this item:

GOLDEN BEACH TOWN HALL
1 GOLDEN BEACH DR., GOLDEN BEACH, FL.
February 16, 2021 at 5pm - (via zoom):
<https://us02web.zoom.us/j/87800127191?pwd=b1FSS1JiNytEaGRxbXM4UjJlNNkZSZz09>
Meeting ID: 878 0012 7191
Passcode: 834667

If you wish to submit written comments for consideration, they should be submitted to the Office of the Golden Beach Town Manager, prior to the scheduled meeting. If you have any questions regarding the proposed action, you may contact the Building Department at (305) 932-0744

DATED: January 27, 2021

Linda Epperson – Director Building & Zoning

PURSUANT TO FLA. STATUTE 286.0105, THE TOWN HEREBY ADVISES THE PUBLIC THAT: IF A PERSON DECIDES TO APPEAL ANY DECISION MADE BY THE COUNCIL, BOARD OR COMMITTEE WITH RESPECT TO ANY MATTER CONSIDERED AT ITS MEETING OR HEARING, HE WILL NEED A RECORD OF THE PROCEEDINGS, AND THAT FOR SUCH PURPOSE, AFFECTED PERSONS MAY NEED TO ENSURE THAT A VERBATIM RECORD OF THE PROCEEDING IS MADE, WHICH RECORD INCLUDES THE TESTIMONY AND EVIDENCE UPON WHICH THE APPEAL IS TO BE BASED. ANY INDIVIDUAL WHO BELIEVES HE OR SHE HAS A DISABILITY WHICH REQUIRES A REASONABLE ACCOMMODATION IN ORDER TO PARTICIPATE FULLY AND EFFECTIVELY IN A MEETING OF THE BUILDING REGULATION BOARD MUST SO NOTIFY THE TOWN CLERK, AT (305) 932-0744 AT LEAST 24 HOURS PRIOR TO THE DATE OF THE MEETING

326 SPANKEY VARIANCE REQUEST FOR SEAWALL
 TOWN OF GOLDEN BEACH
 APPLICATION FOR
 BUILDING REGULATION ADVISORY BOARD HEARING

Applicant check here	Complete application, sign, and notarize.	Bldg Dept Use
<input type="checkbox"/>	If a zoning variance is applied for, the petition for variance, pages 9, 10 and 11 shall be submitted with the application and shall include: <ol style="list-style-type: none"> a. Property Legal Description b. Property Folio number c. Street address d. Owners of record e. Owner and agent names and signatures properly notarized. 	
<input type="checkbox"/>	Initial submittal as directed on page one; surveys, building plans, Warranty Deeds, and applications. After Zoning approval is issued completed sets are to be submitted 8 days prior to the meeting date as follows: Seven (7) copies no larger than 11" x 17" & 1 original full size sealed set 24" x 26". The same amount of copies are required for a variance. Each completed package shall consist of 1 each of an application, survey, Warranty Deed and building plans. Submit 1 CD with all documents included	
<input type="checkbox"/>	Conceptual construction drawings prepared and signed by a licensed design professional that shall include, at a minimum, the following: <ol style="list-style-type: none"> a. Site plan at a scale not less than 1/8" = 1'-0" (Include grade elevations) b. Proposed Floor Plan views, at a scale not less than 1/4" = 1'-0" c. Cross and longitudinal sections preferably through vaulted areas, if any. d. Typical exterior wall cross section. e. Full elevations showing flat roof and roof ridge height and any other higher projections. f. Sample board of construction materials to be used. g. Existing and proposed ground floor elevations (NGVD). h. Grading & Drainage Calculations i. Zone 3 Properties: Affidavit of Seawall Conformity 	
<input type="checkbox"/>	Landscaping Plan, separate from building plan package, prepared and signed by a licensed landscape design professional: The same amount of copies as outlined in the Building plan submittal. Each completed package shall consist of 1 each of an application, existing landscape survey, Warranty Deed, landscape plans with building site plans. Mark CD accordingly (separate from building)	
<input type="checkbox"/>	First Floor and Second Floor area calculations marking the geometrical areas used to calculate the overall floor areas.	
<input type="checkbox"/>	Colored rendering showing new construction or proposed addition. Marked with the applicable address.	
<input type="checkbox"/>	Estimated cost of proposed work. For additions/remodels fair market value of property showing land value and structure value separately.	
<input type="checkbox"/>	Site plan detailing construction site personnel parking.	

TOWN OF GOLDEN BEACH
APPLICATION FOR
BUILDING REGULATION ADVISORY BOARD HEARING

Application fee: _____

Request hearing in reference to:

New residence/addition: _____ Variance(s): _____
Exterior alterations: New toe wall footer, seawall cap whi Other Structure: _____
Date application filed: _____ For hearing date: _____

1. Project information:

Project description: Intal 45' of footer, 6 batter piles, 45' new seawall cap and 3'

Legal Description: Golden Beach Sec E PB 8-122 LOT 35 BLK G Lot size 59.86 x 175

Folio #: 19-1235-005-0620

Address of Property: 326 South Parkway

2. Is a variance(s) required: Yes No How Many? _____
(If yes, please submit variance application form for each request).

Owner's Name: LCM 18 Solutions LLC Phone 786-606-6030 Fax _____

Owner's address: 326 South Parkway City/State Golden Beach Zip 33160

Email address: mochonleon@gmail.com

Agent: Bill Thomas Phone 954-532-0129 Fax _____

Agent's address: 902 NE 1 Street #2 City/State Pompano beach Zip 33060

Email address: Williamr@unlimitedps.net

Architect: _____ Phone _____ Fax _____

Email address: _____

Contractor: Southeast Marine Constructio Phone 954-630-2300 Fax _____

3. Describe project and/ or reason for hearing request: Install new toe wall footer new batter piles and seawall cap and new 65 square foot concrete dock

4. The following information is submitted for assisting in review:

Building Plans:

Conceptual: Preliminary: Final:
Other: _____

5. Estimated cost of work: \$\$\$67,000.00
Estimated market value of: Land \$ _____
Building \$ _____

(Note: If estimated cost of work is 40% of the market value of the building an independent appraisal is required).

TOWN OF GOLDEN BEACH
APPLICATION FOR
BUILDING REGULATION ADVISORY BOARD HEARING

6. Is hearing being requested as a result of a Notice of Violation? no
7. Are there any structures on the property that will be demolished? no
8. Does legal description conform to plat? no
9. Owner Certification: I hereby certify that I am the owner of record (*) of the property described in this application and that all information supplied herein is true and correct to the best of my knowledge.

Signature of owner(s): [Signature]

Acknowledged before me this 18 day of 20 December

Type of identification: Mexican driver's license [Signature]
Notary Public

Owner/Power of Attorney Affidavit:

I, being duly sworn, depose and say I am the owner (*) of the property described in this application and that I am aware of the nature and request for: waterfront improvements relative to my property and I am hereby authorizing _____ to be my legal representative before the Building Regulation Advisory Board and Town Council.

[Signature] Signature of owner(s)
Acknowledged before me this 18 day of December 20²⁰

Type of identification: Mexican driver's license [Signature]
Notary Public

(*) If owner of record is a corporation then the president with corporate seal, the president and the secretary (without corporate seal), or duly authorized agent for the corporation may execute the application, proof that the corporation is a corporation in good standing.

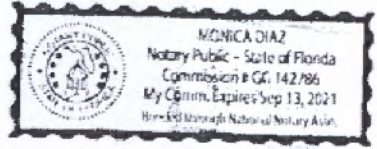

TOWN OF GOLDEN BEACH
APPLICATION FOR
BUILDING REGULATION ADVISORY BOARD HEARING

Property Address: 326 South Parkway
Legal Description: Golden Beach Sec E PB 8-122 Lot 35 BLK G
Owner's Name: LCM 18 Solutions LLC Phone 786-606-6030 Fax _____
Agent's Name: Bill Thomas Phone 954-532-0129 Fax _____
Board Meeting of: _____

- NOTE: 1. **Incomplete applications will not be processed.**
2. Applicant and/or architect must be present at meeting.

Application for: Install New toe wall footer, new concrete seawall cap whit batter piles and
Lot size: 59.860 X 175
Lot area: 10,475.5 Sq. Ft
Frontage: _____
Construction Zone: Over- water
Front setback: _____
Side setback: _____
Rear setback: _____
Coastal Construction: Yes No East of coastal const. control line: Yes No
State Road A1A frontage: _____
Swimming pool: Yes No Existing: no Proposed: _____
Fence Type: _____ Existing: no Proposed: _____
Finished Floor elevation N.G.V.D.: _____
Seawall: _____ Existing: _____ Proposed: _____
Lot Drainage: _____
How will rainwater be disposed of on site? _____

Adjacent use (s): _____
Impervious area: _____
% of impervious area: _____
Existing ground floor livable area square footage: _____
Proposed ground floor livable area square footage: _____
Existing 2nd floor livable area square footage: _____
Proposed 2nd floor livable area square footage: _____
Proposed % of 2nd floor over ground floor: _____
Vaulted area square footage: _____
Vaulted height: _____
Color of main structure: _____
Color of trim: _____
Color & material of roof: _____
Building height (above finished floor elevation): _____
Swale: (Mandatory 10'-0" from edge of payment, 10 ft. wide x 1 ft. deep minimum): _____

Existing trees in Lot: _____ in Swale: _____
Proposed trees in Lot: _____ in Swale: _____
Number & type of shrubs: _____
Garage Type: _____ Existing: _____ Proposed: _____
Driveway width & type: _____

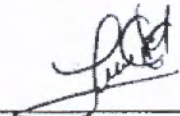
Signature of Applicant:  Date: _____

TOWN OF GOLDEN BEACH
BUILDING REGULATION ADVISORY BOARD
APPLICATION FOR
PETITION FOR VARIANCE

Date: _____

Fee: _____

I, Mr, Leon Mochon hereby petition the Town of Golden Beach for a variance from the terms of the Town of Golden Beach Code of Ordinances affecting property located at: 326 South Parkway Folio No. 19-1235-005-0620

As specified in the attached "Application for Building Regulation Advisory Board" and related supporting material.

1. The Variance requested is for relief from the provisions of (list section number(s) of the Town of Golden Beach Code of Ordinances): Town Code section 46-81 to allow existing seawall to expand 3' for wet face of seawall from

2. In order to recommend the granting of the variance, it must meet all the following criteria (please provide a response to each item):

a. The Variance is in fact a Variance from a zoning regulation as set forth within the Zoning Chapter of the Town Code. Yes. Confirmed

b. Special conditions and circumstances exist which are peculiar to the land or structure involved, and which are not applicable to other lands or structures in the same district. Yes, The existing seawall was installed approximately 3' from the property line prior to the property being purchasad by the current prope

c. The special conditions and circumstances do not result from the actions of the applicant. Correct. The seawall was installed prior to when the applicant pur

d. Granting the Variance requested will not confer on the applicant any special privilege that is denied by the Zoning Chapter of the Town Code to other lands or structures in the same district. Correct. the existing enlarged seawall was installed and removing and replacing the wall along the property line would create a significant financial burden to the current property owner.

BY A PREVIOUS OWNER

TOWN OF GOLDEN BEACH
BUILDING REGULATION ADVISORY BOARD
PETITION FOR VARIANCE

3. Literal interpretations of the provisions of the Zoning Chapter of the Town Code would deprive the applicant of rights commonly enjoyed by other properties in the same district under the terms of zoning regulations and would work unnecessary and undue hardship on the applicant. Correct, the safe mooring of a vessel, and the ingress, egress by seawall improvements
4. The Variance granted is the minimum Variance that will make possible the reasonable use of the land or structure. Yes, the property owner is requesting an after the fact a 3' waterward of the property line prior to purchase of property
5. The granting of the Variance will be in harmony with the general intent and purpose of the Town Code and the Variance will not be injurious to the area involved or otherwise detrimental to the public welfare. Correct, no navigational impacts and matches the s and design of neighboring properties.

Does the Variance being requested comply with all the above listed criteria?
 Yes No

6. Our code states that submission of a written statement is invited and encouraged. Has the applicant (petitioner) explained the variance to the owners of the nearest adjacent residences and sought their approval in writing? Yes No.
Please attach any written letters of no objection to this petition.

7. Is this request related to new construction? Yes No

8. Is construction in progress? NO

9. Is this request as a result of a code violation? YES THE TOWN IS REQUIRING APPROVAL FOR THE EXISTING CHANGED SEAWALL

10. Did this condition exist at the time property was acquired? Yes No

11. Is this request sought as a remedy to a case to be heard, or action taken by the Special Magistrate? NO

12. Do you have a building permit? Yes No

Building Permit No. _____ Date issued: _____

TOWN OF GOLDEN BEACH
BUILDING REGULATION ADVISORY BOARD
PETITION FOR VARIANCE
AFFIDAVIT BY OWNER

Affidavit by Owner for Variance Request(s):

Folio No.: 19-1235-005-0620 Address: 326 South Parkway

Legal Description: Golden Beach SEC E PB 8-122

Being duly sworn, deposes and says: That He/She is the Owner named in the application for Building Advisory Board for the hearing date of _____ relating to Variance requests for construction or other work to be performed on, or in connection with, the premises located as indicated in the application.

I acknowledge notification by The Town of Golden Beach, that granting of a variance(s) by The Town Council, is conditioned on the following:

1. That a Building Permit for the contemplated work pursuant to the Variance must be issued within two (2) years from the date of the approval of the Resolution granting such variance request.
2. If a Building Permit is not issued within the two (2) year time limit set then the Resolution granting the Variance approval will be null and void.
3. That as the applicant, and at my own expense, I shall record a certified copy of the Resolution in the public records of Miami-Dade County and return two (2) certified copies to the Golden Beach Town Hall for inclusion into my property records.

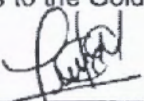

Signature of Owner or Legal Representative

Sworn to and subscribed before me this 18 day of December 2020.

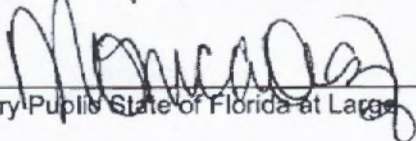

Notary Public State of Florida at Large

Personally know to me Produced Identification

Mexican driver license



TOWN OF GOLDEN BEACH
ACKNOWLEDGEMENT and AFFIDAVIT BY OWNER
Chapter 46-85 Height of Seawalls and Docks and Extension of Deck of Dock.
of the Code of Ordinances
Article IV Seawalls and Docks.

Affidavit by Owner: LEON MOCHON

Folio No.: 19-1235-005-0620 Address: 326 SOUTH PARKWAY

Legal Description: GOLDEN BEACH SEC-E PB 8-122

LOT 35 BLK G 59.860 X 175.

Being duly sworn, deposes and says: That He/She is the Owner named in the permit application for construction or other related work to be performed on, or in connection with, the premises, as indicated above, and is in agreement that granting of a permit for construction on said premises, agrees to repair, or replace said seawall in question, to a conforming minimum 3.425 feet above NAVD-88 or to a maximum 4.425 feet NAVD-88 elevation and to replace/and or repair any deteriorated seawall or portion thereof, as required by the Town's Code of Ordinances, Article IV "Seawalls and Docks, The Miami Dade County DERM Division, State of Florida DEP Coastal Division, the Army Corp of Engineers (if applicable) and the current Florida Building Code.



Signature of Owner or Legal Representative
Print Name: LEON MOCHON

Sworn to and subscribed before me this 18 day of DEC 2020.

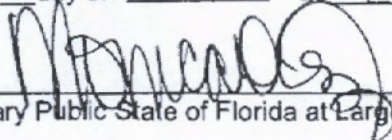

Notary Public State of Florida at Large

Personally know to me

Produced Identification
Mexican Drivers license

See attached survey supplied by owner
for exact property information.

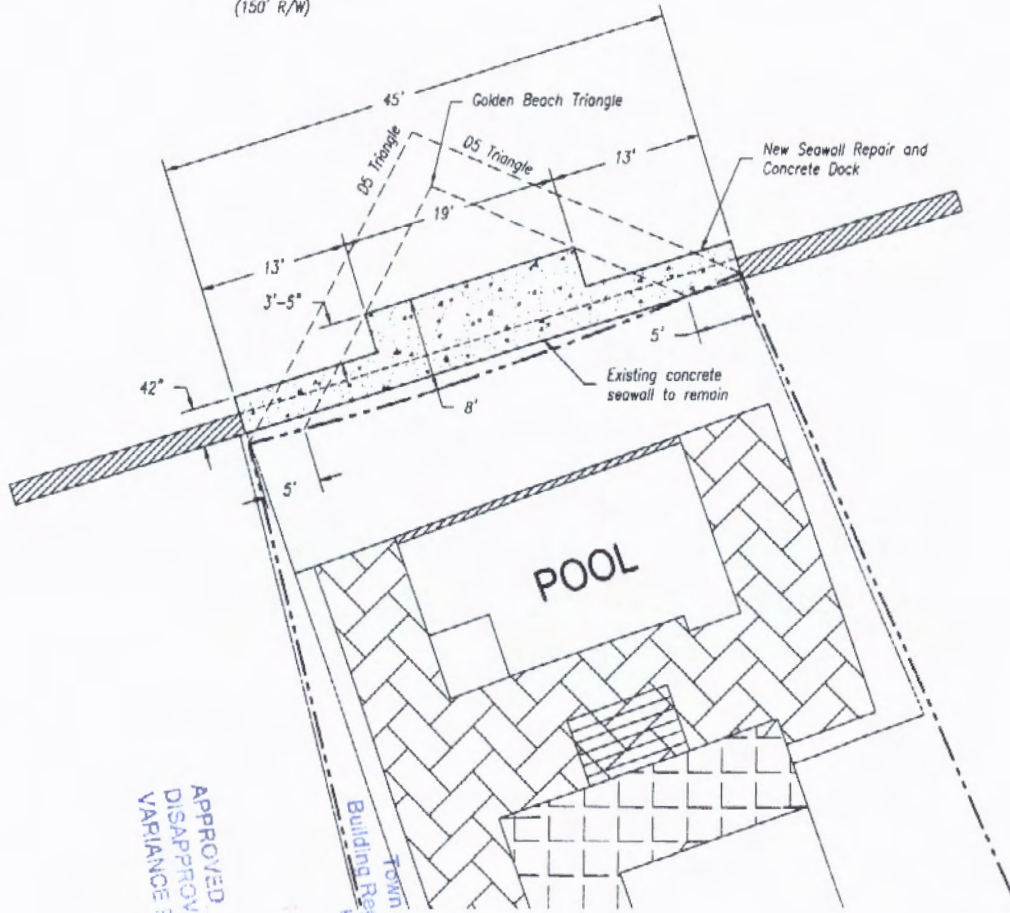
CANAL
(150' R/W)



Site Plan
(Proposed Conditions)
Scale: 1" = 10'

Legal Description

Lot 35 Block G

GOLDEN BEACH SEC E

Plat Book B Page 122

Dade County

Florida

RER - NATURAL RESOURCES DIVISION
PRELIMINARY APPROVAL
NAME Micaela Soldi
DATE 09/02/2020

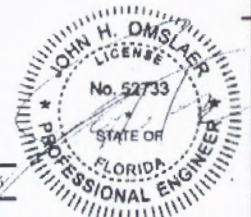

APPROVED
DISAPPROVED
VARIANCE REQ.

Town of Golden Beach
Building Regulatory Advisory
Meeting Date

Sheet 2 of 6

PREPARED FOR
SOUTHEAST MARINE CONST. INC
1121 NW 51 Court
Ft. Lauderdale, FL 33309
(954) 630-2300

Project:
Proposed Dock/Seawall Repair
LCM18 Solutions LLC
326 S Parkway
Golden Beach, Florida 33160

JOHN OMSLAER, P.E.
E.D. #26829 | LICENSE #52733
DYNAMIC ENGINEERING SOLUTIONS INC
351 S CYPRESS RD, SUITE #303
Pompano Beach, Florida 33060
OFFICE (954) 545-1740

CANAL
(150' R/W)

See attached survey supplied by owner for exact property information.

NOTE:
(3) Existing wood dock piles and (2) existing concrete piles to be removed, existing unauthorized brick pavers to be removed

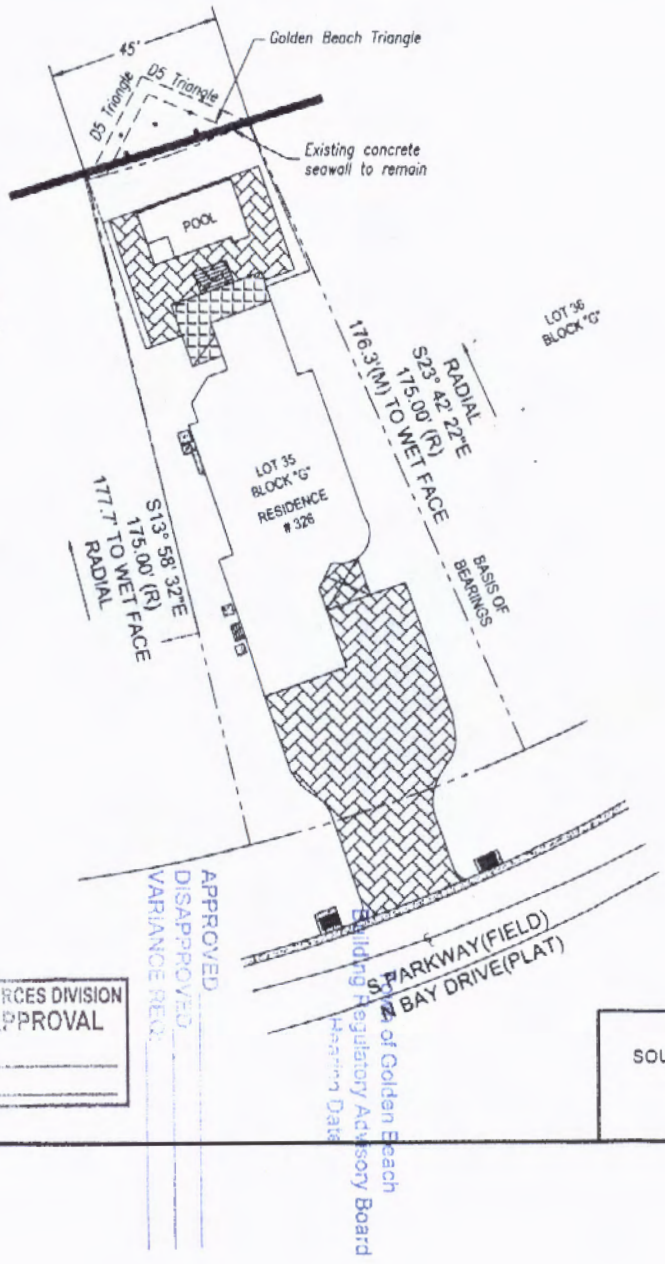

Location Map

Site Plan
(Existing Conditions)
Scale: 1" = 30'

Legal Description
Lot 35 Block G
GOLDEN BEACH SEC E
Plat Book 8 Page 122
Dade County
Florida

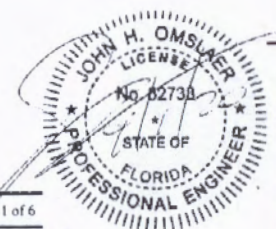

RER - NATURAL RESOURCES DIVISION
PRELIMINARY APPROVAL
NAME Micaela Soldi
DATE 09/02/2020

PREPARED FOR
SOUTHEAST MARINE CONST. INC
1121 NW 51 Court
Ft. Lauderdale, FL 33309
(954) 630-2300

Project:
Proposed Dock/Seawall Repair
LCM18 Solutions LLC
326 S Parkway
Golden Beach, Florida 33160

Sheet 1 of 6
JOHN OMSLAER, P.E.
E. B. #26829 / LICENSE #82733
DYNAMIC ENGINEERING SOLUTIONS INC
251 S. CYPRESS RD. SUITE #203
POMPANO BEACH, FLORIDA 33069
OFFICE (954) 545-1740

Building Department of Golden Beach
 Regulatory Advisory Board
 Hearing Date

APPROVED
 DISAPPROVED
 VARIANCE REQ.



AERIAL PHOTOGRAPH (NOT-TO-SCALE)



SCALE: 1" = 30'

SURVEYOR NOTES

- DRIVEWAY CROSSES THE BOUNDARY LINE ON SOUTHERLY SIDE OF LOT AS SHOWN.
- FENCES LIE NEAR BOUNDARY LINES AS SHOWN, OWNERSHIP NOT DETERMINED.
- FENCES CROSS THE BOUNDARY LINES ON NORTHERLY AND WESTERLY SIDES OF LOT AS SHOWN.

REVISIONS

- ON 07/13/2020 ADDED SEAWALL TOPOGRAPHY (L.C.)

LEGEND:

- A/C -AIR CONDITIONER
- AL -ARC LENGTH
- (C) -CALCULATED
- D.E -DRAINAGE EASEMENT
- (M) -MEASURED
- P.O.B -POINT OF BEGINNING
- P.O.C -POINT OF COMMENCING
- P.B -PLAT BOOK
- P.G -PAGE
- P.U.E -PUBLIC UTILITY EASEMENT
- R -RADIUS
- (R) -RECORD
- U.E -UTILITY EASEMENT
- WM -WATER METER
- FF -FINISH FLOOR
- O.R.B -OFFICIAL RECORD BOOK
- ELEV -ELEVATION
- FENCE
- # -NUMBER
- ASPHALT
- CONCRETE
- PAVER/BRICK
- WOOD
- LIGHT POLE
- WELL
- WATER VALVE
- CENTER LINE
- CATCH BASIN
- FIRE HYDRANT
- POLE
- MANHOLE
- TOPOGRAPHIC ELEVATION

GENERAL NOTES:

- 1) THIS SURVEY IS BASED UPON RECORD INFORMATION BY CLIENT. NO SPECIFIC SEARCH OF THE PUBLIC RECORD HAS BEEN MADE BY THIS OFFICE UNLESS OTHERWISE NOTED.
- 2) IF THIS SURVEY HAS BEEN PREPARED FOR THE PURPOSES OF A MORTGAGE TRANSACTION, ITS SCOPE IS LIMITED TO THE DETERMINATION OF TITLE DEFICIENCIES. NO FUTURE CONSTRUCTION SHALL BE BASED UPON THIS SURVEY WITHOUT FIRST OBTAINING APPROVAL AND/OR UPDATES FROM NEXGEN SURVEYING, LLC. NEXGEN SURVEYING, LLC, ASSUMES NO RESPONSIBILITY FOR ERRORS RESULTING FROM FAILURE TO ADHERE TO THIS CLAUSE.
- 3) ANY FENCES SHOWN HEREON ARE ILLUSTRATIVE OF THEIR GENERAL POSITION ONLY. FENCE TIES SHOWN ARE TO GENERAL CENTERLINE OF FENCE. THIS OFFICE WILL NOT BE RESPONSIBLE FOR DAMAGES RESULTING SOLELY ON THEIR PHYSICAL RELATIONSHIP TO THE MONUMENTED BOUNDARY LINES.
- 4) GRAPHIC REPRESENTATIONS MAY HAVE BEEN EXAGGERATED TO MORE CLEARLY ILLUSTRATE MEASURED RELATIONSHIPS - DIMENSIONS SHALL HAVE PRECEDENCE OVER SCALED POSITIONS.
- 5) UNDERGROUND IMPROVEMENTS HAVE NOT BEEN LOCATED EXCEPT AS SPECIFICALLY SHOWN.
- 6) ELEVATIONS ARE BASED UPON NATIONAL GEODETIC VERTICAL DATUM (N.G.V.D. 1929) OR NORTH AMERICAN VERTICAL DATUM (N.A.V.D. 1988).
- 7) ALL BOUNDARY AND CONTROL DIMENSIONS SHOWN ARE FIELD MEASURED AND CORRESPOND TO RECORD INFORMATION UNLESS SPECIFICALLY NOTED OTHERWISE.
- 8) CORNERS SHOWN AS "SET" ARE 5/8" IRON RODS IDENTIFIED WITH A PLASTIC CAP MARKED LS (LICENSED SURVEYOR)
- 9) I HEREBY CERTIFY THAT THIS SURVEY MEETS OR EXCEEDS THE STANDARDS OF PRACTICE SET FORTH BY THE FLORIDA BOARD OF PROFESSIONAL SURVEYORS AND MAPPERS PER CHAPTER 5J-17, FLORIDA ADMINISTRATIVE CODE, PURSUANT TO SECTION 472.027, FLORIDA STATUTES.

VERTICAL DATA IN N.G.V.D.
1929 (SURVEY FOOT)

- ALL ANGLES AND DISTANCES SHOWN HEREON ARE BOTH RECORD AND MEASURED UNLESS OTHERWISE NOTED

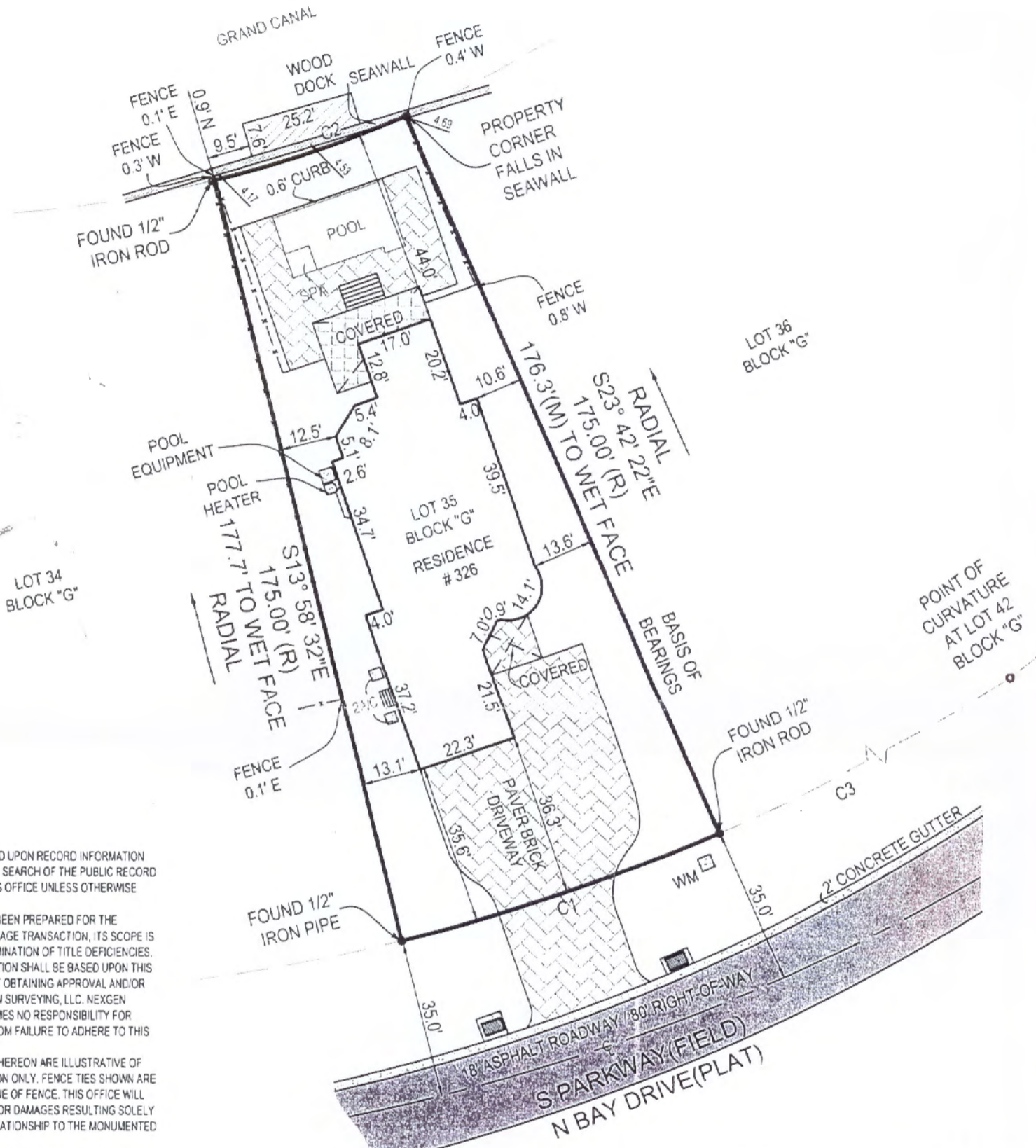

Curve Table			
Curve #	Length	Radius	Delta
C1	74.72'	440.00'	9° 43' 48"
C2	45.00'	265.00'	9° 43' 46"
C3	485.69'	440.00'	63° 14' 43"

LEGAL DESCRIPTION:

LOT 35, BLOCK G, OF SECTION "E" OF GOLDEN BEACH, ACCORDING TO THE PLAT THEREOF, AS RECORDED ON PLAT BOOK 8 PAGE 122, OF THE PUBLIC RECORDS OF MIAMI-DADE COUNTY, FLORIDA.

CERTIFIED TO:
KATHY WHEELER

FLOOD ZONE:
12086C0153L
ZONE: AE
ELEV: 7 FT
EFF: 09/11/2009

Clyde McNeal PSM 2883
THIS SURVEY IS NOT VALID WITHOUT THE SIGNATURE OF AND RAISED SEAL OF A FLORIDA LICENSED SURVEYOR AND MAPPER

Town of Golden Beach
Planning Regulatory Advisory Board
Meeting Date

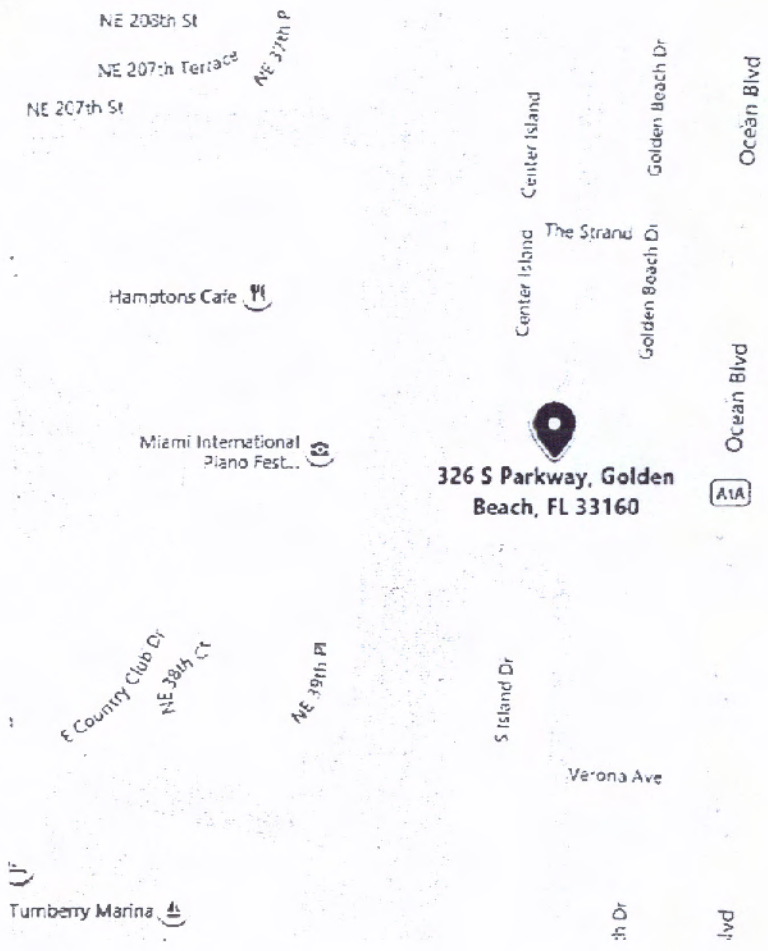

Location Map

Town of Golden Beach
Building Regulatory Advisory Board
Hearing Date

(12/18/20)

APPROVED: _____
DATE: _____
VARIABLE FILE: _____

PREPARED FOR:
SOUTHEAST MARINE CONST. INC
1121 NW 51 Court
Ft. Lauderdale, FI 33309
(954) 630-2300

Project:
Proposed Dock/Seawall Repair
LCM18 Solutions LLC
326 S Parkway
Golden Beach, Florida 33160

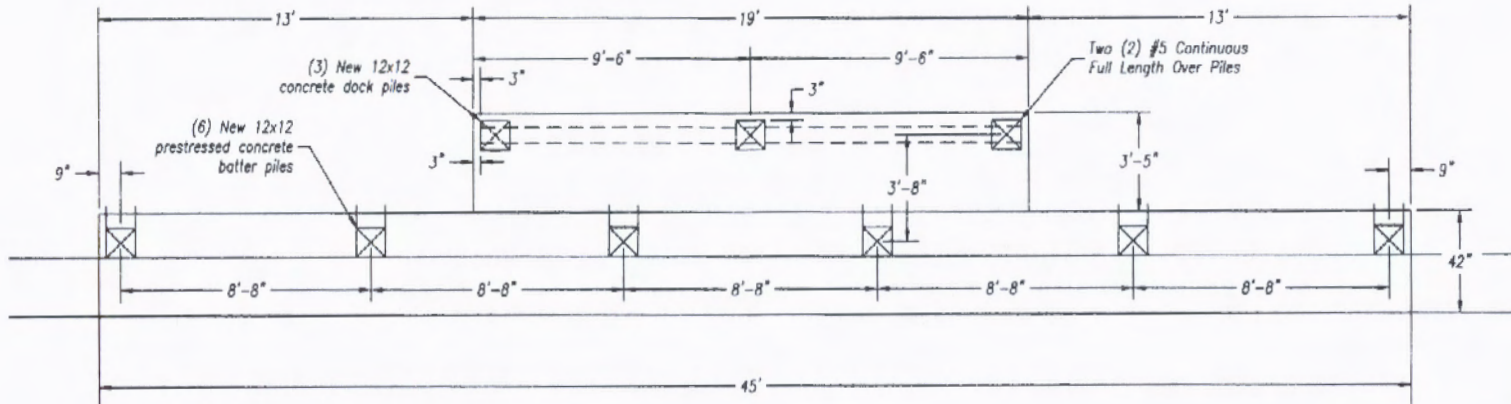

STEEL NOTE:

(1) Mat of #5s @ 12" each way not shown for clarity

Plan View
Scale 1/4" = 1'-0"

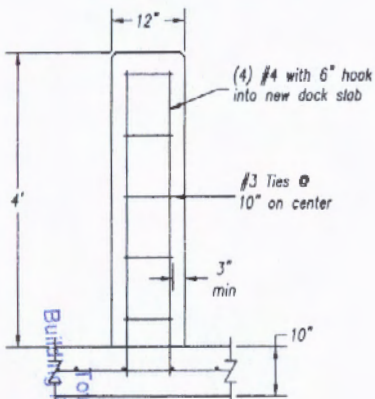

Pedestal Detail

Scale: 1/2" = 1'-0"

APPROVED
DISAPPROVED
VARIANCE REQ.

Building Department
Town of Golden Beach
Marine Advisory Board
Date

RER - NATURAL RESOURCES DIVISION
PRELIMINARY APPROVAL
NAME Micaela Soldi
DATE 09/02/2020



Sheet 3 of 6

PREPARED FOR
SOUTHEAST MARINE CONST. INC
1121 NW 51 Court
Ft. Lauderdale, FL 33309
(954) 630-2300

Project:
Proposed Dock/Seawall Repair
LCM18 Solutions LLC
326 S Parkway
Golden Beach, Florida 33160

JOHN OMSLAER, P.E.
E.B. #26829 | LICENSE #52733
DYNAMIC ENGINEERING SOLUTIONS INC
351 S. CYPRESS RD, SUITE #203
POMEROY BEACH, FLORIDA 33565
OFFICE (854) 545-1740

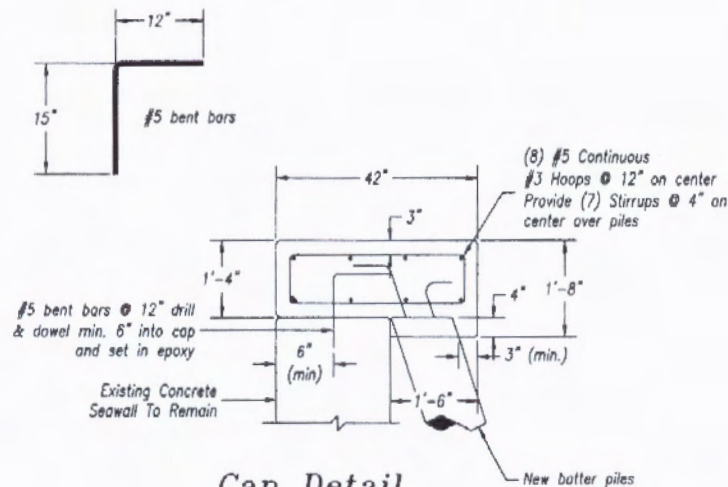

Cap Detail

Scale 1/2" = 1'-0"

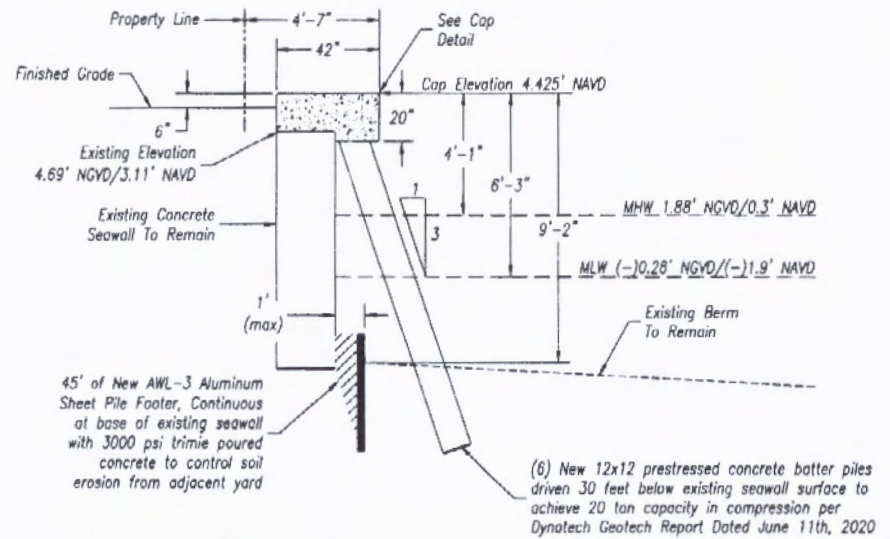

Seawall Repair Section

Scale 1/4" = 1'-0"

RER - NATURAL RESOURCES DIVISION
PRELIMINARY APPROVAL
 NAME Micaela Soldi
 DATE 09/02/2020

APPROVED
 DISAPPROVED
 VARIANCE REQ.

Town of Golden Beach
 Building Regulatory Advisory Board
 Meeting Date

Sheet 4 of 8

PREPARED FOR
 SOUTHEAST MARINE CONST. INC
 1121 NW 51 Court
 Ft. Lauderdale, FL 33309
 (954) 630-2300

Project:
 Proposed Dock/Seawall Repair
 LCM18 Solutions LLC
 326 S Parkway
 Golden Beach, Florida 33160

JOHN H. OMSLAER
 LICENSE
 No. 52733
 STATE OF
 FLORIDA
 PROFESSIONAL ENGINEER

JOHN OMSLAER, P.E.
 E.B. #26829 / LICENSE #52733
 DYNAMIC ENGINEERING SOLUTIONS INC
 351 S. CYPRESS RD, SUITE #303
 Pompano Beach, Florida 33060
 OFFICE (954) 545-1740

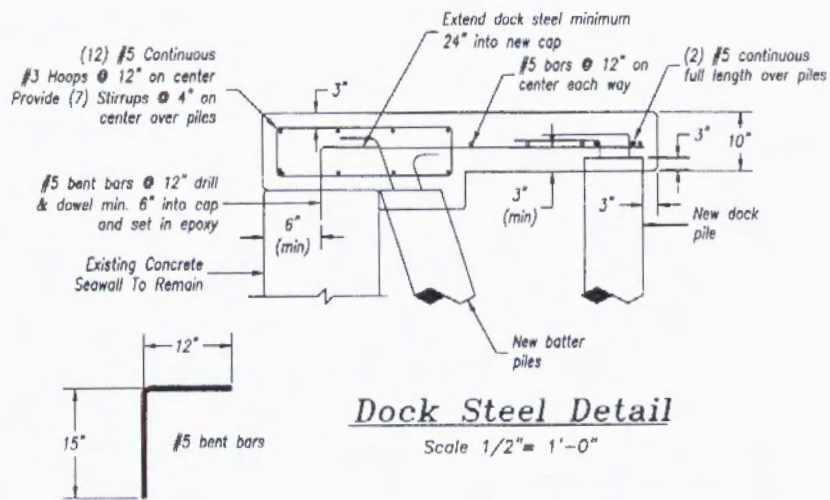

Dock Steel Detail

Scale 1/2" = 1'-0"

RER - NATURAL RESOURCES DIVISION
PRELIMINARY APPROVAL

NAME Micaela Soldi

DATE 09/02/2020

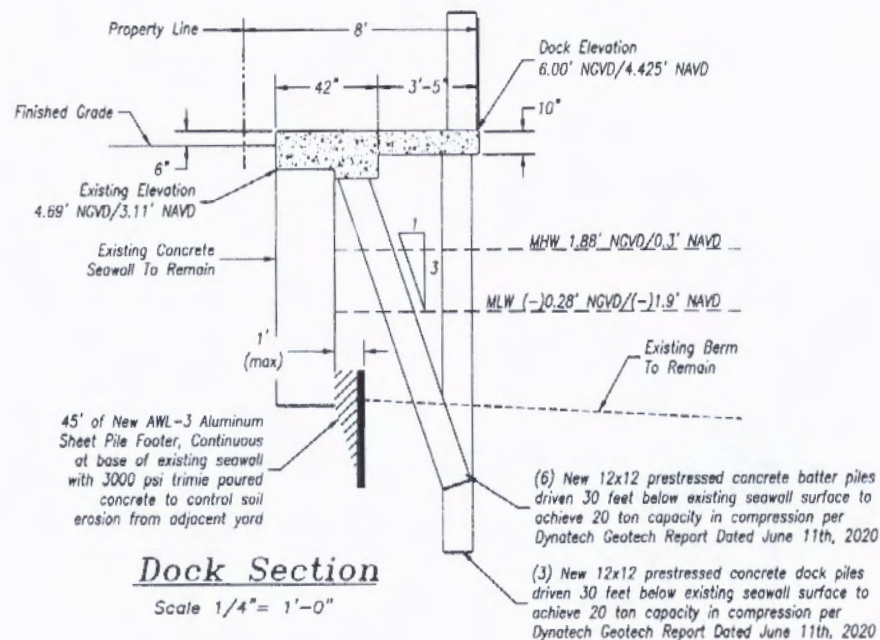

Dock Section

Scale 1/4" = 1'-0"

APPROVED
DISAPPROVED
VARIANCE REQ.

Town of Golden Beach
Building Regulatory Advisory Board

Sheet 5 of 6

PREPARED FOR
SOUTHEAST MARINE CONST. INC
1121 NW 51 Court
Ft. Lauderdale, FL 33309
(954) 630-2300

Project:
Proposed Dock/Seawall Repair
LCM18 Solutions LLC
326 S Parkway
Golden Beach, Florida 33160



JOHN H. OMSLAER, P.E.
E.B. #26829 | LICENSE #52733
DYNAMIC ENGINEERING SOLUTIONS INC
351 S. CYPRESS RD, SUITE #303
POMPANO BEACH, FLORIDA 33060
OFFICE (954) 545-1740

GENERAL NOTES:

1. Construction to follow the Florida Building Code 6th Edition (2017) and amendments as applicable and all Local, State and Federal Laws.
2. Licensed contractor shall verify the existing conditions prior to the commencement of the work. Any conflicts or omissions between existing conditions or the various elements of the working drawing shall be brought to the attention of the Engineer prior to the commencement of the work. The Licensed Contractor and all subcontractors are responsible for all lines, elevations, and measurements in connection with their work.
3. Do not scale drawings for dimensions.
4. Any deviation and/or substitution from the information provided herein shall be submitted to the Engineer for approval prior to commencement of work.
5. All unanticipated or unforeseen demolition and/or new construction conditions which require deviation from the plans and notes herein shall be reported to the Engineer prior to commencement of work.
6. All new work and/or materials shall conform to all requirements of each administrative body having jurisdiction in each appertaining circumstance.
7. All new materials and/or patchwork shall be provided to match existing materials and/or adjoining work where practical except as specifically noted herein.
8. Licensed Contractor to shall use all possible care to protect all existing materials, surfaces, and furnishings from damage during all phases of construction.
9. Licensed Contractor to verify location of existing utilities prior to commencing work.
10. The Licensed contractor to install and remove all shoring and bracing as required for the proper execution of the work.
11. Licensed Contractor to obtain all permits as necessary from all Local, State, and Federal agencies.
12. Turbidity barriers to be marked with site contractor's company name using permanent markings no smaller than 3 inches in height on the top of the barrier.

PILE DRIVING:

1. Pile driving operations shall be observed by a special inspector, including test piles sufficient to determine the approximate length required to meet design capacity.
2. Piles shall be driven using an approved cushion block consisting of material so arranged so as to provide the transmission of hammer energy.
3. Piles shall be driven to required capacity (min. 10 tons) a minimum of 8' into berm or refusal.
4. Piles shall be driven with a drop hammer or gravity hammer provided the hammer shall weight no less than 3,000 pounds, and the fall of the hammer shall not exceed 5'.
5. Piles shall be driven with a variation of not more than 1/4 inch per foot from the vertical, or from the batter line indicated, with a maximum variation of the head of the pile from the position shown on the plans of not more than three inches.
6. Where piling must penetrate strata offering high resistance to driving, the structural engineer of record or special inspector may require that the piles be set in pre-drilled or punched holes. The piles shall reach their final penetration by driving.

CONCRETE NOTES:

1. Concrete shall conform to ACI 318 (latest edition) and shall be regular weight, sulfate resistant, with a design strength of 5000 psi at 28 days with a maximum water-cementitious materials ratio, by weight aggregate concrete of 0.40.
2. Owner shall employ and pay for testing services from an independent testing laboratory for concrete sampling and testing in accordance with ASTM.
3. Licensed contractor is responsible for the adequacy of forms and shoring and for safe practice in their use and removal.
4. Concrete cover shall be 3" unless otherwise noted on the approved drawings.
5. Reinforcing steel shall be in conformance with the latest version of ASTM A615 Grade 60 specifications. All reinforcement shall be placed in accordance with ACI 315 and ACI Manual of Standard Practice.
6. Splices in reinforcing bars shall be not be less than 48 bar diameters and reinforcing shall be continuous around all corners and changes in direction. Continuity shall be provided at corners or changes in direction by bending the longitudinal steel around the corner 48 bar diameters.
7. Defective, cracked or loose concrete areas must be cut out, the rebar must be cleaned, coated with zinc and repaired with at least 3" of epoxy-concrete mix or gunnite concrete with sulfate-resistant cement.

PILE NOTES:

1. Concrete piles shall attain 6000 psi compressive strength in 28 days.
2. Concrete piles shall be reinforced with four - 7/8" lo-lax strands, 270 kips, and 5 ga. spiral ties.
3. Concrete piles shall be 12"x12" square, minimum length of 20'.
4. Concrete piles shall be cut to leave strands exposed a min. of 18" and tied to dock or cap steel or drill and epoxy (2) #5 8"x12" hook bars 6" into pile.

RER - NATURAL RESOURCES DIVISION
 PRELIMINARY APPROVAL
 NAME Micaela Soldi
 DATE 09/02/2020

APPROVED
 DISAPPROVED
 VARIANCE

Town of Golden Beach
 Building Regulatory Advisory Board
 Meeting Date

Sheet 6 of 6

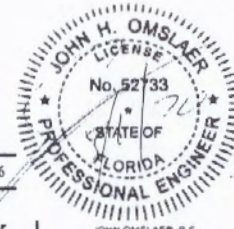

PREPARED FOR SOUTHEAST MARINE CONST. INC 1121 NW 51 Court Ft. Lauderdale, Fl 33309 (954) 630-2300	Project: Proposed Dock/Seawall Repair LCM18 Solutions LLC 326 S Parkway Golden Beach, Florida 33160	JOHN OMSLAER, P.E. E.B. #28829 LICENSE #52733 DYNAMIC ENGINEERING SOLUTIONS INC 351 S. CYPRESS RD. SUITE #303 Pompano Beach, Florida 33060 OFFICE: (954) 545-1740
--	---	--

LCM18 SOLUTIONS LLC
326 S PARKWAY
GOLDEN BEACH, FL 33160

VIVIAN NIREMBERG
330 S PARKWAY
GOLDEN BEACH, FL 33160

MANUEL HERNANDEZ & BONNIE
KELLY
343 CENTER ISL
GOLDEN BEACH, FL 33160

CHRISTIAN & OKSANA MASCIATTI
322 SOUTH PARKWAY
GOLDEN BEACH, FL 33160

334 S PARKWAY LLC
8333 NW 53 ST STE 501
MIAMI, FL 33166

APURVA R & JYOTI A DESAI
345 CENTRE ISLAND
GOLDEN BEACH, FL 33160

RICHARD & LAINIE GINSBURG
318 SOUTH PARKWAY
GOLDEN BEACH, FL 33160

GEORGE & KAREN RAIS
338 S PARKWAY
GOLDEN BEACH, FL 33160-2220

RALPH VELOCCI
349 CENTER ISL
GOLDEN BEACH, FL 33160

310 SOUTH PARKWAY LLC
310 S PARKWAY
GOLDEN BEACH, FL 33160

JEAN JACQUES MYARA
DEBORAH MYARA
3667 OAK AVE
NORTHBROOK, IL 60062

JASON RUBIN
268 S PARKWAY
GOLDEN BEACH, FL 33160-2219

STEVEN BLOCK TRS
140 SOUTH COLUMBIA AVE
COLUMBUS, OH 43209

ALICE K SCHLOSS TR
4525 NO PARK
INDIANAPOLIS, IN 46205

EDWARD ELENSON
DEBRA ELENSON
276 S PARKWAY
GOLDEN BEACH, FL 33160

ALAN & HELEN GAY BENENSON
304 S PARKWAY
MIAMI, FL 33160

OUR RILEY LLC
288 SOUTH PWKY
GOLDEN BEACH, FL 33160

GREGG D & SUSAN SCHNEIDER
288 S PARKWAY
GOLDEN BEACH, FL 33160-2219



TOWN OF GOLDEN BEACH
1 Golden Beach Drive
Golden Beach, Fl. 33160

SUMMARY MINUTES - Draft
BUILDING REGULATION ADVISORY BOARD
February 9, 2021 at 6pm

Zoom Meeting ID: 892 9110 8015 Passcode: 752288 For Dial in only call: 929-205-6099

- A. **CALL MEETING TO ORDER:** 6:00pm
- B. **BOARD ATTENDANCE:** Jerome Hollo, Judy Mimoun and Stephanie Halfen
- C. **STAFF ATTENDANCE:** Michael Miller – Michael Miller Planning, Linda Epperson – Director Building and Zoning, and Monica Diaz- Building Projects Coordinator
- D. **APPROVAL OF MINUTES:** December 8, 2020

Motion by Stephanie Halfen to approve the minutes, Seconded by Judy Mimoun
All were in favor – no one opposed
Motion passed 3 – 0

E. REQUEST FOR ADDITIONS, DEFERRALS, DELETIONS & WITHDRAWALS

- 1. Joel & Edith Newman
355 Ocean Blvd
Golden Beach, FL 33160-2211

Property Address: 355 Ocean Blvd, Golden Beach, FL 33160-0000
Folio No: 19-1235-002-0420
Legal Description: Lot 7 to 11 INC Blk B GB Sec B PB 9-52

Remodeling & Addition to existing SFR.

Motion to Defer item to the March 2021 Building Advisory Board meeting by Judy Mimoun, Seconded by Stephanie Halfen,
All were in favor – no one opposed
Motion passed 3 – 0

F. VARIANCE REQUEST(S):

- 2. LMC 18 Solutions LLC
326 S Parkway
Golden Beach, FL 33160

Property Address: 326 S Parkway, Golden Beach, FL 33160-0000
Folio No: 19-1235-005-0620
Legal Description: Lot 35 Blk G GB Sec E PB 8-122

Michael Miller – Michael Miller Planning summarized his report and it was entered into the record.
Mr. Leon Mochon spoke on his own behalf

Construction of a dock and seawall improvements.

Relief from Town Code Sec. 46-81. - Extension of seawall into waterways.
No part of any seawall, including slabs may extend beyond any lot property line into any waterway in the Town. The piles and cap beam may encroach into the waterway, if approved by the agency having jurisdiction.

Request is to allow the seawall to encroach into the waterway outside of the property line approximately 3'

In accordance with Town Code Section 66-41, "authorized, general procedure", pertaining to variances, the board considered all evidence and testimony presented by the applicant, the public and the Town and made a finding that the applicant has complied with the seven criteria.

A motion to recommend approval was made by Stephanie Halfen, Seconded by Judy Mimoun
On roll call: Stephanie Halfen-Aye, Judith Mimoun-Aye and Jerome Hollo- Nay
Motion passed 2 – 1

G. OLD BUSINESS:

3. LMC 18 Solutions LLC
326 S Parkway
Golden Beach, FL 33160

Property Address: 326 S Parkway, Golden Beach, FL 33160-0000
Folio No: 19-1235-005-0620
Legal Description: Lot 35 Blk G GB Sec E PB 8-122

Michael Miller – Michael Miller Planning – summarized his report and it was entered into the record

Patio Addition to existing SFR.

A motion was made by Judith Mimoun to approve the item, Seconded by Stephanie Halfen
On roll call: Judith Mimoun – Aye, Stephanie Halfen – Aye, Jerome Hollo-Aye
Motion passed 3 – 0

4. Joe Ackerman
Yael Marcuschamer
456 N Parkway St
Golden Bch, FL 33160

Property Address: 456 N PARKWAY ST, Golden Beach, FL 33160-0000
Folio No: 19-1235-006-0360
Legal Description: Lot 38 less S 10ft & All Lot 37, Blk F GB Sec E Pb 8-122

Michael Miller – Michael Miller Planning – summarized his report and it was entered into the record
Kirk Lofgren – Ocean Consulting spoke on behalf of the applicant.

New dock & decking at ~~existing~~ new SFR.

Chairperson Jerome Hollo asked if the boat when docked would protrude outside the D-5 triangle The Dock is 36 feet in length and pushed to the north/west of the property which sits on a curve. Kirk Lofgren stated that the boat would not protrude outside, the Town of Golden Beach triangle, and that DERM is fine with the placement, he noted that there are protected Seagrass all along that area, which is why they are limited on where to place the dock and dredging, Mr. Lofgren asked that the condition be made within the motion to move the item forward.

Mr. Hollo requested that the Affidavit contained in the current Building Advisory Board application, regarding seawalls and seawall heights be modified to include the statement regarding the positioning of the boats within the Golden Beach triangle.

Ms. Epperson acknowledged the request and stated the form would be modified to include the additional verbiage notifying applicants on boat placement.

A motion was made by Stephanie Halfen to approve the item, Seconded by Judith Mimoun
Conditioned on the boat when moored is within the Town of Golden Beach triangle as approved on the plans.

On roll call: Judith Mimoun – Aye, Stephanie Halfen – Aye, Jerome Hollo-Aye
Motion passed 3 – 0

5. Kenneth R. Bernstein
550 Golden Beach Drive
Golden Beach, FL 33160-2245

Michael Miller – Michael Miler Planning summarized his report and it was entered into the record.
Councilman Bernstein spoke on his own behalf
Tamara Peacock, Architect for the project was present

Property Address: 550 Golden Beach Drive, Golden Beach, FL 33160-0000
Folio No: 19-1235-006-0650
Legal Description: S ½ of Lot 10 to ALL of Lots 11 & 12 Blk F GB Sec F PB 10-11

Pergola with sitting/ Fire Pit/ Shower.

A motion to approve the item was made by Judith Mimoun, Seconded by Stephanie Halfen
On roll call: Judith Mimoun – Aye, Stephanie Halfen – Aye, Jerome Hollo-Aye
Motion passed 3 – 0

6. Ariel & Aline Levin
238 South Parkway
Golden Beach, FL 33160-2211

Property Address: 238 South Parkway, Golden Beach, FL 33160-0000
Folio No: 19-1235-004-0740
Legal Description: Lot 40 to 41 Blk J - GB Sec D PB 10-10

Michael Miller – Michael Miler Planning summarized his report and it was entered into the record.
Joseph Kahler – Architect for the project, spoke on behalf of the applicant.

Remodeling & Addition to existing SFR.

Chairman Hollo questioned on the screening of the mechanical equipment both existing and new.
The motion was amended to accept screening of the pool and a/c equipment in coordination with the
Building Department.

A motion to approve the item was made by Judith Mimoun, Seconded by Stephanie Halfen
Conditioned on screening of pool and a/c equipment.
On roll call: Judith Mimoun – Aye, Stephanie Halfen – Aye, Jerome Hollo-Aye
Motion passed 3 – 0

7. 422 GB LLC
422 Golden Beach Drive
Golden Beach, FL 33160-2211

Property Address: 422 Golden Beach Drive, Golden Beach, FL 33160-0000
Folio No: 19-1235-005-0510
Legal Description: Lot 45 & N1/2 of Lot 46 Blk F GB Sec E PB 8-122

Stephanie Halfen recused herself from voting on this item as she is the Architect of record for the project.
Michael Miller – Michael Miller Planning summarized his report and it was entered into the record.
Stephanie Halfen – Architect of record, spoke on behalf of the applicants.

Construction of a new single-family residence and landscape design approval.

Judith Mimoun made a motion to approve the item, Seconded by Jerome Hollo (Linda Epperson served as
quorum for this item)
Judith Mimoun – Aye, Jerome Hollo-Aye.
Motion passed 2 -0

8. Jean Jacques Myara
3667 Oak Ave
Northbrook, IL 60062

Property Address: 342 S Parkway, Golden Beach, FL 33160-0000
Folio No: 19-1235-005-0660
Legal Description: Lot 39 Blk G GB Sec E PB 8-122

Construction of a new single-family residence and landscape design approval.

Stephanie Halfen recused herself from voting on this item as she is the Architect of record for the project.

Michael Miller – Michael Miller Planning summarized his report and it was entered into the record.
Stephanie Halfen – Architect of record, spoke on behalf of the applicants.
A clarification was made that his property is an undersized lot not a full sized lot.

Judith Mimoun made a motion to approve the item, Seconded by Jerome Hollo (Linda Epperson served as quorum for this item)
Judith Mimoun – Aye, Jerome Hollo-Aye.
Motion passed 2 -0

H. NEW BUSINESS: None

I. PRELIMINARY DESIGN REVIEWS - ITEMS FOR DISCUSSION AND POSSIBLE APPROVAL

A brief discussion was had regarding the design review procedures for the Board. Chairperson Hollo asked Mr. Miller to also bring incentives for the roof lines of Mediterranean Architectural structures.

J. ADJOURNMENT

PURSUANT TO FLA. STATUTE 286.0105, THE TOWN HEREBY ADVISES THE PUBLIC THAT: IF A PERSON DECIDES TO APPEAL ANY DECISION MADE BY THIS BOARD WITH RESPECT TO ANY MATTER CONSIDERED AT ITS MEETING OR HEARING, HE WILL NEED A RECORD OF THE PROCEEDINGS, AND FOR THAT SUCH PURPOSE, AFFECTED PERSONS MAY NEED TO ENSURE THAT A VERBATIM RECORD OF THE PROCEEDINGS IS MADE, WHICH RECORD INCLUDES THE TESTIMONY AND EVIDENCE UPON WHICH THE APPEAL IS TO BE BASED. THIS NOTICE DOES NOT CONSTITUTE CONSENT BY THE TOWN FOR THE INTRODUCTION OR ADMISSION OF OTHER INADMISSIBLE OR IRRELEVANT EVIDENCE, NOR DOES I



TOWN OF GOLDEN BEACH

One Golden Beach Drive
Golden Beach, FL 33160

MEMORANDUM

Date: February 16, 2021

To: Honorable Mayor Glenn Singer &
Town Council Members

From: Lissette Perez, 
Town Clerk

Subject: **Town Council Minutes**

Item Numbers:

2

Recommendation:

It is recommended that the Town Council adopt the following attached minutes of the January 19, 2021 Regular Town Council Zoom Virtual Meeting.



TOWN OF GOLDEN BEACH

One Golden Beach Drive
Golden Beach, FL 33160

Official Minutes for the January 19, 2021
Regular Town Council Zoom Virtual Meeting called for 5:00 P.M.

Zoom Room Meeting ID: 861 9220 3598 Password: 241253

For Dial In Only: Call 929.205.6099 Meeting ID: 861 9220 3598

THE PUBLIC MAY PARTICIPATE AT GOOD AND WELFARE; PLEASE HOLD ALL QUESTIONS AND COMMENTS UNTIL THEN! THE PUBLIC IS ENCOURAGED TO SUBMIT ALL COMMENTS VIA EMAIL TO LPEREZ@GOLDENBEACH.US BY 2:00 P.M. TUESDAY, JANUARY 19, 2021.

A. MEETING CALLED TO ORDER

Mayor Singer called the meeting to order at 5:01 p.m.

B. ROLL CALL

Councilmember's Present: Mayor Glenn Singer, Vice Mayor Bernard Einstein, Councilmember Jaime Mendal, Councilmember Kenneth Bernstein, Councilmember Judy Lusskin

Staff Present: Town Manager Alexander Diaz, Town Attorney Steve Helfman, Police Chief Rudy Herbello, Town Clerk Lissette Perez, Finance Director Maria Camacho

C. PLEDGE OF ALLEGIANCE

Chief Herbello led the Pledge of Allegiance

D. PRESENTATIONS / TOWN PROCLAMATIONS

Town Manager stated that this meeting is being held via zoom per the emergency order issued by Mayor Singer. All town meetings will be held via zoom for the foreseeable future as our Council Chambers is not large enough to maintain safe social distance measures. Stated that the Council received a certificate for their compensation, instead of having the orchids and plaques given to them, we made a donation of \$100.00 in each of the members names to the South Florida Feed America Food Bank.

E. MOTION TO SET THE AGENDA

ADDITIONS/ DELETIONS/ REMOVAL OF ITEMS FROM CONSENT AGENDA/ AND CHANGES TO AGENDA

Town Manager stated that this afternoon the Council received an updated agenda. Item #5 was added to the agenda, authorizing the Town Manager to retroactively submit an agreement to the Department of Health to become an open and close point of

distribution for the COVID-19 vaccine. He will discuss the item in more detail when it comes up.

F. GOOD AND WELFARE

None

G. MAYOR'S REPORT

Wished everyone a Happy New Year. Need to emphasize continued safety, wear masks at all times and practice hygiene. Make sure all construction sites are wearing their masks, and ask residents walking around to wear them as well. This year is a busy year for us, we have the new town civic center, Center Island pump station, bus shelters and we are looking at adding internet high-speed fiber throughout the Town. Congratulated Councilmembers Mendal and Lusskin who were re-elected, unopposed. Thanked the residents that believe in him, he is going into his 9th term and he is still as motivated and excited as he was in his first term.

H. CORONAVIRUS UPDATE

Number of cases in Golden Beach continue to rise, 58 of our residents have tested positive and 8 of our employees have tested positive since the pandemic began. Two residents passed away as a result of COVID. We ask the residents to continue to use the masks, and hand sanitizers. We have a new self-administer antigen test that we procured, we are providing them directly to the homes that request them. Police have been going to construction sites asking them to wear a mask; two weeks ago, we shut down a construction site. We shut down Tweddle Park so we will have less people there.

I. COUNCIL COMMENTS

Vice Mayor Einstein

Congratulated Councilmembers Lusskin and Mendal, and Mayor Singer on going unopposed. Town looks very good, asked for more details on Center Island Pump Station.

Councilmember Bernstein

Wished everyone a happy new year and congratulated the Mayor, and Councilmembers Lusskin and Mendal and on their re-elections. Congratulated the Town on being on the front line for 2020, getting COVID testing and now looking at ways to get vaccines into Town. Thanked everyone for pressing the speed of the internet in Town.

Councilmember Lusskin

Extended condolences to resident Dina Nicolella for the passing of her brother recently. Stated that a few months ago Councilmember Bernstein commented about the number of iguanas, does not know what to say, and wants to know if there is anything, we can do about them. Received phone calls in regards to the dog park, if the Manager can talk about if we are going to keep both closed or if there is a way to open one. Was very surprised at how popular pickle ball is, knows we had some vandalism there if the Manager can go over that.

Councilmember Mendal

Congratulated Councilmember Lusskin and Mayor Singer. Stated the Town looks great.

J. TOWN MANAGER REPORT

Wished everyone a Happy New Year. We are looking forward to 2021 we have a lot on our plate, many exciting projects. We had a tremendous amount of positive feedback on this year's holiday gifts that were delivered to the homes. This year we will not have an election – Councilmembers Luskkin and Mendal, and Mayor Singer have been re-elected, but we have to validate the results in our February meeting. There will be a Swearing-in ceremony on Sunday February 21st at 11:00 am on the sand at the Beach, it will be socially distanced. Although the agendas will be light this year, that does not mean that there is not a lot of work to do. He has provided the Council with a memo outlining the projects that we will be working on for the first quarter of this year. We have increased our police efforts as a result of what is going on in our nation and in the state. Asked the residents to keep an eye out and report anything that looks unusual to the substation. We submitted three projects to the State for this year's funding program. As required there will be a memo sent to the Council tomorrow outlining our film activity for 2020, it is no surprise that it is little to none. As it relates to the dog park, we have no intentions to create another dog park anywhere in Town until the project is delivered. Right now there is no place where he can place a temporary dog park where it won't be abused by people outside of Golden Beach. As it relates to the pickle ball court there was some vandalism done to the tennis nets that has all been corrected. Wanted to remind the Council and residents that the pickle ball court is temporary. Where the pickle ball court sits today, a crane will be stationed there. Thanked staff for their work and service during the COVID pandemic. There are still many cities that are working remotely and our staff is back in the office and working every day.

Councilmember Mendal inquired about the pickle ball court, if we can draw the pickle ball lines on the tennis courts temporarily.

Town Manager stated that that is an excellent observation, the Mayor mentioned it as well; yes, we will do that once we have to shut down the pickle ball court.

Vice Mayor Einstein asked if the new dog park has a big dog section and a small dog section.

Town Manager we have not approved a site plan for that site, there is still a lot of moving parts on that site plan. Nothing set in stone yet, right now it shows one big area and does not designate small or big.

K. TOWN ATTORNEY REPORT

None

L. ORDINANCES – SECOND READING

None

M. ORDINANCES - FIRST READING

None

N. QUASI JUDICIAL RESOLUTIONS

None

**** At this point in time the Council observed a moment of silence on behalf of all of the victims of COVID-19. ****

Vice Mayor Einstein mentioned that long-time resident Neil Leff passed away recently and extended his condolences to Mr. Leff and his family.

O. TOWN MAJOR PROJECTS UPDATE

- Civic Center Complex Masterplan- stated we have fenced off the area of that construction site. If you are caught inside that fence at any time you can get arrested, this is being done for your safety and the safety of those working there. We are in permit review. There has been a little bit of a snag as it relates to our structural plans review. Lissett and him are working with the Towns engineers to make sure we correct the snag we are in. We will start to see some site work preparations over the next two weeks. Waiting on some last minute DERM permits before we can start tree removal. We are on track and the project schedule has not changed. There have been some hiccups as it relates to soil condition surveys that were done; we are working with the contractor on making sure we are not sacrificing anything in terms of design. At your March meeting, there will be a video and renderings in terms of final products such as hallways, door handles, carpet, etc. We have contracted with a company to animate that for you to make sure all of our residents and Council can see a walk-through of the building. There are a couple RFPs that Lissett and him are working on as it relates to furniture and equipment.
- Center Island Pump Station- thanked Maria Camacho, Lissette Perez, and Ingrid Gooden for working hard on something that we have never done before for projects. We have decided to be the purchaser of all of the major items for the Center Island Pump Station. By the Town buying all of the major items we are able to generate a \$30,000 savings by not paying taxes on those items. This project is also on schedule. We have a little hiccup because we are using state money for that project all of the items has to be Made in America, if they are not they do not qualify for reimbursement. Two of the items if we buy American will delay the project by close to 3 months, we are asking the State to give us an exception to allow us to buy those products with our own money. We do not want to delay the project because of a pipe. Still have not done the exploratory work to see how the seawall separated. The decision was made by the administration to wait until the king tide period is over. Reminded Council that the wall has spilt on two corners of that area. Will schedule that for some time in February.
- Fiber/High Speed Internet – stated that the Mayor has taken a very active lead on this. Lissett Rovira and Manager had been working on detailing an RFP that dictates what the Town wants. What we will do instead is issue an RFP where we tell the bidding community what our desires are, and have them tell us the best what to achieve that. At a minimum we will put that we would like to have fiber or better, and that we also want to offer Wi-Fi at our parks. At each meeting, we will keep Item O where we will give you updates on the major items in Town.

Vice Mayor Einstein asked if the Town is still looking at a bulk contract for the fiber.

Town Manager stated that yes, but also wants all of the providers to tell us what they feel would be the best way to offer better connectivity to our residents.

Councilmember Mendal asked if there have been any updates on the technological advancements that we were planning on doing for the Building Department.

Town Manager stated yes that will be one of the RFP's at the end of the year. The Mayor and Manager made a commitment to both the staff and to themselves that when we enter the new building we are leaving everything behind. The goal is to not transfer anything from the current network into the new building. So, we will upgrade our accounting software which we have not done in over 18 years and get an integrated online permitting system. We may advance the Building Department before we go to the new building. Our current software that we have for the Building Department is called Energov. It does have an online interface, we are negotiating with them to see what it would take for us to upgrade this system, the cost is about a \$30,000 to upgrade.

P. CONSENT AGENDA

- 1. Official Minutes of the November 24, 2020 Local Planning Agency Zoom Virtual Hearing**
- 2. Official Minutes of the November 24, 2020 Special Town Council Zoom Virtual Meeting**
- 3. A Resolution of the Town Council Retiring K-9 Dog Tyson.**

A RESOLUTION OF THE TOWN COUNCIL OF THE TOWN OF GOLDEN BEACH, FLORIDA, DECLARING CERTAIN PERSONAL PROPERTY (POLICE K-9 DOG) OWNED BY THE TOWN TO HAVE NO INSTRINSIC MONETARY VALUE AND PROVIDING FOR DISPOSITION; AUTHORIZING THE TOWN MANAGER TO PROVIDE FOR THE DISPOSITION OF SUCH PERSONAL PROPERTY BY BILL OF SALE; PROVIDING FOR IMPLEMENTATION; AND PROVIDING FOR AN EFFECTIVE DATE.

Exhibit: Agenda Report No. 3
Resolution No. 2716.21

Sponsor: Town Administration

Recommendation: Motion to Approve Resolution No. 2716.21

Consensus vote 5 Ayes, 0 Nays. Items P1 – P3 pass.

Q. TOWN RESOLUTIONS

- 4. A Resolution of the Town Council Authorizing the Sole Source Purchase of Bus Shelters.**

A RESOLUTION OF THE TOWN COUNCIL OF THE TOWN OF GOLDEN BEACH, FLORIDA, AUTHORIZING THE SOLE

SOURCE PURCHASE OF BUS SHELTERS FROM LANDSCAPE FORMS INC. FOR AN AMOUNT NOT TO EXCEED \$59,000; PROVIDING FOR IMPLEMENTATION; PROVIDING FOR AN EFFECTIVE DATE.

Exhibit: Agenda Report No. 4
Resolution No. 2717.21

Sponsor: Town Administration

Recommendation: Motion to Approve Resolution No. 2717.21

A motion to approve was made by Councilmember Luskin, seconded by Vice Mayor Einstein.

On roll call, the following vote ensued:

Mayor Glenn Singer	<u>Aye</u>
Vice Mayor Bernard Einstein	<u>Aye</u>
Councilmember Judy Luskin	<u>Aye</u>
Councilmember Jaime Mendal	<u>Aye</u>
Councilmember Kenneth Bernstein	<u>Aye</u>

The motion passed.

Town Manager spoke on the item. What we're doing to build these bus shelters is we're using Mainguy to do the landscaping, Biscayne Iron works to do the fencing, Southeast Engineering to do the plumbing, electrical, and build the actual shelters. He will be the General Contractor for these project, and will be hiring the subcontractors. Most of the work that the subcontractors are doing are below his spending authority. We are treating each shelter as a separate location and separate project. However, these shelters are only made by one company that Council has blessed, and individually they are still over his spending authority that is why the item is in front of them tonight. The total amount of the project is \$134,100; we have \$111,232 coming from CITT, which leaves us with \$22,000 to pay for. He reminded the Council that as CITT money comes in, we will pay back that \$22,000.

Councilmember Bernstein asked if we can put chairs for people to sit while they wait, because if they have to stand the whole time it defeats the purpose.

Town Manager agreed, stated after we take delivery of the site itself and we see what it looks like, we will explore the possibility of installing individual seating. He will get some ideas over to Councilmember Bernstein for his consideration.

Mayor Singer agreed that we will need seating

5. A Resolution of the Town Council Retroactively Approving a COVID-19 Vaccination Site Agreement between the Town and the Miami-Dade County Health Department.

A RESOLUTION OF THE TOWN COUNCIL OF THE TOWN OF GOLDEN BEACH, FLORIDA, RETROACTIVELY

APPROVING A COVID-19 VACCINATION SITE AGREEMENT BETWEEN THE STATE OF FLORIDA, DEPARTMENT OF HEALTH, MIAMI-DADE COUNTY HEALTH DEPARTMENT AND THE TOWN OF GOLDEN BEACH FOR THE TOWN TO ADMINISTER THE COVID-19 VACCINATION; PROVIDING FOR IMPLEMENTATION; AND PROVIDING FOR AN EFFECTIVE DATE.

Exhibit: Agenda Report No. 5
Resolution No. 2718.21

Sponsor: Town Administration

Recommendation: Motion to Approve Resolution No. 2718.21

A motion to approve was made by Councilmember Lusskin, seconded by Councilmember Bernstein.

On roll call, the following vote ensued:

Mayor Glenn Singer	<u>Aye</u>
Vice Mayor Bernard Einstein	<u>Aye</u>
Councilmember Judy Lusskin	<u>Aye</u>
Councilmember Jaime Mendal	<u>Aye</u>
Councilmember Kenneth Bernstein	<u>Aye</u>

The motion passed.

Town Manager spoke on the item. Stated with COVID ever evolving we are trying to stay ahead of municipalities. The state was looking for additional entities that can become vaccine locations to administer the vaccine. We immediately submitted an application seeking two closed pods. One for our employees, family and friends, and one for our residents, their family, and friends. We have been approved for both, what that means is that the Administration will now need to put together a plan on how we will administer the vaccine. We are required to provide nurses, a doctor, and an EMT team in case someone has a bad reaction. Already reached out to Miami-Dade Fire & Rescue and AMR to provide us with those services. Also reached out to three local staffing company's, one of them being the people currently doing our testing, we are negotiating a fee for them to come and vaccinate us. The states commitment, once our plan is approved and the general public can be vaccinated, they will add us to the list of sites to receive the vaccine. We are the third city in Miami-Dade County to be approved by the state to be an actual municipal vaccination site. This is a big win for the Administration. We are going to be pursuing this aggressively. The sooner we can vaccinate the Golden Beach population, the better. He feels confident that we can use our reserves to pay for this. In addition, the state will reimburse those costs. Even if we do not get reimbursed, if we have money to provide holiday gifts, he will find money to get vaccines to our residents should the Governor release them to us.

Councilmember Bernstein asked if the vaccinations are only for employees and residents.

Town Manager stated the way the agreement reads is the employees and their intermediate families and the residents and their intermediate families.

Vice Mayor Einstein stated that right now it seems that the way this is being administered, this is a different scenario.

Town Manager stated that what they have now is an open pod, where anyone can come to a location and get vaccinated. With a closed pod, the vaccination administration is closed off to persons outside of the specified group.

R. DISCUSSION & DIRECTION TO TOWN MANAGER

Mayor Glenn Singer:
None Requested

Vice Mayor Bernard Einstein:
None Requested

Councilmember Judy Lusskin:
None Requested

Councilmember Jaime Mendal:
None Requested

Councilmember Kenneth Bernstein:
None Requested

Town Manager Alexander Diaz
None Requested

Town Manager reminded council that the Swearing-In Ceremony is on February 21st, 2021, the February and March meetings will be via zoom at 5:00PM.

S. ADJOURNMENT:

A motion to adjourn the Council Meeting was made by Mayor Singer seconded by Councilmember Lusskin.

Consensus vote 5 Ayes 0 Nays. Motion passes.

The meeting adjourned at 6:02 p.m.

Respectfully submitted,

Lissette Perez
Lissette Perez
Town Clerk



TOWN OF GOLDEN BEACH

One Golden Beach Drive
Golden Beach, FL 33160

MEMORANDUM

Date: February 16, 2021

Item Number:

To: Honorable Mayor Glenn Singer &
Town Council Members

3

From: Lissette Perez,
Town Clerk 

Subject: **Resolution No. 2720.21 – Acceptance of 2021 General Election Results**

Recommendation:

It is recommended that the Town Council adopt the attached Resolution No. 2720.21.

Background:

The qualifying period for the Town's 2021 General Election was held from December 28, 2020 through January 4, 2021. Mayor Glenn Singer, Councilmember Judy Lusskin and Councilmember Jaime Mendal ran unopposed.

Pursuant to Florida Statute 101.151. **Specifications for ballots** – states; “the names of unopposed candidates shall not appear on the general election ballot. Each unopposed candidate shall be deemed to have voted for himself or herself.” Therefore, the election was cancelled and the unopposed candidates are determined to be “elected unopposed.”

Pursuant to the Town Charter, the Town Council shall accept the certification of the results of the election and designate a Vice Mayor.

By mutual agreement, Councilmember Judy Lusskin will serve as Vice Mayor upon adoption of this resolution through the February 2022 Regular Town Council meeting at which time Councilmember Jaime Mendal will serve as Vice Mayor through the February 2023 Regular Town Council Meeting.

Fiscal Impact:

None

TOWN OF GOLDEN BEACH, FLORIDA

RESOLUTION NO. 2720.21

A RESOLUTION OF THE TOWN COUNCIL OF THE TOWN OF GOLDEN BEACH, FLORIDA, ACCEPTING THE TOWN CLERK'S CERTIFICATION OF THE RESULTS OF THE FEBRUARY 16, 2021 TOWN ELECTION FOR MAYOR AND TWO TOWN COUNCILMEMBERS, DESIGNATING THE VICE MAYOR; PROVIDING FOR SEVERABILITY; PROVIDING FOR CONFLICT AND PROVIDING AN EFFECTIVE DATE.

WHEREAS, pursuant to law and properly noticed, qualifying for a municipal election was held from December 28, 2020 to January 4, 2021 in the Town of Golden Beach; and

WHEREAS, the Town Council desires to accept the unopposed re-election of Glenn Singer for a ninth term as Mayor; and

WHEREAS, for the Town Council desires to accept the unopposed re-election of Jaime Mendal for a second term and Judy Lusskin for a fifth term as Councilmembers; and

WHEREAS, the Town Council desires to designate a Vice Mayor pursuant to the Town Charter.

NOW THEREFORE BE IT RESOLVED BY THE TOWN COUNCIL OF THE TOWN OF GOLDEN BEACH, FLORIDA, AS FOLLOWS:

Section 1. That the Certification of the qualifying results of the February 16th, 2021 town election is accepted as follows:

- | | | | |
|----|------------------------------|-----------------------------|------------------------|
| A. | Mayor
2 year term | Glenn Singer | Unopposed |
| B. | Town Council:
4 year term | Judy Luskin
Jaime Mendal | Unopposed
Unopposed |

- Section 2.**
- A. That based upon the results, Glenn Singer is declared Mayor for a two-year term commencing immediately.
 - B. That based upon the results, Judy Luskin is declared Town Councilmember for a four year term, commencing immediately.
 - C. That based upon the results, Jaime Mendal is declared Town Councilmember for a four year term, commencing immediately.

Section 3. That Councilmember Judy Luskin is hereby designated Vice Mayor for one-year term commencing immediately, to be followed by Councilmember Jaime Mendal, Vice Mayor for the succeeding one-year term as decided by the Town Council.

Section 4. Severability. That the provisions of this Resolution are declared to be severable and if any section, sentence, clause or phrase of this Resolution shall, for any reason, be held to be invalid or unconstitutional, such decision shall not affect the validity of the remaining sections, clauses, sentences and phrases of this Resolution but they shall remain in effect, notwithstanding the invalidity of any part.

Section 5. Conflict. That all resolutions or parts of resolutions in conflict with this Resolution are hereby repealed to the extent of such conflict.

Section 6. Effective Date. That this Resolution shall become effective immediately upon approval of the Town Council.

Sponsored by Town Administration.

The Motion to adopt the foregoing Resolution was offered by _____,
seconded by _____ and on roll call the following vote ensued:

Mayor Glenn Singer	_____
Vice Mayor Bernard Einstein	_____
Councilmember Kenneth Bernstein	_____
Councilmember Judy Lusskin	_____
Councilmember Jaime Mendal	_____

PASSED AND ADOPTED by the Town Council of the Town of Golden Beach
this 16th day of February, 2021.

MAYOR GLENN SINGER

ATTEST:

LISSETTE PEREZ
TOWN CLERK

APPROVED AS TO FORM
AND LEGAL SUFFICIENCY

STEPHEN HELFMAN
TOWN ATTORNEY



TOWN OF GOLDEN BEACH

One Golden Beach Drive
Golden Beach, FL 33160

MEMORANDUM

Date: February 16, 2021

To: Honorable Mayor Glenn Singer &
Town Council Members

From: Alexander Diaz, *Alex B*
Town Manager

Subject: **Resolution 2721.21 – Approving the Proposal from
Southeastern Engineering Contractors, Inc. for the Installation
of Two Bus Shelters in Town**

Item Number:

4

Recommendation:

It is recommended that the Town Council adopt the attached Resolution No. 2721.21 as presented.

Background:

The Town will be installing bus shelters at two locations along A-1-A. The Administration is serving as the Project Manager for the installation and has contracted directly with the various sub-contractors to deliver this project.

We have contracted with Mainguy for landscaping, Biscayne Iron Works for fencing, direct purchase of the bus shelters with Landscape Forms, and we are seeking your approval to engage Southeastern Engineering Contractors, Inc. (SEC) for the site preparation and shelter installation.

Unlike the other contracts where we can direct purchase items within my legal purchasing authority, the SEC work is mainly for service. Their proposal exceeds my spending authority and requires your approval.

Fiscal Impact:

\$49,990.00

TOWN OF GOLDEN BEACH, FLORIDA

RESOLUTION NO. 2721.21

A RESOLUTION OF THE TOWN COUNCIL OF THE TOWN OF GOLDEN BEACH, FLORIDA, APPROVING THE PROPOSAL PROVIDED BY SOUTHEASTERN ENGINEERING CONTRACTORS, INC. FOR THE DELIVERY, SITE PREPARATION AND INSTALLATION OF TWO BUS SHELTERS IN TOWN; PROVIDING FOR A WAIVER OF BIDDING PROCEDURES; PROVIDING FOR AUTHORIZATION; PROVIDING FOR IMPLEMENTATION; AND AN EFFECTIVE DATE.

WHEREAS, the Town Council approved via Resolution 2717.21 the Sole Source Purchase of Two Bus Shelters from Landscape Forms Inc.; and

WHEREAS, upon purchase of the bus shelters, the Administration will need to coordinate the delivery, site preparation and installation of the Two Bus Shelters; and

WHEREAS, the Town Council finds that compliance with the bid procedures set forth in the Town's Code of Ordinances (the "Town Code") is impractical and not in the best interest of the Town; and

WHEREAS, the Town Council has determined that the proposal submitted by Southeastern Engineering Contractors, Inc. attached hereto as Exhibit "A," (the "Proposal") is acceptable and will well serve the needs of the Town residents.

NOW, THEREFORE, BE IT RESOLVED BY THE TOWN COUNCIL OF THE TOWN OF GOLDEN BEACH, FLORIDA, AS FOLLOWS:

Section 1. Recitals Adopted. Each of the above stated recitals are hereby adopted and confirmed.

Section 2. Proposal Approved. The Town Council hereby approves the Proposal.

Section 3. Waiver of Competitive Bidding. The Town Council finds that compliance with the bid procedures within the Town Code is impractical and hereby waives such procedures in accordance with Section 2-275 of the Town Code.

Section 4. Implementation. The Town Mayor and Town Manager are hereby directed to take all steps necessary to implement this Resolution, including the execution of the Proposal and/or contract approval by the Town Attorney.

Section 5. Effective Date. This Resolution shall be effective immediately upon adoption.

The Motion to adopt the foregoing Resolution was offered by _____, seconded by _____ and on roll call the following vote ensued:

Mayor Glenn Singer	_____
Vice Mayor Judy Lusskin	_____
Councilmember Bernard Einstein	_____
Councilmember Jaime Mendal	_____
Councilmember Kenneth Bernstein	_____

PASSED AND ADOPTED by the Town Council of the Town of Golden Beach, Florida, this 16th day February, 2021.

MAYOR GLENN SINGER

ATTEST:

LISSETTE PEREZ
TOWN CLERK

APPROVED AS TO FORM
AND LEGAL SUFFICIENCY:

STEPHEN J. HELFMAN
TOWN ATTORNEY

PROPOSAL

TOWN OF GOLDEN BEACH

DATE: 01/12/2021

PROJECT DESCRIPTION: BUS SHELTERS INSTALLATION AND WATER SERVICES.

FINANCIAL PROJECT ID: N/A

PROJECT NO.: N/A

Item	Description	Unit	Qty	U. Price	Total
<u>General Items</u>					
1	Mobilization	LS	1.00	1,300.00	1,300.00
2	MOT	LS	1.00	680.00	680.00
3	Environmental Compliance	LS	1.00	750.00	750.00
4	Site Preparation	LS	1.00	1,350.00	1,350.00
<u>Irrigation Services Connection</u>					
5	Excavation, removal and disposal of surplus material	LS	1.00	1,200.00	1,200.00
6	Tapping Sleeve 8" x 2", w/ Corp Stop and Gate Valve	EA	2.00	2,300.00	4,600.00
7	2" HDPE Directional Drill Irrigation Line (32OLF)	LS	1.00	8,790.00	8,790.00
8	Irrigation Meter Box and Pressure Vacuum Breaker w/6" Concrete Slab	EA	2.00	3,900.00	7,800.00
9	Milling & Pavement Restoration (Asphalt 1") (Min. Charge)	LS	1.00	3,100.00	3,200.00
10	Striping (Min. Charge)	LS	1.00	1,400.00	1,400.00
<u>Bus Shelters Installation</u>					
11	Remove Existing Fence	LS	1.00	500.00	500.00
12	Reinforced 6" Concrete Slab w/ Thickened Edge for Shelters	EA	2.00	2,270.00	4,540.00
13	6" Layer Crushed Limestone Base	EA	2.00	690.00	1,380.00
14	Shelter Assembly and Installation	EA	2.00	5,900.00	11,800.00
15	Final Cleaning	LS	1.00	700.00	700.00
TOTAL					49,990.00

Payment Terms:

The price(s) quoted here are based on the quantities/measurements stated above. Any change in measurement or quantity may result in a price adjustment. Customer agrees to pay interest on past due payments at the highest rates allowed by law from when payment is due until payment is received by Southeastern. Customer agrees to pay all costs of collections due to non payment and reasonable attorney fees of the contractor in any effort to collect moneys under this agreement. All prices quoted are good for 30 days.

Exclusions: Permit fees unless specifically accounted for above, HOA fees, landscape restoration or any other work not specifically listed or described in this proposal. If you do not see an item of work described above please do not assume that it is accounted for.

If needed, Town to provide for police services at no cost to SEC.

All work to be performed during daylight hours. Add 1.5 x labor costs for night work.

No restoration or repairs work such as landscaping, irrigation, etc., etc. is included in above items.

Submitted by: **Southeastern Engineering Contractors, Inc.**
 911 NW 209th Avenue, Suite 101
 Pembroke Pines, Fl. 33029

Accepted by: _____

 Town of Golden Beach



TOWN OF GOLDEN BEACH

One Golden Beach Drive
Golden Beach, FL 33160

MEMORANDUM

Date: February 16, 2021

To: Honorable Mayor Glenn Singer &
Town Council Members

From: Alexander Diaz, *Alex B.*
Town Manger

Subject: Resolution No. 2722.21 – Assigning Councilmember’s The
Duty To Inquire Into The Operation Of A Particular Area Of
Town Operation

Item Number:

5

Recommendation:

It is recommended that the Town Council adopt the attached Resolution No. 2722.21 as presented.

Background:

Section 3.05 of the Town Charter calls for the Town Council to be assign the duty to inquire into the operation of a particular area of governmental responsibility for a period of six months in order for the Councilmember to become informed as to the objectives of the government of the Town.

The current assignments are as follows:

Mayor Singer	<u>Finance Department</u>
Vice-Mayor Luskin	<u>General Government</u>
Councilmember Bernstein	<u>Building & Zoning Department</u>
Councilmember Mendal	<u>Police Department</u>
Councilmember Einstein	<u>Public Works Department</u>

We propose the following assignment through the next Town Elections:

February 2021 to August 2021

Mayor Singer	<u>General Government</u>
Vice-Mayor Luskin	<u>Public Works Department</u>
Councilmember Bernstein	<u>Police Department</u>
Councilmember Mendal	<u>Finance Department</u>
Councilmember Einstein	<u>Building & Zoning Department</u>

September 2021 to February 2022

Mayor Singer	<u>Finance Department</u>
Vice-Mayor Lusskin	<u>Building & Zoning Department</u>
Councilmember Bernstein	<u>Public Works Department</u>
Councilmember Mendal	<u>General Government</u>
Councilmember Einstein	<u>Police Department</u>

Fiscal Impact:

None

TOWN OF GOLDEN BEACH, FLORIDA

RESOLUTION NO. 2722.21

A RESOLUTION OF THE TOWN COUNCIL OF THE TOWN OF GOLDEN BEACH, FLORIDA ASSIGNING EACH COUNCILMEMBER THE DUTY TO INQUIRE INTO THE OPERATION OF A PARTICULAR AREA OF GOVERNMENTAL RESPONSIBILITY; PROVIDING FOR CONFLICT; PROVIDING FOR IMPLEMENTATION; AND PROVIDING AN EFFECTIVE DATE.

WHEREAS, pursuant to Section 3.05 of the Town Charter of the Town of Golden Beach, Florida, the Town Council shall assign each Councilmember the duty to inquire into the operation of a particular area of governmental responsibility for a period of six months in order for the Councilmember to become informed as to the objectives of the government of the Town; and

WHEREAS, for added efficiency the Council would also like to assign each Councilmember the duty to inquire into the operation of a particular area of governmental responsibility for the following six month period; and

WHEREAS, the Council finds that the assignments as specified herein are in the best interest of the Town.

NOW THEREFORE BE IT RESOLVED BY THE TOWN COUNCIL OF THE TOWN OF GOLDEN BEACH, FLORIDA, AS FOLLOWS:

Section 1. Recitals Adopted. That each of the recitals stated above is hereby adopted and confirmed.

Section 2. Assignments. That in accordance with Section 3.05 of the Town Charter, the following assignments are hereby approved and shall remain in effect for a period of six months, from February 2021 to August 2021:

Mayor Singer	<u>General Government</u>
Vice-Mayor Lusskin	<u>Public Works Department</u>
Councilmember Bernstein	<u>Police Department</u>
Councilmember Mendal	<u>Finance Department</u>
Councilmember Einstein	<u>Building & Zoning Department</u>

And the following assignments are hereby approved and shall remain in effect for a period of six months, from September 2021 to February 2022:

Mayor Singer	<u>Finance Department</u>
Vice-Mayor Lusskin	<u>Building & Zoning Government</u>
Councilmember Bernstein	<u>Public Works Department</u>
Councilmember Mendal	<u>General Government</u>
Councilmember Einstein	<u>Police Department</u>

Section 3. Conflict. That all resolutions or parts of resolutions in conflict with this Resolution are hereby repealed to the extent of such conflict.

Section 4. Implementation. That the Mayor and Town Manager are authorized to take any and all action which is necessary to implement this Resolution.

Section 5. Effective Date. That this Resolution shall take effect immediately upon its adoption.

Sponsored by Town Administration.

The Motion to adopt the foregoing resolution was offered by _____, seconded by _____, and on roll call the following vote ensued:

Mayor Glenn Singer	_____
Vice Mayor Judy Lusskin	_____
Councilmember Kenneth Bernstein	_____
Councilmember Jaime Mendal	_____
Councilmember Bernard Einstein	_____

PASSED AND ADOPTED by the Town Council of the Town of Golden Beach, Florida,
this 16th day of February, 2021.

MAYOR GLENN SINGER

ATTEST:

LISSETTE PEREZ
TOWN CLERK

APPROVED AS TO FORM
AND LEGAL SUFFICIENCY

STEPHEN HELFMAN
TOWN ATTORNEY