

2 FOUNTAIN - Callout 1  
3/16" = 1'-0"

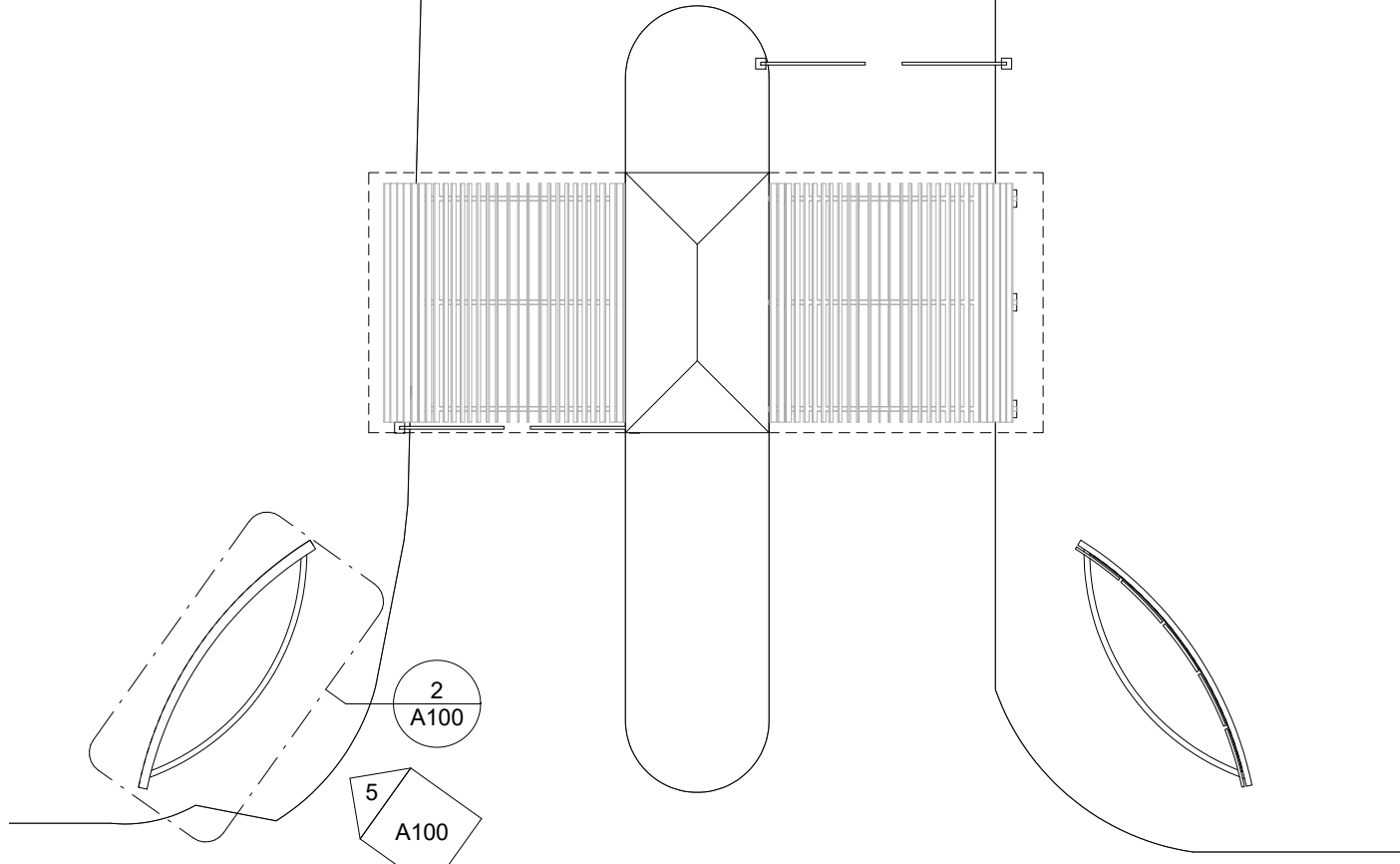

5 ELEVATION  
1/8" = 1'-0"



1 SUB-STATION SITE PLAN  
1" = 20'-0"

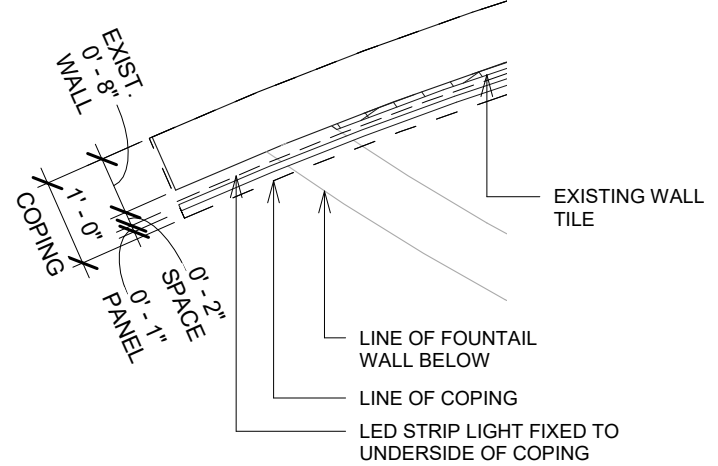

3 FOUNTAIN EDGE DETAIL  
1/2" = 1'-0"



3-FORM ACRYLIC PANEL CUSTOM PRINTED TRANSLUCENT PANEL TO MATCH PROPOSED CIVIC CENTER SCREENING



4 VIEW FROM OCEAN BLVD.  
12" = 1'-0"



TOWN OF GOLDEN BEACH  
www.goldenbeach.us  
(305) 932-0744

# TOWN ENTRY FOUNTAINS

## FOUNTIAN DESIGN

Project number	21-004	<b>A100</b>
Date	03/15/2021	
Drawn by	Author	Scale As indicated
Checked by	Checker	

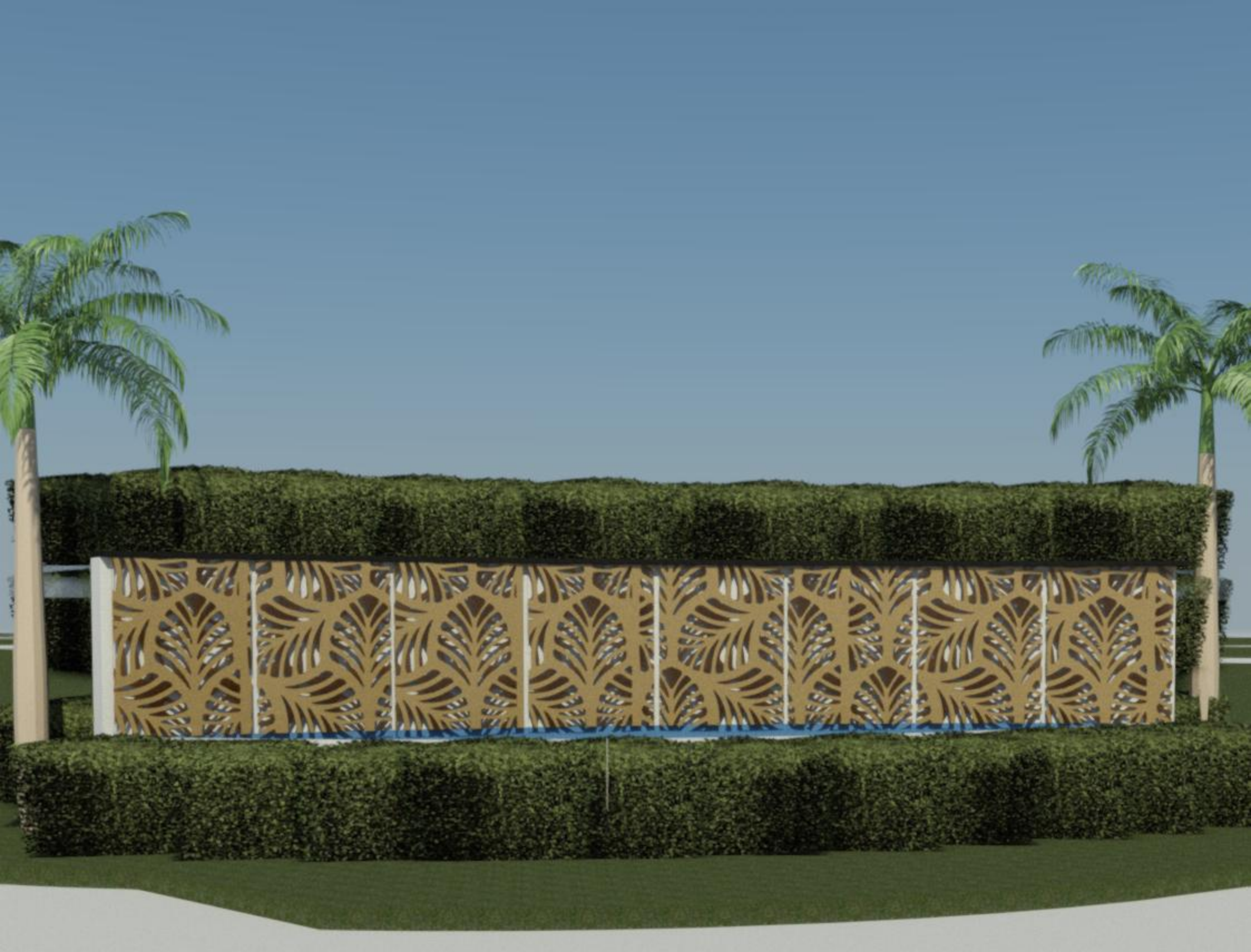





# TOWN OF GOLDEN BEACH

One Golden Beach Drive  
Golden Beach, FL 33160

---

## MEMORANDUM

---

**Date:** April 20, 2021

**To:** Honorable Mayor Glenn Singer &  
Town Council Members

**From:** Alexander Diaz,   
Town Manager

**Subject:** **Resolution No. 2742.21 – Authorizing the Town Attorney to Submit A Request to the Attorney General for Opinion Regarding Authorization to Impose a Special Assessment for Telecommunication Services**

Item Number:

9

---

### **Recommendation:**

It is recommended that the Town Council adopt the attached Resolution No. 2742.21 as presented.

### **Background:**

The Town has proposed providing high-speed fiber internet at a rate of 1 gig minimum to each home. In determining a responsible manner to fund this new service, we are exploring all of our options.

The attached resolution allows the Town to seek an Attorney General Opinion on one of the possible funding vehicles.

This, in no way binds the Town to using this funding source; it simply seeks clarity on possible funding opportunities.

### **Fiscal Impact:**

None

**TOWN OF GOLDEN BEACH, FLORIDA**

**RESOLUTION NO. 2742.21**

**A RESOLUTION OF THE TOWN COUNCIL OF THE TOWN OF GOLDEN BEACH, FLORIDA, AUTHORIZING THE TOWN ATTORNEY TO SUBMIT A REQUEST TO THE STATE OF FLORIDA ATTORNEY GENERAL FOR A FORMAL OPINION REGARDING THE AUTHORIZATION TO IMPOSE A SPECIAL ASSESSMENT FOR TELECOMMUNICATION SERVICES; AND PROVIDING FOR AN EFFECTIVE DATE.**

**WHEREAS**, the Town Council is considering the implementation of a special assessment to fund the provision of telecommunication services, including fiber optic internet service; and

**WHEREAS**, the Town Council recognizes that the authority to impose special assessments is by virtue of its home rule powers and by statute; and

**WHEREAS**, the Town Council desires the opinion of the Florida Attorney General on the extent of its statutory authority to impose a special assessment.

**NOW, THEREFORE, BE IT RESOLVED BY THE TOWN COUNCIL OF THE TOWN OF GOLDEN BEACH, FLORIDA, AS FOLLOWS:**

**Section 1. Recitals Adopted.** That each of the above stated recitals are hereby adopted, confirmed and incorporated herein.

**Section 2. Opinion Requested.** The Town Council hereby authorizes the Town Attorney to solicit from the Florida Attorney General a formal opinion substantially in the form and context attached hereto as Exhibit "A".

**Section 3. Effective Date.** That this Resolution shall be effective immediately upon adoption.

Sponsored by **Town Administration.**

The Motion to adopt the foregoing Resolution was offered by \_\_\_\_\_,  
seconded by \_\_\_\_\_ and on roll call the following vote ensued:

Mayor Glenn Singer	_____
Vice Mayor Judy Lusskin	_____
Councilmember Bernard Einstein	_____
Councilmember Jaime Mendal	_____
Councilmember Kenneth Bernstein	_____

PASSED AND ADOPTED by the Town Council of the Town of Golden Beach,  
Florida, this 20<sup>th</sup> day of April, 2021.

\_\_\_\_\_  
MAYOR GLENN SINGER

ATTEST:

\_\_\_\_\_  
LISSETTE PEREZ  
TOWN CLERK

APPROVED AS TO FORM  
AND LEGAL SUFFICIENCY:

\_\_\_\_\_  
STEPHEN J. HELFMAN  
TOWN ATTORNEY



# TOWN OF GOLDEN BEACH

One Golden Beach Drive  
Golden Beach, FL 33160

---

## MEMORANDUM

---

**Date:** April 20, 2021

**To:** Honorable Mayor Glenn Singer &  
Town Council Members

**From:** Alexander Diaz, *Alex B*  
Town Manager

**Subject:** **Resolution No. 2743.21 – Approving the amendment to the  
Design-Build Agreement**

Item Number:

10

---

### **Recommendation:**

It is recommended that the Town Council adopt the attached Resolution No. 2743.21 as presented.

### **Background:**

At the June 16<sup>th</sup>, 2020 Regular Town Council Meeting, via Resolution 2681.20 you approved the Design-Build agreement with Gerrits Construction, Inc. for the Town's Civic Center Complex, for an amount not to exceed \$5,588,761.00. Due to the impacts of the COVID-19 pandemic and the changing environment for new construction, new market requirements have greatly impacted the costs of construction materials. The project team has been working diligently over the past several months to navigate these changes alongside the contractor who has been evaluating multiple options for the Town.

Recent news reports from the Associated Builders & Contractors, confirm a steady increase in costs of commercial & industrial construction since June 2020. Since January 2021, construction input prices rose 4.8% from one year ago. Nonresidential construction input prices experienced a 4.2% increase over that span. Softwood lumber prices are up 73% on a year-over-year basis and iron and steel prices are up 15.6%. Natural gas prices have climbed 30% over the past year.

## Producer Price Index, January 2021

	1-Month % Change	12-Month % Change
Inputs to Construction	2.5%	4.8%
Inputs to Nonresidential Construction	2.1%	4.2%
Plumbing Fixtures and Fittings	-0.3%	1.8%
Fabricated Structural Metal Products	0.5%	3.2%
Iron and Steel	8.2%	15.6%
Steel Mill Products	5.2%	7.4%
Nonferrous Wire and Cable	2.3%	9.6%
Softwood Lumber	14.0%	73.0%
Concrete Products	-0.1%	1.7%
Prepared Asphalt, Tar Roofing & Siding Products	0.7%	2.9%
Crude Petroleum	12.0%	-10.5%
Natural Gas	-0.9%	30.0%
Unprocessed Energy Materials	5.3%	2.9%

Source: U.S. Bureau of Labor Statistics

Despite these challenges, we have been making progress to ensure that we will keep the project delivered by the end of 2022. Currently, the project is in the final stages of permitting and DERM approvals. We anticipate site mobilization and civil construction by the beginning of May 2021. Below find a list of project milestones.

DATE	MILESTONE
17-Jun 2020	Contract Award
23-Jul	30% CDs
26-Aug	60% CDs
16-Sep	Initial Structural Design
21-Sep	75% CDs
21-Sep	Civil Permit Submission to DERM
20-Oct	Ground Breaking Ceremony
20-Nov	100% Permit Set
18-Dec	Revised Structural Flooring System
07-Jan 2021	Revised construction timeline submitted by Gerrits
11-Jan	Revised Structural Permit Drawings
15-Jan	Site Construction Fencing installed
19-Jan	Golden Beach Review Complete - Rejected Structural Plans
20-Jan	Team meeting to discuss budget, COVID impacts & structural re-design
21-Jan	Team meeting with Golden Beach Building official ~ Structural Review
28-Jan	DERM approvals 75% complete
02-Feb	Revised budget received from Gerrits



MEMO RESO No. 2743.21

RE: Amending Design-Build Contract with Gerrits Construction, Inc.

11-Feb	Begin new final structural redesign
22-Feb	Notice to Proceed Issued
12-Mar	Complete structural redesign
04-May	Gerrits to begin civil site work
09-April	Revised budget received from Gerrits
20-April	Proposed Resolution to Amend the Design-Build Agreement
15-May	Gerrits to issue performance bond / Mobilize / Earthwork
17-May	Begin Pile Construction
08-June	Pour Pile Caps
Late 2022	Final inspections
Late 2022	Certificate of Occupancy ~ Project End

However, certain elements of the project agreement needs to be amended in order to move forward with the project. The market prices have drastically changed the original pricing of the Design-Build agreement. That being said, we have worked diligently with Gerrits Construction and we are confident that we have found a path forward.

We propose the Town amend the original contract price of \$5,588,761 to \$5,988,761, an increase of \$400,000. The additional funds reflect a shared burden by the Contractor and the Town for the soaring prices affecting the costs of goods and services created by the Global Pandemic.

Residents will not receive a special assessment or in any way be required to pay for the additional funding request, nor will this additional funding delay or cancel any additional Capital Projects the Town is considering.

We also propose extending the contract term by an additional 180 days. The global supply chain disruptions have caused major delays in securing goods and materials. This extension provides for a reasonable project completion timeline.

Once the contract has been amended, Gerrits Construction will have 30 calendar days to deliver the Builder Bond. In the two weeks following the amended contract, Gerrits must begin civil site work (May 4, 2021) and fulfill the terms of the contract.

**Fiscal Impact:**

A guaranteed amount not to exceed \$5,988,761.

The additional \$400,000.00 is funded as follows:

\$300,000.00 from the Fiscal Year 2020 Budget

\$100,000.00 from Code Violations collected in the 2021 budget

**TOWN OF GOLDEN BEACH, FLORIDA**

**RESOLUTION NO. 2743.21**

**A RESOLUTION OF THE TOWN COUNCIL OF THE TOWN OF GOLDEN BEACH, FLORIDA, APPROVING AN AMENDMENT TO THE DESIGN-BUILD AGREEMENT WITH GERRITS CONSTRUCTION, INC. FOR THE TOWN CENTER PROJECT; PROVIDING FOR CONDITIONS; PROVIDING FOR IMPLEMENTATION AND AN EFFECTIVE DATE.**

**WHEREAS**, on July 9, 2020, the Town of Golden Beach (the “Town”) entered into a Design-Build Construction Contract (the “Contract”) with Gerrits Construction, Inc. (“Gerrits”); and

**WHEREAS**, under the terms of the Contract, Gerrits is obligated to design and construct a new Town Center Project (the “Project”) for a Total Contract Price of \$5,588,761.00; and

**WHEREAS**, for various reasons the projected cost of the Project will exceed the Total Contract Price and Terms; and

**WHEREAS**, the Town and Gerrits have agreed to equitably absorb the additional cost of the Project and have therefore agreed to increase the Total Contract Price to \$5,988,761.00; and

**WHEREAS**, the contract will be extended by an additional 180 days; and

**WHEREAS**, the Town Council wishes to approve an amendment to the Contract and adopt this Resolution to reflect the agreed upon changes between the Town and Gerrits.

**NOW, THEREFORE, BE IT RESOLVED BY THE TOWN COUNCIL OF THE TOWN OF GOLDEN BEACH, FLORIDA, AS FOLLOWS:**

**Section 1. Recitals Adopted.** That each of the above stated recitals are hereby adopted, confirmed and incorporated herein.

**Section 2. Total Contract Price.** The Total Contract Price shall be increased to \$5,988,761.00.

**Section 3. Terms.** The Contract terms will be amended granting an additional 180 days for project completion.

**Section 4. Conditions.** The change to the Total Contract Price is subject to Gerrits delivering the original payment and performance bond(s) no later than May 30, 2021 and commencing the civil site work no later than May 4, 2021.

**Section 4. Implementation.** The Mayor is hereby authorized to execute an amendment to the Contract after approval by the Town Attorney reflecting the new Total Contract Price, and the Mayor and Town Manager are hereby authorized to take all steps reasonably necessary to implement the amendment to the Contract and this Resolution.

**Section 5. Effective Date.** That this Resolution shall be effective immediately upon adoption.

Sponsored by **Town Administration.**

[REMAINDER OF PAGE INTENTIONALLY LEFT BLANK]

The Motion to adopt the foregoing Resolution was offered by \_\_\_\_\_,  
seconded by \_\_\_\_\_ and on roll call the following vote ensued:

Mayor Glenn Singer	_____
Vice Mayor Judy Lusskin	_____
Councilmember Bernard Einstein	_____
Councilmember Jaime Mendal	_____
Councilmember Kenneth Bernstein	_____

PASSED AND ADOPTED by the Town Council of the Town of Golden Beach,  
Florida, this 20<sup>th</sup> day of April, 2021.

\_\_\_\_\_  
MAYOR GLENN SINGER

ATTEST:

\_\_\_\_\_  
LISSETTE PEREZ  
TOWN CLERK

APPROVED AS TO FORM  
AND LEGAL SUFFICIENCY:

\_\_\_\_\_  
STEPHEN J. HELFMAN  
TOWN ATTORNEY