

TOWN OF GOLDEN BEACH  
BUILDING AND ZONING DEPARTMENT  
MEMORANDUM

---



**TO:** Building Regulatory Advisory Board  
**FROM:** Christopher M. Gratz, AICP, Consulting Planner  
**DATE:** January 10<sup>th</sup>, 2023  
**SUBJECT:** Variance, 194 South Island Drive

---

**GENERAL PROPERTY INFORMATION**

**Land Use Designation:** Low Density Residential  
**Zoning District:** Zone Three (3)  
**Address:** 194 South Island Drive  
**Legal Description:** Lot 26 and the south 35' of Lot 27, Block "J", Section "D" of Golden Beach, According to the Plat thereof, as recorded in Plat Book 10, Page 10 of the Public Records of Miami-Dade County.  
**Lot Information:** Under-sized lot, 85' wide, 165' deep, 14,025 square feet (0.32 acres)

---

**APPLICATION INFORMATION**

**Owner/Applicant:** Michael and Michelle Klinger/ Elite Environmental Permitting Services, Tabatha Tolley

---

**REQUEST**

Variance **FROM:** Town Code §46-81 which does not allow any part of seawalls, including slabs, to extend beyond any lot property line into any waterway in the Town and requires that during the construction of a new seawall or renovation of an existing seawall if it is found that portions of the existing seawall encroach into a public waterway adjoining a lot, those portions of the seawall encroachment shall be modified or removed, unless a Variance is granted by the Town;

**TO:** allow the existing seawall to remain encroaching into a Town waterway by 1'- 8 ¾ (total of 147 sq. ft. of the Town's submerged land); approximately 1 ¼" of the 2' wide seawall was constructed on the property.

---

## HISTORY

A 2-story 7,058 sq. ft. home approved by the BRAB on 9/14/2021 is under construction. Information as to when the existing seawall was constructed was not provided. Town Code §46-86(b)(2) requires that all nonconforming seawalls be replaced entirely on the property when the primary structure is demolished.

---

## APPLICATION DETAILS

The applicant is proposing to:

- Remove the existing wood dock and piles; wood mooring piles.
- Raise the seawall from 3.04' to 4.425' NAVD
- Install a 57'-6" x 6' wood dock, 24,000 lb. boatlift, and 1,500 lb. jet ski lift

All aspects of the proposed new structures are compliant; the only issue is the seawall encroachment.

---

## ANALYSIS

### DIVISION 2. - VARIANCES

#### §66-41. - Authorized, general procedure.

(a) The Building Regulation Advisory Board may recommend pursuant to the hearing as provided in §66-42 the granting of a Variance by the Town Council from the terms of the zoning provision of this chapter if it is not contrary to the public interest where, owing to special conditions, a literal enforcement of the provisions will result in unnecessary and undue hardship. In order to recommend any Variance from the terms of this chapter, the Board shall find the following:

- (1) The Variance is in fact a Variance from a zoning regulation as set forth within this chapter.

***The request is for a variance from zoning regulation.***

- (2) Special conditions and circumstances exist which are peculiar to the land or structure involved and which are not applicable to other lands or structures in the same district.

***This property is in Zone 3 and the Town's requirement that seawalls not encroach into the Town's waterway is applicable to all properties.***

- (3) The special conditions and circumstances do not result from the actions of the applicant.

***The variance request is a direct result of the applicant's desire to leave the existing encroaching seawall in place.***

(4) Granting the Variance requested will not confer on the applicant any special privilege that is denied by this chapter to other lands or structures in the same district.

***The Town Code does not allow encroachments into its waterways unless a variance is granted. Granting the variance will give the owner the privilege to occupy approximately 147 square feet of submerged land.***

(5) Literal interpretation of the provisions of this chapter would deprive the applicant of rights commonly enjoyed by other properties in the same district under the terms of zoning regulations and would work unnecessary and undue hardship on the applicant.

***No owners have the right to have a seawall encroach into the Town's waterway.***

(6) The Variance granted is the minimum Variance that will make possible the reasonable use of the land or structure.

***The requested is variance minimum the applicant needs to avoid reconstructing the seawall in the correct location. No evidence has been presented that reconstructing the seawall within the property lines as required is not possible.***

(7) The granting of the Variance will be in harmony with the general intent and purpose of this chapter and the Variance will not be injurious to the area involved or otherwise detrimental to the public welfare.

***The intent of the Town Code is to promote the construction of luxury homes; consistency in the placement of seawalls is an inherent quality of a luxury home community. The survey shows the seawall is in alignment with the neighboring seawalls.***

(b) In recommending the granting of any Variance, the Building Regulation Advisory Board may prescribe appropriate conditions and safeguards in conformity with this Code. Violation of the conditions and safeguards, when made a part of the terms under which the Variance is granted, shall be deemed a violation of the Code of Ordinances. The Building Regulation Advisory Board may prescribe a reasonable time limit wherein the Construction of the structure subject to the Variance is required to be completed.

***No conditions are recommended.***

(c) Under no circumstances shall the Building Regulation Advisory Board recommend the granting of a Variance or a use not generally permitted in the district involved or any use expressly or by implication prohibited by the terms of this Code in the district. No nonconforming use of neighboring lands, structures or buildings in the same district and no permitted use of lands, structures or buildings in other districts shall be considered grounds for a Variance.

*The property survey shows that the seawall is aligned with the neighboring properties.*

---

**RECOMMENDATION**

The applicant has failed to provide any substantial competent evidence to support the request and fails to meet the criteria required by the Town Code for the granting of a variance; therefore **denial** of the application is recommended.



## TOWN OF GOLDEN BEACH NOTICE OF PUBLIC HEARING

The **BUILDING ADVISORY BOARD** and the **TOWN COUNCIL** of the **TOWN OF GOLDEN BEACH** will hold a Public hearing on the following proposal:

  X   Variance Request(s)  
       Accessory Structures

Construction of a new seawall, dock and installation of a Boat Lift.

Relief from Town Code Sec. 46-81. - Extension of seawall into waterways.

No part of any seawall, including slabs may extend beyond any lot property line into any waterway in the Town. The piles and cap beam may encroach into the waterway, if approved by the agency having jurisdiction.

Request is to allow the new seawall cap and panels to encroach outside the property line into the waterway at various depths along the seawall.

JOB ADDRESS:	194 South Island Dr., Golden Beach, FL.
OWNER ADDRESS:	194 South Island Dr., Golden Beach, FL.
REQUESTED BY:	Michael G. and Michelle Frohlich Klinger
LEGAL DESCRIPTION:	Lot 26, & s 35' of Lot 27, Block J, GB Sect D, PB 10-10
FOLIO NO.:	19-1235-004-0850

The **BUILDING ADVISORY BOARD** will consider this item:

GOLDEN BEACH TOWN HALL  
1 GOLDEN BEACH DR., GOLDEN BEACH, FL.  
January 10, 2023 at 6pm  
<https://us02web.zoom.us/j/89291108015?pwd=NS8rWnJhN21mSUdlcmFadHErei8yZz09>  
Meeting ID: 892 9110 8015  
Passcode: 752288

The **TOWN COUNCIL** will consider this item:

GOLDEN BEACH TOWN HALL  
1 GOLDEN BEACH DR., GOLDEN BEACH, FL.  
January 17, 2023 at 6pm

If you wish to submit written comments for consideration, they should be submitted to the Office of the Golden Beach Town Manager, prior to the scheduled meeting. If you have any questions regarding the proposed action, you may contact the Building Department at (305) 932-0744

DATED: December 15, 2022

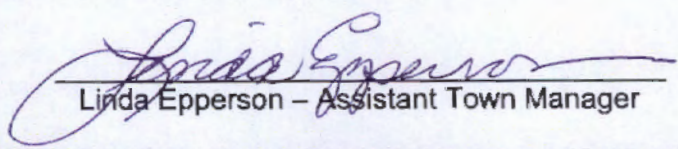
  
Linda Epperson – Assistant Town Manager

PURSUANT TO FLA. STATUTE 286.0105, THE TOWN HEREBY ADVISES THE PUBLIC THAT: IF A PERSON DECIDES TO APPEAL ANY DECISION MADE BY THE COUNCIL, BOARD OR COMMITTEE WITH RESPECT TO ANY MATTER CONSIDERED AT ITS MEETING OR HEARING, HE WILL NEED A RECORD OF THE PROCEEDINGS, AND THAT FOR SUCH PURPOSE, AFFECTED PERSONS MAY NEED TO ENSURE THAT A VERBATIM RECORD OF THE PROCEEDING IS MADE, WHICH RECORD INCLUDES THE TESTIMONY AND EVIDENCE UPON WHICH THE APPEAL IS TO BE BASED. ANY INDIVIDUAL WHO BELIEVES HE OR SHE HAS A DISABILITY WHICH REQUIRES A REASONABLE ACCOMMODATION IN ORDER TO PARTICIPATE FULLY AND EFFECTIVELY IN A MEETING OF THE BUILDING REGULATION BOARD MUST SO NOTIFY THE TOWN CLERK, AT (305) 932-0744 AT LEAST 24 HOURS PRIOR TO THE DATE OF THE MEETING.

TOWN OF GOLDEN BEACH  
APPLICATION FOR  
BUILDING REGULATION ADVISORY BOARD HEARING

JAN 11 2023

Request hearing in reference to: Application fee: 750  
DISAPPROVED  
VARIANCE REQ

New residence/addition: \_\_\_\_\_ Variance(s): Raising seawall outside property line  
Exterior alterations: \_\_\_\_\_ Other Structure: \_\_\_\_\_  
Date application filed: 11/21/2022 For hearing date: 1/10/23

1. Project information:

Project description: Construction of a new two-story 7,058 square foot residence with pool, gazebo, dock, boat lift, seawall raise, and side/front property walls.

Legal Description: GOLDEN BEACH SEC D PB 10-10 LOT 26 & S35 FT OF LOT 27, BLK J  
OR 13484-0661 1187 1, COC 21713-1922 09 2003 1

Folio #: 19-1235-004-0650

Address of Property: 194 S Island Drive

2. Is a variance(s) required: Yes  No  How Many? 1  
(If yes, please submit variance application form for each request).

Owner's Name: MICHAEL KLINGER Phone (305) 968-4466 Fax \_\_\_\_\_

Owner's address: 194 S Island Drive City/State Golden Beach Zip 33160

Email address: klinger@saberfund.com

Agent: Elite Environmental Permitting Services, Tabatha Tolley Phone (772) 834-5117 Fax \_\_\_\_\_

Agent's address: 5050 Ben Eden Lane City/State West Palm Beach Zip 33415

Email address: tolley.tabatha@yahoo.com

Architect: NMD Nomadas, LLC / Farid Chacon Phone (954) 658-5852 Fax \_\_\_\_\_

Email address: faridchacon@nomadas.net

Contractor: Southeast Marine Construction Phone (305) 216-4320 Fax \_\_\_\_\_

3. Describe project and/ or reason for hearing request: Overpour new seawall cap,  
24k Boat lift and 1,500# jet ski lift to be installed on a New 57'-6" x 6' Wood Dock With (8) concrete dock Support piles.  
Variance request results from the existing seawall encroaching 1' 8 3/4" outside of the property line and Town Code §46-86(b)  
requires that all nonconforming seawalls replaced entirely on the subject property unless a variance is granted per Town Code §46-81

4. The following information is submitted for assisting in review:

Building Plans:

Conceptual:  Preliminary:  Final:   
Other: \_\_\_\_\_

5. Estimated cost of work: \$ 100,780  
Estimated market value of: Land \$ 2,945,250.00  
Building \$ 2,470,000.00

(Note: If estimated cost of work is 40% of the market value of the building an independent appraisal is required).

TOWN OF GOLDEN BEACH  
APPLICATION FOR  
BUILDING REGULATION ADVISORY BOARD HEARING

6. Is hearing being requested as a result of a Notice of Violation? No
7. Are there any structures on the property that will be demolished? Yes, existing dock/piles
8. Does legal description conform to plat? Yes
9. Owner Certification: I hereby certify that I am the owner of record (\*) of the property described in this application and that all information supplied herein is true and correct to the best of my knowledge.

Signature of owner(s): M. Kl.

Acknowledged before me this 15<sup>th</sup> day of November 2022

Type of identification:

Personally known

Notary Public



ANA M. FREEDMAN  
Commission # HH 229002  
Expires March 6, 2026

Owner/Power of Attorney Affidavit:

I, being duly sworn, depose and say I am the owner (\*) of the property described in this application and that I am aware of the nature and request for: a variance  
relative to my property and I am hereby authorizing Tabatha Tolley to be my legal representative before the Building Regulation Advisory Board and Town Council.

M. Kl.  
Signature of owner(s)

Acknowledged before me this 15<sup>th</sup> day November 20 22

Type of identification:

Personally known

Notary Public

(\*) If owner of record is a corporation then the president with corporate seal, the president and the secretary (without corporate seal), or duly authorized agent for the corporation may execute the application, proof that the corporation is a corporation in good standing.



ANA M. FREEDMAN  
Commission # HH 229002  
Expires March 6, 2026

TOWN OF GOLDEN BEACH  
APPLICATION FOR  
BUILDING REGULATION ADVISORY BOARD HEARING

Property Address: 194 S Island Drive  
 Legal Description: GOLDEN BEACH SEC D PB 10-10 LOT 26 & S35 FT OF LOT 27, BLK J  
 Owner's Name: Michael Klinger Phone (305) 968-4468 Fax \_\_\_\_\_  
 Agent's Name: Tabatha Tolley Phone (772) 834-5117 Fax \_\_\_\_\_  
 Board Meeting of: 1/10/23

- NOTE: 1. Incomplete applications will not be processed.  
 2. Applicant and/or architect must be present at meeting.

Application for: Variance for encroachment of seawall outside of property line  
 Lot size: 14,025  
 Lot area: 14,025  
 Frontage: 85  
 Construction Zone: AE7  
 Front setback: 35  
 Side setback: 10  
 Rear setback: 35  
 Coastal Construction: Yes  No  East of coastal const. control line: Yes  No   
 State Road A1A frontage: N/A  
 Swimming pool:  Yes  No Existing: \_\_\_\_\_ Proposed: YES  
 Fence Type: MASONRY BLOCK Existing: \_\_\_\_\_ Proposed: YES  
 Finished Floor elevation N.G.V.D.: 9.60  
 Seawall: PLAN TO RAISE THE SEAWALL TO 4.425' NAVD Existing: YES AT 3.05' NAVD Proposed: YES AT 4.425' NAVD  
 Lot Drainage: Rainwater will be disposed of in a proposed exfiltration trench system  
 How will rainwater be disposed of on site? Rainwater will be disposed of in a proposed exfiltration trench system

Adjacent use (s): SINGLE FAMILY HOMES  
 Impervious area: 9,098.61  
 % of impervious area: 64.87%  
 Existing ground floor livable area square footage: 3,988 SF  
 Proposed ground floor livable area square footage: 3,611.2 SF  
 Existing 2<sup>nd</sup> floor livable area square footage: 2,815 SF  
 Proposed 2<sup>nd</sup> floor livable area square footage: 3,447.64 SF  
 Proposed % of 2<sup>nd</sup> floor over ground floor: 95.47%  
 Vaulted area square footage: N/A  
 Vaulted height: N/A  
 Color of main structure: Light beige / Off-white  
 Color of trim: Bronze and Wood Tones  
 Color & material of roof: Membrane Roofing EPDM High Albedo  
 Building height (above finished floor elevation): 25' above first floor elevation  
 Swale: (Mandatory 10'-0" from edge of payment, 10 ft. wide x 1 ft. deep minimum):

Existing trees in Lot: 38 trees, 4 palms in Swale: 19  
 Proposed trees in Lot: 17 in Swale: 3  
 Number & type of shrubs: 722  
 Garage Type: Attached - Two Car Garage Existing: N/A Proposed: Attached Two Car Garage  
 Driveway width & type: 12' width paver over structured slab on piles

Signature of Applicant:  Date: 1/15/22



TOWN OF GOLDEN BEACH  
BUILDING REGULATION ADVISORY BOARD  
APPLICATION FOR  
PETITION FOR VARIANCE

Date: 11/15/22

Fee: 750.00

I, Michael Klinger hereby petition the Town of Golden Beach for a variance from the terms of the Town of Golden Beach Code of Ordinances affecting property located at: 194 S. Island Drive Folio No. 19-1235-004-0650

As specified in the attached "Application for Building Regulation Advisory Board" and related supporting material.

1. The Variance requested is for relief from the provisions of **(list section number(s) of the Town of Golden Beach Code of Ordinances)**: \_\_\_\_\_

Variance request results from the existing seawall encroaching 1' 8 3/4" outside of the property line and Town Code §46-86(b) requires that all nonconforming seawalls replaced entirely on the subject property unless a variance is granted per Town Code §46-81

2. In order to recommend the granting of the variance, it must meet all the following criteria (please provide a response to each item):

a. The Variance is in fact a Variance from a zoning regulation as set forth within the Zoning Chapter of the Town Code. Confirmed. Town Code §46-86(b) requires that all nonconforming seawalls replaced entirely on the subject property.

b. Special conditions and circumstances exist which are peculiar to the land or structure involved, and which are not applicable to other lands or structures in the same district. The previous seawall was built in its current place. We are raising the seawall cap pursuant to town code on the same footprint as the current seawall.

c. The special conditions and circumstances do not result from the actions of the applicant. Confirmed. Current owner purchased the property in November 2021 and the seawall/dock has not be changed.

d. Granting the Variance requested will not confer on the applicant any special privilege that is denied by the Zoning Chapter of the Town Code to other lands or structures in the same district. Confirmed

TOWN OF GOLDEN BEACH  
BUILDING REGULATION ADVISORY BOARD  
PETITION FOR VARIANCE

3. Literal interpretations of the provisions of the Zoning Chapter of the Town Code would deprive the applicant of rights commonly enjoyed by other properties in the same district under the terms of zoning regulations and would work unnecessary and undue hardship on the applicant. Confirmed. Tearing down the seawall altogether is unnecessary as it is in fine condition.  
Applicant is looking to comply with code which calls for the seawall to be raised to 4.425' NAVD.

4. The Variance granted is the minimum Variance that will make possible the reasonable use of the land or structure. Confirmed. We are replacing the existing seawall footprint

5. The granting of the Variance will be in harmony with the general intent and purpose of the Town Code and the Variance will not be injurious to the area involved or otherwise detrimental to the public welfare. Confirmed

Does the Variance being requested comply with all the above listed criteria?  
 Yes  No

6. Our code states that submission of a written statement is invited and encouraged. Has the applicant (petitioner) explained the variance to the owners of the nearest adjacent residences and sought their approval in writing? Yes  No   
Please attach any written letters of no objection to this petition.

7. Is this request related to new construction?  Yes  No

8. Is construction in progress? Yes, a house. But no machine construction

9. Is this request as a result of a code violation? No

10. Did this condition exist at the time property was acquired?  Yes  No

11. Is this request sought as a remedy to a case to be heard, or action taken by the Special Magistrate? No

12. Do you have a building permit?  Yes  No

Building Permit No. B-22-04-11692(SFR) Date issued: 4/13/22

TOWN OF GOLDEN BEACH  
BUILDING REGULATION ADVISORY BOARD  
PETITION FOR VARIANCE  
AFFIDAVIT BY OWNER

Affidavit by Owner for Variance Request(s):

Folio No.: 19-1235-004-0650 Address: 194 S. Island Dr.

Legal Description: GOLDEN BEACH SEC D PB 10-10 LOT 26 & S35 FT OF LOT 27, BLK J  
OR 13484-0661 1187 1, COC 21713-1922 09 2003 1

Being duly sworn, deposes and says: That He/She is the Owner named in the application for Building Advisory Board for the hearing date of 1/10/23 relating to Variance requests for construction or other work to be performed on, or in connection with, the premises located as indicated in the application.

I acknowledge notification by The Town of Golden Beach, that granting of a variance(s) by The Town Council, is conditioned on the following:

1. That a Building Permit for the contemplated work pursuant to the Variance must be issued within two (2) years from the date of the approval of the Resolution granting such variance request.
2. If a Building Permit is not issued within the two (2) year time limit set then the Resolution granting the Variance approval will be null and void.
3. That as the applicant, and at my own expense, I shall record a certified copy of the Resolution in the public records of Miami-Dade County and return two (2) certified copies to the Golden Beach Town Hall for inclusion into my property records.

M. KL

Signature of Owner or Legal Representative

Sworn to and subscribed before me this 15<sup>th</sup> day of November, 2022

[Signature]

Notary Public State of Florida at Large

Personally know to me

Produced Identification



ANA M. FREEDMAN  
Commission # HH 229002  
Expires March 6, 2026

TOWN OF GOLDEN BEACH  
ACKNOWLEDGEMENT and AFFIDAVIT BY OWNER  
Chapter 46-85 Height of Seawalls and Docks and Extension of Deck of Dock.  
of the Code of Ordinances  
Article IV Seawalls and Docks.

Affidavit by Owner: MICHAEL KLINGER

Folio No.: 19-1235-004-0650 Address: 194 S ISLAND DRIVE

Legal Description: GOLDEN BEACH SEC D PB 10-10 LOT 26 & S35 FT OF LOT 27, BLK  
J OR 13484-0661 1187 1, COC 21713-1922 09 2003 1

Being duly sworn, deposes and says: That He/She is the Owner named in the permit application for construction or other related work to be performed on, or in connection with, the premises, as indicated above, and is in agreement that granting of a permit for construction on said premises, agrees to repair, or replace said seawall in question, to a conforming minimum 3.425 feet above NAVD-88 or to a maximum 4.425 feet NAVD-88 elevation and to replace/and or repair any deteriorated seawall or portion thereof, as required by the Town's Code of Ordinances, Article IV "Seawalls and Docks, The Miami Dade County DERM Division, State of Florida DEP Coastal Division, the Army Corp of Engineers (if applicable) and the current Florida Building Code.

*M. Klinger*

Signature of Owner or Legal Representative  
Print Name: Michael Klinger

Sworn to and subscribed before me this 15<sup>th</sup> day of November 20 22

*[Signature]*  
Notary Public State of Florida at Large

Personally know to me

Produced Identification



**ANA M. FREEDMAN**  
Commission # HH 229002  
Expires March 8, 2028

Property Information  
 Folio: 19-1235-004-0650  
 Sub-Division:  
 GOLDEN BEACH SEC D  
 Property Address  
 194 S ISLAND DR  
 Owner  
 MICHAEL G KLINGER  
 MICHELLE FROHLICH KLINGER  
 Mailing Address  
 194 S ISLAND DR  
 GOLDEN BEACH, FL 33160  
 PA Primary Zone  
 1300 SGL FAMILY - 2801-3000 SQ

Full Legal Description  
 GOLDEN BEACH SEC D PB 10-10  
 LOT 26 &  
 S35FT OF LOT 27 BLK J  
 LOT SIZE 85.000 X 165  
 OR 13484-0661 1187 1  
 COC 21713-1922 09 2003 1

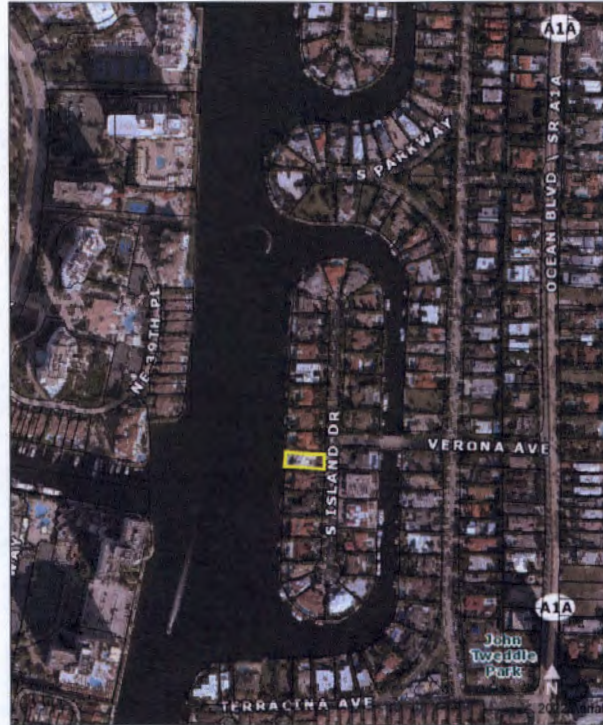

LOCATION MAP  
 Town of Golden Beach  
 Building Regulatory Advisory Board  
 Hearing Date

JAN 11 2023

"This document has been electronically signed and sealed by John H. Omslaer, P.E. on date noted using a SHA-1 authentication code. Printed copies are not considered signed and sealed and the SHA-1 authentication code must be verified on any electronic copies per Rule 62-30.060, F.A.C."

JOHN H. OMSLAER P.E. Date:  
 Reg. Florida No. 52733

APPROVED \_\_\_\_\_  
 DISAPPROVED \_\_\_\_\_  
 VARIANCE REQ \_\_\_\_\_

DYNAMIC ENGINEERING SOLUTIONS  
 1950 N.E. 6th Street #10075  
 Pompano Beach, FL 33061  
 Phone - 954-860-5262  
 Email - des\_inc@bellsouth.net  
 E.B. # 26829

PROJECT NAME: **KLINGER RESIDENCE**  
 194 S ISLAND DR  
 GOLDEN BEACH, FL 33160

NEW CONCRETE SEAWALL CAP & NEW WOOD DOCK  
 W/24,000# CAPACITY BOAT LIFT & PWC-JET SKI LIFT

Elite Environmental  
 Permitting Service  
 234 Parkway Court  
 Greenacres Florida 33413  
 OFFICE: 772-834-5117  
 E-Mail tolley.tabatha@yahoo.com

DATE: 04/28/2022  
 REVIEWER: D  
 11/30/2022  
 S-1

**GENERAL NOTES**

**GENERAL**

ALL DIMENSIONS ON PLANS ARE SUBJECT TO VERIFICATION IN THE FIELD. IT IS THE INTENT OF THESE PLANS TO BE IN ACCORDANCE WITH APPLICABLE CODES AND AUTHORITIES HAVING JURISDICTION. ANY DISCREPANCIES BETWEEN THESE PLANS AND APPLICABLE CODES SHALL BE IMMEDIATELY BROUGHT TO THE ATTENTION OF THE ENGINEER BEFORE PROCEEDING WITH WORK.

IT IS THE INTENT OF THESE PLANS AND THE RESPONSIBILITY OF THE CONTRACTOR TO COMPLY WITH LOCAL, STATE AND FEDERAL ENVIRONMENTAL AND BUILDING PERMIT ISSUED FOR THIS PROJECT. IT SHALL BE THE CONTRACTORS RESPONSIBILITY TO FAMILIARIZE AND GOVERN HIMSELF BY ALL PROVISIONS OF THESE PERMITS.

THE WORK SPECIFIED HEREIN HAS BEEN DESIGNED & ALL WORK SHALL BE IN ACCORDANCE WITH STRUCTURAL PROVISIONS OF THE 7TH EDITION 2020 FLORIDA BUILDING CODE.

**CONCRETE**

1. ALL CONCRETE (EXCEPT PRECAST PILES) SHALL ATTAIN A MINIMUM COMPRESSIVE STRENGTH OF 5,000 PSI. AT THE END 0-28 DAYS, FOUR (4) CONCRETE CYLINDERS SHALL BE TAKEN FOR EACH 50 CUBIC YARD OR FRACTION THEREOF AND SHALL BE TESTED AT 3.7 & 28 DAYS. SLUMP SHALL NOT EXCEED 4" (±1") MAX W/C RATIO+0.40.
2. ALL REINFORCEMENT SHALL BE 60,000 PSI MINIMUM YIELD NEW BILLET STEEL IN ACCORDANCE WITH ASTM A615 GRADE 60. ALL BAR LAPS SHALL BE A MINIMUM OF 36 BAR DIAMETERS, PLACING OF REINFORCEMENT SHALL CONFORM TO THE LATEST ACI CODE AND MANUAL OF STANDARD PRACTICE.
3. ALL CONCRETE SHALL BE PLACED WITHIN 90 MINUTES FROM BATCH TIME, AND VIBRATED AS REQUIRED BY THE ACI MANUAL OF CONCRETE PRACTICE. TEMPERATURE OF CONCRETE AT TIME OF PLACEMENT SHALL BE BETWEEN 75° AND 100°F.
4. ALL CONCRETE DECK SURFACES SHALL HAVE A LIGHT BROOM FINISH.
5. ALL EXPOSED CONCRETE EDGES SHALL BE CHAMFERED 3/4" OR AS SHOWN ON THE PLANS.

**WOOD**

1. PRIMARY WOOD FRAMING MEMBERS SHALL BE NO. 2 PRESSURE TREATED SOUTHERN PINE OR BETTER. (FB=1050 PSI MINIMUM)

**HARDWARE**

1. ALL MISCELLANEOUS STEEL COMPONENTS, BOLTS AND HARDWARE SHALL BE TYPE 316 STAINLESS STEEL UNLESS OTHERWISE SPECIFIED ON PLANS.

**PILE NOTES:**

**12"x12" PRECAST CONCRETE PILES:**

- 5000-PSI MIN. CONCRETE w/ (4) #6 DIA. 270-KSI ASTM A416 LOW-LAX STRANDS.
- MINIMUM PILE LENGTH=34' BELOW EXISTING STREET LEVEL OR REFUSAL
- PILE CAPACITY COMPRESSION / TENSION / LATERAL (TONS): 25 / 7 / 1

**12" DIA. WOOD PILES:**

- SOUTHERN PILE PER ASTM D25 TREATED FOR MARINE: SALTWATER PER TIMBER PILING COUNCIL.
- MINIMUM PILE LENGTH=34' BELOW EXISTING STREET LEVEL OR REFUSAL
- PILE CAPACITY COMPRESSION / TENSION / LATERAL (TONS): 15 / 5 / 1

**MISCELLANEOUS**

1. FASTENERS EMBEDDED INTO CONCRETE STRUCTURES SHALL BE ANCHORED WITH TWO-PART EPOXY ADHESIVE (RAWL® CHEM-FAST CARRIDGE SYSTEM OR EQUAL). ANCHOR HOLES SHALL BE DRILLED TO 1/8" GREATER THAN THE SPECIFIED FASTENER SIZE. HOLES SHALL BE DRILLED TO A MINIMUM DEPTH SHOWN ON THE PLANS & SHALL BE THOROUGHLY CLEANED OUT AND DRY PRIOR TO INJECTION OF EPOXY.

**LOADS**

LL = 60 PSF DL = 10 PSF

**TURBIDITY BARRIER**

APPROVED TURBIDITY BARRIERS SHALL REMAIN IN PLACE DURING ALL PHASES OF IN WATER CONSTRUCTION.

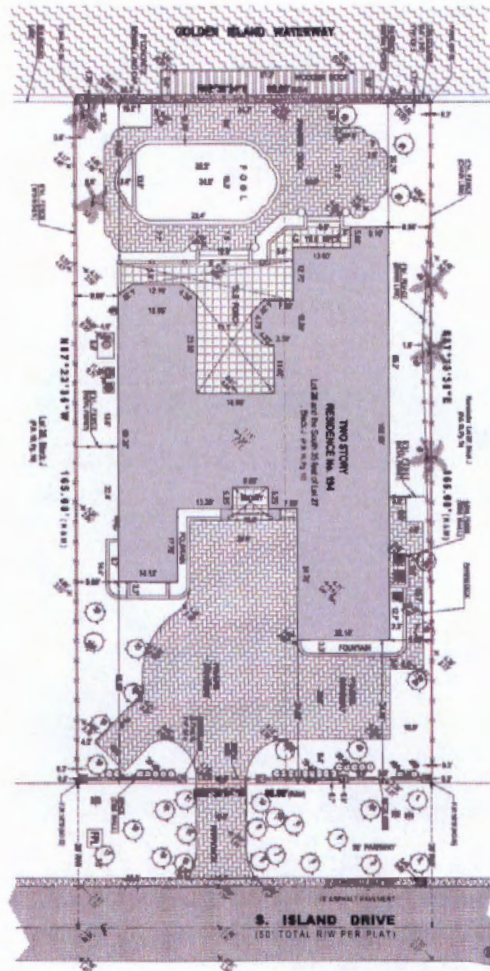

Town of Golden Beach  
 Building Regulatory Advisory Board  
 Hearing Date

JAN 11 2023

APPROVED \_\_\_\_\_  
 DISAPPROVED \_\_\_\_\_  
 VARIANCE REQ \_\_\_\_\_

"This document has been electronically signed and sealed by John H. Omslaer, P.E. on date noted using a SHA-1 authentication code. Printed copies are not considered signed and sealed and the SHA-1 authentication code must be verified on any electronic copies per Rule 62-30.060, F.A.C."

JOHN H. OMSLAER P.E. Date:  
 Reg. Florida No. 52733

COPY OF BOUNDARY SURVEY  
 SCALE 1"=30'

DYNAMIC ENGINEERING SOLUTIONS  
 1950 N.E. 6th Street #10075  
 Pompano Beach, FL 33061  
 Phone - 954-860-5262  
 Email - des\_inc@bellsouth.net  
 E.B. # 26829

**KLINGER RESIDENCE**  
 194 S ISLAND DR  
 GOLDEN BEACH, FL 33160

NEW CONCRETE SEAWALL CAP & NEW WOOD DOCK  
 W/24,000# CAPACITY BOAT LIFT & PWC-JET SKI LIFT

Elite Environmental  
 Permitting Service  
 234 Parkway Court  
 Greenacres Florida 33413  
 OFFICE: 772-834-5117  
 E-Mail tolley.tabatha@yahoo.com

DATE 04/28/2022  
 REVIEWER D  
 11/30/2022

S-2

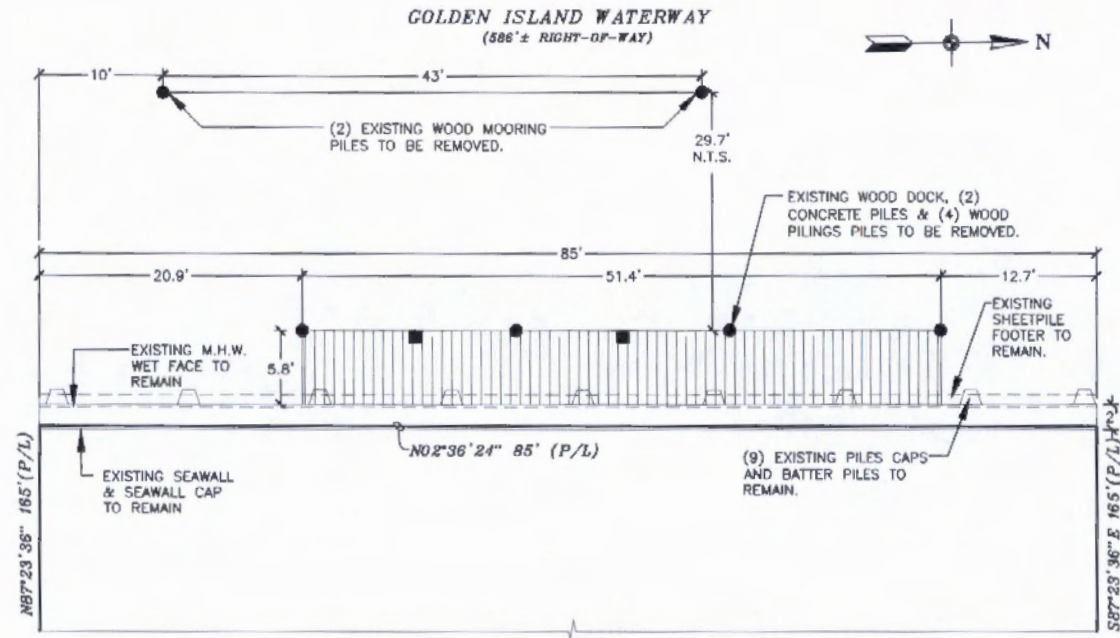

Town of Golden Beach  
Building Regulatory Advisory Board  
Hearing Date

JAN 11 2023

"This document has been electronically signed and sealed by John H. Omslaer, P.E. on date noted using a SHA-1 authentication code. Printed copies are not considered signed and sealed and the SHA-1 authentication code must be verified on any electronic copies per Rule 62-30.060, F.A.C."

JOHN H. OMSLAER P.E. Date:  
Reg. Florida No. 52733

EXISTING CONDITION  
SCALE 1"=10'

APPROVED \_\_\_\_\_  
DISAPPROVED \_\_\_\_\_  
VARIANCE REQ \_\_\_\_\_

DYNAMIC ENGINEERING SOLUTIONS  
1950 N.E. 6th Street #10075  
Pompano Beach, FL 33061  
Phone - 954-860-5262  
Email - des\_inc@bellsouth.net  
E.B. # 26829

**KLINGER RESIDENCE**  
194 S ISLAND DR  
GOLDEN BEACH, FL 33160

NEW CONCRETE SEAWALL CAP & NEW WOOD DOCK  
W/24,000# CAPACITY BOAT LIFT & PWC-JET SKI LIFT

Elite Environmental  
Permitting Service  
234 Parkway Court  
Greenacres Florida 33413  
OFFICE: 772-834-5117  
E-Mail toley.tabatha@yahoo.com

DATE: 04/28/2022  
REVISION: D  
11/30/2022  
S-3

NOTE:

64'-4"x-5'-6"=354 SF WOOD DOCK OVER WATER  
 1'-4"x85'=113.3 SF SEAWALL CAP OVER WATER  
 TOTAL OVER WATER 354+113.3=467.3 SF

GOLDEN ISLAND WATERWAY  
 (000's RIGHT-OF-WAY)

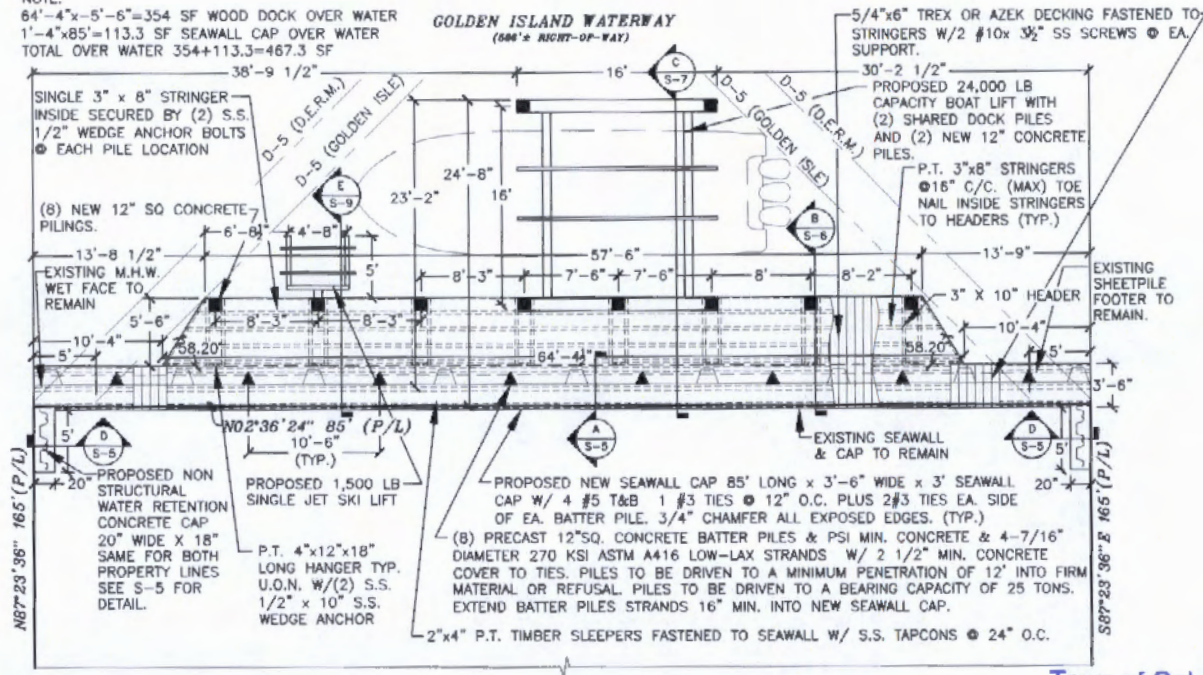

Town of Golden Beach  
 Building Regulatory Advisory Board  
 Hearing Date

JAN 11 2023

"This document has been electronically signed and sealed by John H. Omslaer, P.E. on date noted using a SHA-1 authentication code. Printed copies are not considered signed and sealed and the SHA-1 authentication code must be verified on any electronic copies per Rule 62-30.060, F.A.C."

JOHN H. OMSLAER P.E. Date:  
 Reg. Florida No. 52733

PROPOSED PLAN VIEW  
 SCALE 1"=10'

APPROVED \_\_\_\_\_  
 DISAPPROVED \_\_\_\_\_  
 VARIANCE REQ \_\_\_\_\_

DYNAMIC ENGINEERING SOLUTIONS  
 1950 N.E. 6th Street #10075  
 Pompano Beach, FL 33061  
 Phone - 954-860-5262  
 Email - des\_inc@bellsouth.net  
 E.B. # 26829

JOB NAME  
**KLINGER RESIDENCE**  
**194 S ISLAND DR**  
**GOLDEN BEACH, FL 33160**

NEW CONCRETE SEAWALL CAP & NEW WOOD DOCK  
 W/24,000# CAPACITY BOAT LIFT & PWC-JET SKI LIFT

Elite Environmental  
 Permitting Service  
 234 Parkway Court  
 Greenacres Florida 33413  
 OFFICE: 772-834-5117  
 E-Mail tolley.tabatha@yahoo.com

DATE: 04/28/2022  
 REVISION: D  
 11/30/2022  
 S-4



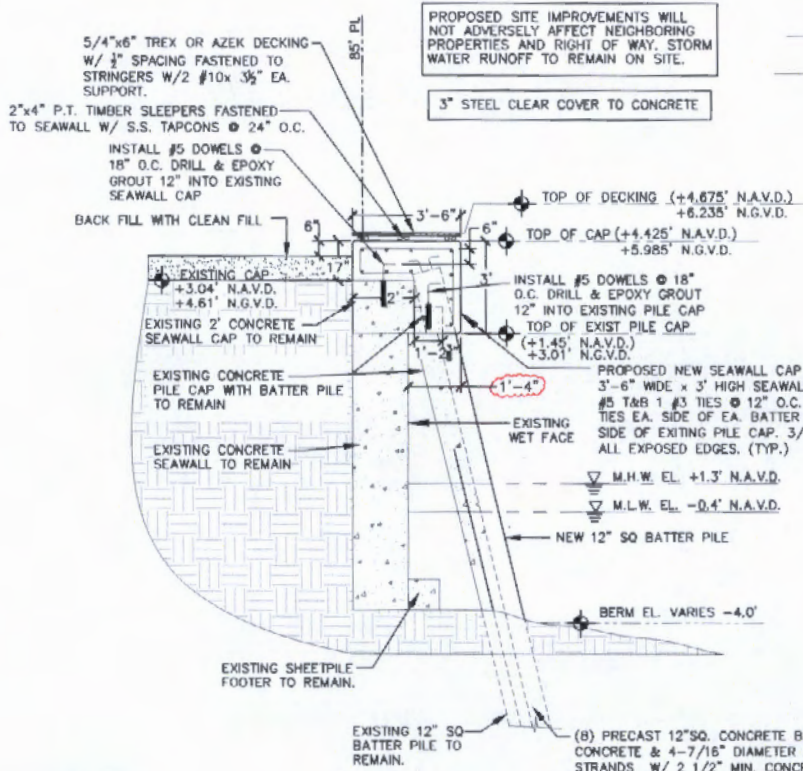

PROPOSED SITE IMPROVEMENTS WILL NOT ADVERSELY AFFECT NEIGHBORING PROPERTIES AND RIGHT OF WAY. STORM WATER RUNOFF TO REMAIN ON SITE.

3" STEEL CLEAR COVER TO CONCRETE

TOP OF DECKING (+4.675' N.A.V.D.)  
+6.235' N.G.V.D.  
TOP OF CAP (+4.425' N.A.V.D.)  
+5.985' N.G.V.D.

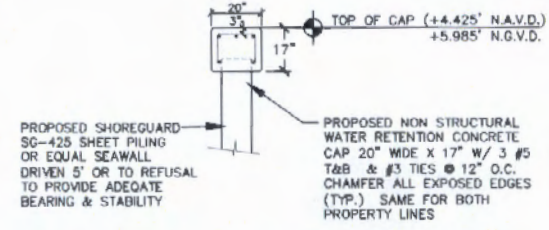

VIEW D  
RETURN-WALL DETAIL (TYP.)  
N.T.S.

VIEW A  
SEAWALL CAP  
1/4" = 1'

Town of Golden Beach  
Building Regulatory Advisory Board  
Hearing Date

JAN 11 2023

APPROVED \_\_\_\_\_  
DISAPPROVED \_\_\_\_\_  
VARIANCE REQ \_\_\_\_\_

"This document has been electronically signed and sealed by John H. Omslaer, P.E. on date noted using a SHA-1 authentication code. Printed copies are not considered signed and sealed and the SHA-1 authentication code must be verified on any electronic copies per Rule 62-30.060, F.A.C."

JOHN H. OMSLAER P.E. Date:  
Reg. Florida No. 52733

THE WORK SPECIFIED HEREIN HAS BEEN DESIGNED & ALL WORK SHALL BE IN ACCORDANCE WITH STRUCTURAL PROVISIONS OF THE 7th EDITION 2020 FLORIDA BUILDING CODE. BEST MANAGEMENT PRACTICES: FLOATING TURBIDITY CURTAIN EXTENDING WITHIN 1' OF BOTTOM TO BE INSTALLED DURING PILING INSTALLATION.

DYNAMIC ENGINEERING SOLUTIONS  
1950 N.E. 6th Street #10075  
Pompano Beach, FL 33061  
Phone - 954-860-5262  
Email - des\_inc@bellsouth.net  
E.B. # 26829

KLINGER RESIDENCE  
194 S ISLAND DR  
GOLDEN BEACH, FL 33160

NEW CONCRETE SEAWALL CAP & NEW WOOD DOCK  
W/24,000# CAPACITY BOAT LIFT & PWC-JET SKI LIFT

Elite Environmental  
Permitting Service  
234 Parkway Court  
Greenacres Florida 33413  
OFFICE: 772-834-5117  
E-Mail tolley.tabatha@yahoo.com

DATE 04/28/2022  
REVISION D  
11/30/2022  
S-5

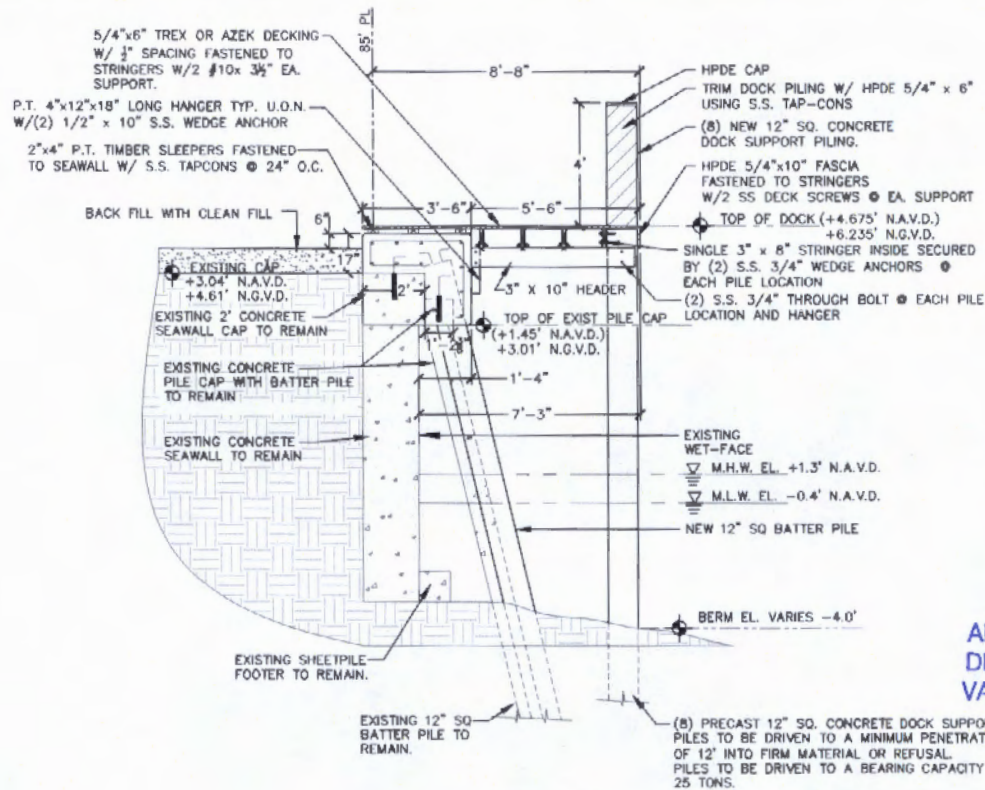

Town of Golden Beach  
Building Regulatory Advisory Board  
Hearing Date

JAN 11 2023

APPROVED \_\_\_\_\_  
DISAPPROVED \_\_\_\_\_  
VARIANCE REQ \_\_\_\_\_

VIEW B  
WOOD DOCK DETAIL

1/4"=1'

"This document has been electronically signed and sealed by John H. Omslaer, P.E. on date noted using a SHA-1 authentication code. Printed copies are not considered signed and sealed and the SHA-1 authentication code must be verified on any electronic copies per Rule 62-30.060, F.A.C."

JOHN H. OMSLAER P.E. Date:  
Reg. Florida No. 52733

THE WORK SPECIFIED HEREIN HAS BEEN DESIGNED & ALL WORK SHALL BE IN ACCORDANCE WITH STRUCTURAL PROVISIONS OF THE 7th EDITION 2020 FLORIDA BUILDING CODE. BEST MANAGEMENT PRACTICES: FLOATING TURBIDITY CURTAIN EXTENDING WITHIN 1' OF BOTTOM TO BE INSTALLED DURING PILING INSTALLATION.

DYNAMIC ENGINEERING SOLUTIONS  
1950 N.E. 6th Street #10075  
Pompano Beach, FL 33061  
Phone - 954-860-5262  
Email - des\_inc@bellsouth.net  
E.B. # 26829

KLINGER RESIDENCE  
194 S ISLAND DR  
GOLDEN BEACH, FL 33160

NEW CONCRETE SEAWALL CAP & NEW WOOD DOCK  
W/24,000# CAPACITY BOAT LIFT & PWC-JET SKI LIFT

Elite Environmental  
Permitting Service  
234 Parkway Court  
Greenacres Florida 33413  
OFFICE: 772-834-5117  
E-Mail toley.tabatha@yahoo.com

DATE 04/28/2022  
REVISION D  
11/30/2022  
S-6

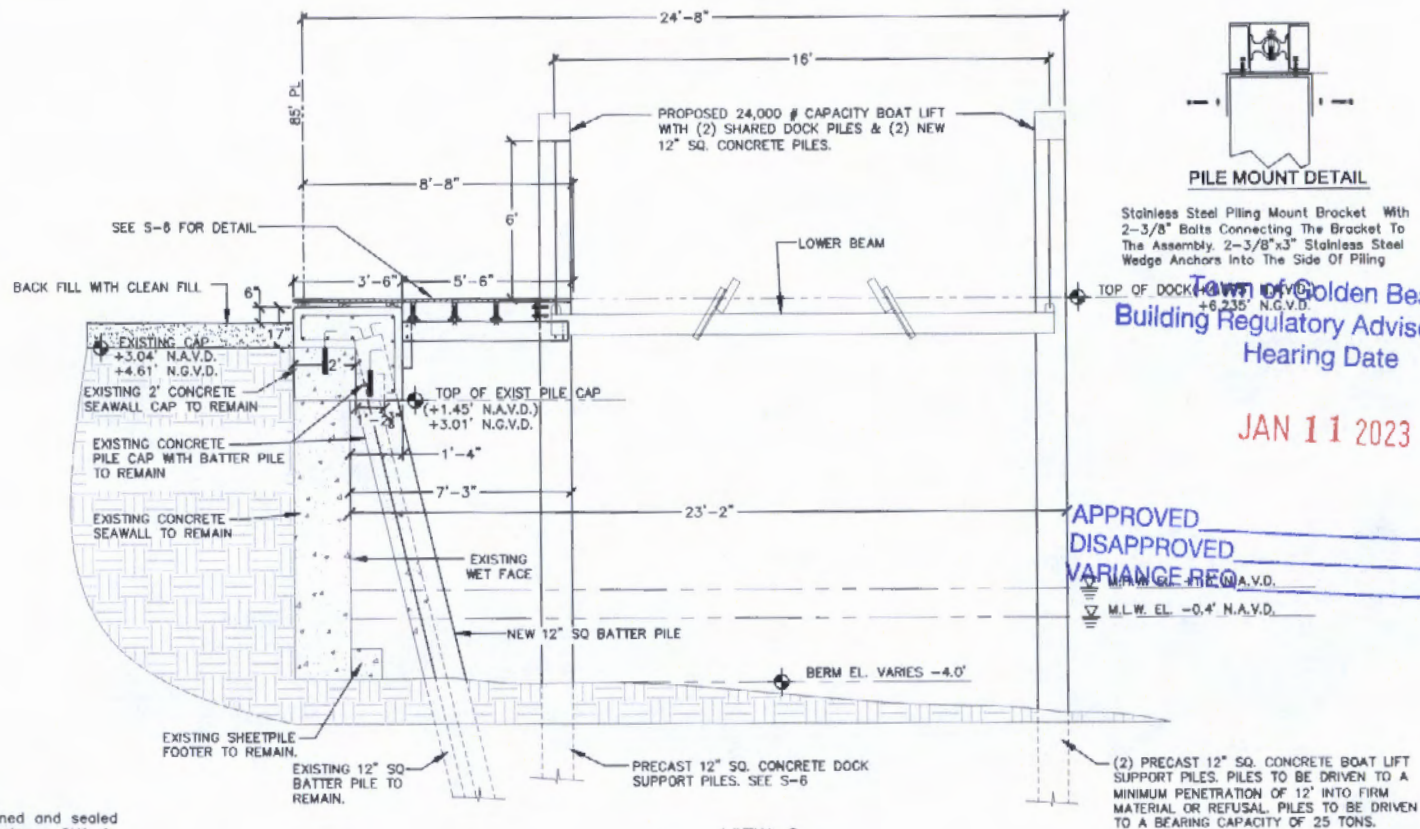

Town of Golden Beach  
 Building Regulatory Advisory Board  
 Hearing Date

JAN 11 2023

APPROVED  
 DISAPPROVED  
 VARIANCE REQ.

VIEW C  
 BOAT LIFT DETAIL  
 1/4" = 1'

"This document has been electronically signed and sealed by John H. Omslaer, P.E. on date noted using a SHA-1 authentication code. Printed copies are not considered signed and sealed and the SHA-1 authentication code must be verified on any electronic copies per Rule 62-30.060, F.A.C."

JOHN H. OMSLAER P.E. Date:  
 Reg. Florida No. 52733

THE WORK SPECIFIED HEREIN HAS BEEN DESIGNED & ALL WORK SHALL BE IN ACCORDANCE WITH STRUCTURAL PROVISIONS OF THE 7th EDITION 2020 FLORIDA BUILDING CODE. BEST MANAGEMENT PRACTICES: FLOATING TURBIDITY CURTAIN EXTENDING WITHIN 1' OF BOTTOM TO BE INSTALLED DURING PILING INSTALLATION.

DYNAMIC ENGINEERING SOLUTIONS  
 1950 N.E. 6th Street #10075  
 Pompano Beach, FL 33061  
 Phone - 954-860-5262  
 Email - des\_inc@bellsouth.net  
 E.B. # 26829

PROJECT NAME  
**KLINGER RESIDENCE**  
**194 S ISLAND DR**  
**GOLDEN BEACH, FL 33160**

NEW CONCRETE SEAWALL CAP & NEW WOOD DOCK  
 W/24,000# CAPACITY BOAT LIFT & PWC-JET SKI LIFT

Elite Environmental  
 Permitting Service  
 234 Parkway Court  
 Greenacres Florida 33413  
 OFFICE: 772-834-5117  
 E-Mail toley.tabatha@yahoo.com

DATE: 04/28/2022

REVISION: D

11/30/2022

S-7

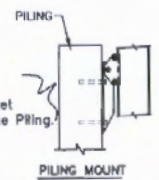
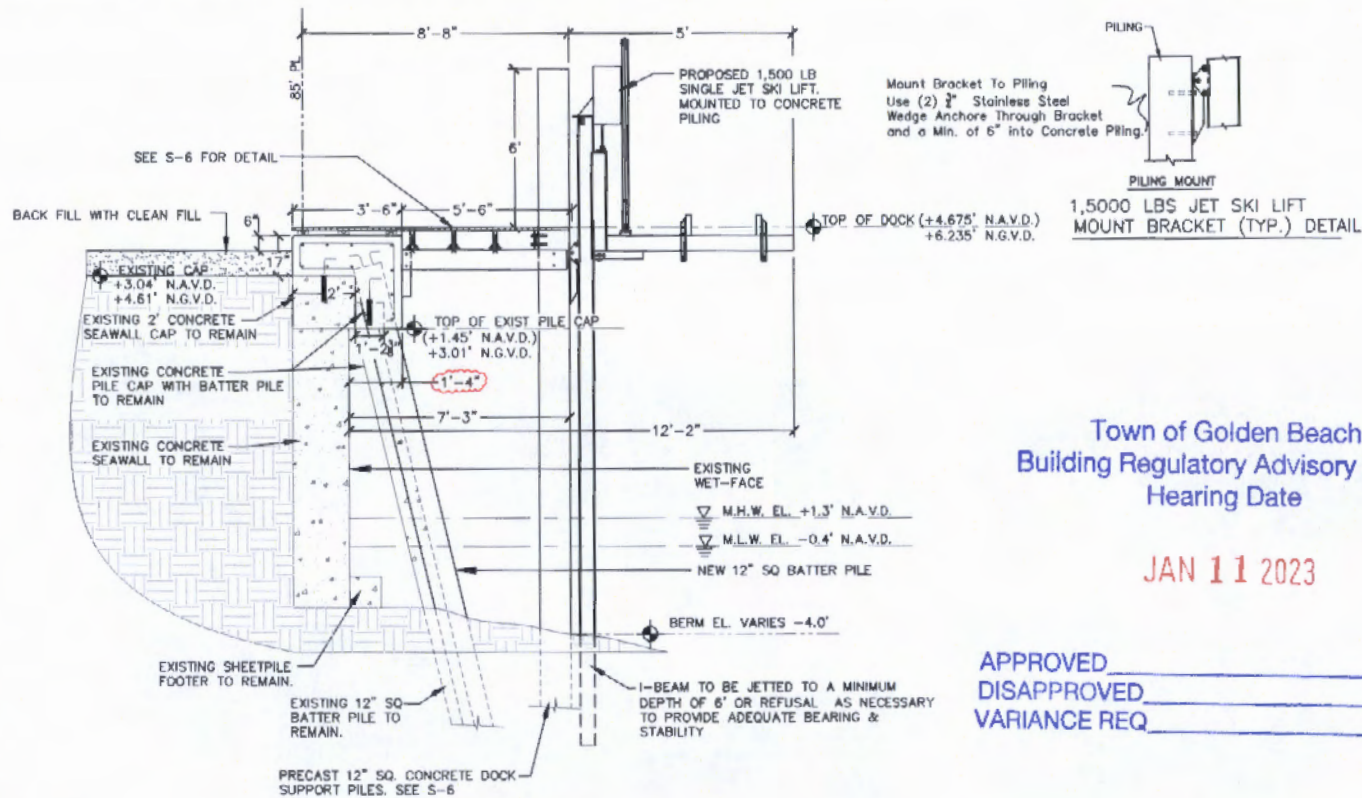

1,500 LBS JET SKI LIFT MOUNT BRACKET (TYP.) DETAIL

Town of Golden Beach  
 Building Regulatory Advisory Board  
 Hearing Date

JAN 11 2023

APPROVED \_\_\_\_\_  
 DISAPPROVED \_\_\_\_\_  
 VARIANCE REQ \_\_\_\_\_

VIEW E  
 PWC JET-SKI DETAIL  
 1/4" = 1'

"This document has been electronically signed and sealed by John H. Omslaer, P.E. on date noted using a SHA-1 authentication code. Printed copies are not considered signed and sealed and the SHA-1 authentication code must be verified on any electronic copies per Rule 62-30.060, F.A.C."

JOHN H. OMSLAER P.E. Date:  
 Reg. Florida No. 52733

THE WORK SPECIFIED HEREIN HAS BEEN DESIGNED & ALL WORK SHALL BE IN ACCORDANCE WITH STRUCTURAL PROVISIONS OF THE 7th EDITION 2020 FLORIDA BUILDING CODE. BEST MANAGEMENT PRACTICES: FLOATING TURBIDITY CURTAIN EXTENDING WITHIN 1' OF BOTTOM TO BE INSTALLED DURING PILING INSTALLATION.

DYNAMIC ENGINEERING SOLUTIONS  
 1950 N.E. 6th Street #10075  
 Pompano Beach, FL 33061  
 Phone - 954-860-5262  
 Email - des\_inc@bellsouth.net  
 E.B. # 26829

PROJECT: **KLINGER RESIDENCE**  
**194 S ISLAND DR**  
**GOLDEN BEACH, FL 33160**  
 NEW CONCRETE SEAWALL CAP & NEW WOOD DOCK  
 W/24,000# CAPACITY BOAT LIFT & PWC-JET SKI LIFT

Elite Environmental  
 Permitting Service  
 234 Parkway Court  
 Greenacres Florida 33413  
 OFFICE: 772-834-5117  
 E-Mail tolley.tabatha@yahoo.com

DATE: 04/28/2022  
 REVISION: D  
 11/30/2022  
 S-8

DECKING FASTENED TO STRINGERS W/#10x 3 1/2" SS DECK SCREWS @ EA. SUPPORT.

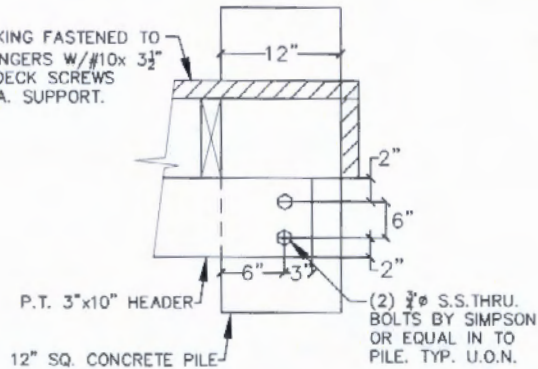

DECKING FASTENED TO STRINGERS W/#10x 3 1/2" SS DECK SCREWS @ EA. SUPPORT.

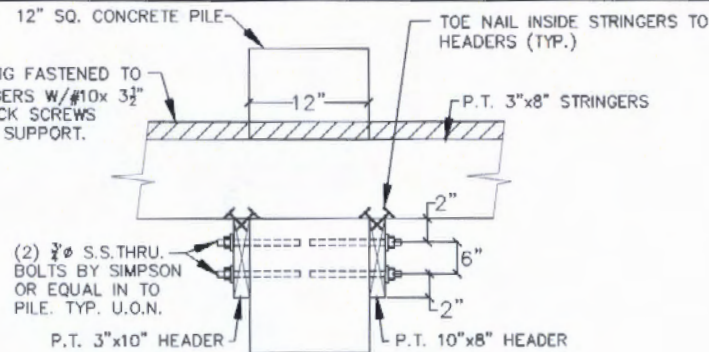

(TYP.) HEADER TO PILING DETAIL

1"=1"

P.T. 4"x12"x18" LONG HANGER TYP. U.O.N. FASTENED TO SEAWALL CAP

FASTENED TO SEAWALL CAP W/(2) 3/4" S.S. WEDGE ANCHORS BOLTS BY SIMPSON OR EQUAL INTO CAP. TYP. U.O.N.

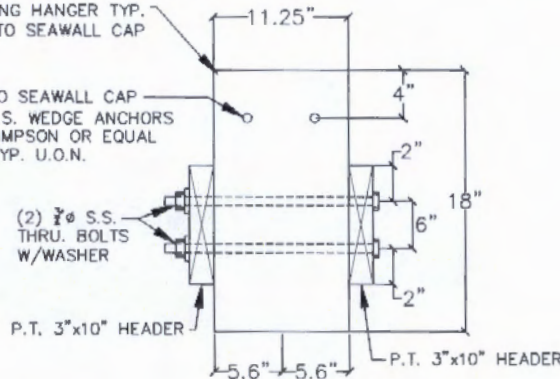

(TYP.) HANGER BLOCK DETAIL

1'=1'

Town of Golden Beach  
Building Regulatory Advisory Board  
Hearing Date

JAN 11 2023

APPROVED \_\_\_\_\_  
DISAPPROVED \_\_\_\_\_  
VARIANCE REQ \_\_\_\_\_

"This document has been electronically signed and sealed by John H. Omslaer, P.E. on date noted using a SHA-1 authentication code. Printed copies are not considered signed and sealed and the SHA-1 authentication code must be verified on any electronic copies per Rule 62-30.060, F.A.C."

JOHN H. OMSLAER P.E. Date:  
Reg. Florida No. 52733

THE WORK SPECIFIED HEREIN HAS BEEN DESIGNED & ALL WORK SHALL BE IN ACCORDANCE WITH STRUCTURAL PROVISIONS OF THE 7th EDITION 2020 FLORIDA BUILDING CODE. BEST MANAGEMENT PRACTICES: FLOATING TURBIDITY CURTAIN EXTENDING WITHIN 1' OF BOTTOM TO BE INSTALLED DURING PILING INSTALLATION.

DYNAMIC ENGINEERING SOLUTIONS  
1950 N.E. 6th Street #10075  
Pompano Beach, FL 33061  
Phone - 954-860-5262  
Email - des\_inc@bellsouth.net  
E.B. # 26829

JOB NO: **KLINGER RESIDENCE**  
**194 S ISLAND DR**  
**GOLDEN BEACH, FL 33160**

NEW CONCRETE SEAWALL CAP & NEW WOOD DOCK  
W/24,000# CAPACITY BOAT LIFT & PWC-JET SKI LIFT

Elite Environmental  
Permitting Service  
234 Parkway Court  
Greenacres Florida 33413  
OFFICE: 772-834-5117  
E-Mail tolley.tabatha@yahoo.com

DATE 04/28/2022

REVISION D

DATE 11/30/2022

S-9

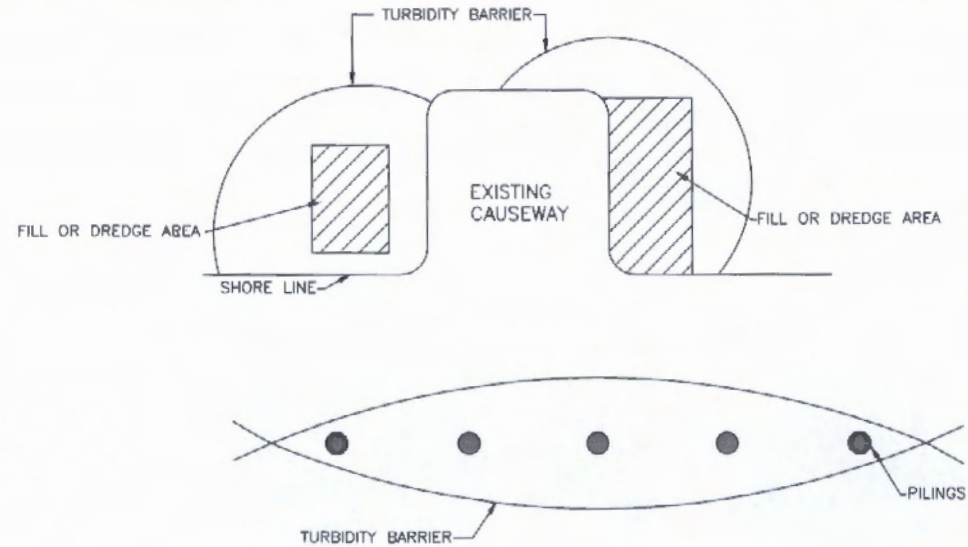
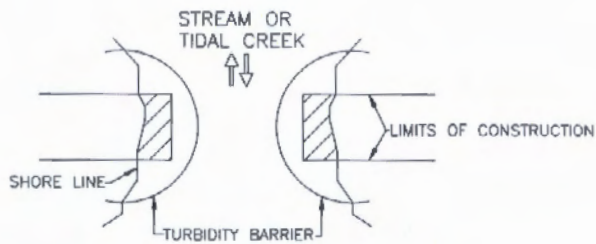

**NOTES**

1. TURBIDITY BARRIERS ARE TO BE USED IN ALL PERMANENT BODIES OF WATER REGARDLESS OF WATER DEPTH
2. NUMBER AND SPACING DEPENDANT ON CURRENT VELOCITIES.
3. DEPLOYMENT OF BARRIER AROUND PILE LOCATION MAY VARY TO ACCOMMODATE CONSTRUCTION OPERATIONS.
4. NAVIGATION MAY REQUIRE SEGMENTING BARRIER DURING CONSTRUCTION OPERATIONS.
5. FOR ADDITIONAL INFORMATION SEE SECTION 104 OF THE STANDARD SPECIFICATIONS.
6. TURBIDITY BARRIERS FOR FLOWING STREAMS AND TIDAL CREEKS MAY BE EITHER FLOATING OR STAKED TYPES.
7. BARRIER TYPE WILL BE AT THE CONTRACTOR'S DECISION U.N.O.
8. POSTS IN STAKED TURBIDITY BARRIERS TO BE INSTALLED IN VERTICAL POSITION UNLESS OTHERWISE DIRECTED BY ENGINEER.
9. N.P.D.E.S. INSPECTION TO BE CALLED FOR BY ENGINEER TO VERIFY TURBIDITY BARRIER.

Town of Golden Beach  
Building Regulatory Advisory Board  
Hearing Date

JAN 11 2023

APPROVED \_\_\_\_\_  
DISAPPROVED \_\_\_\_\_  
VARIANCE REQ \_\_\_\_\_

TURBIDITY CURTAIN DETAIL  
N.T.S.

"This document has been electronically signed and sealed by John H. Omslaer, P.E. on date noted using a SHA-1 authentication code. Printed copies are not considered signed and sealed and the SHA-1 authentication code must be verified on any electronic copies per Rule 62-30.060, F.A.C."

JOHN H. OMSLAER P.E.      Date:  
Reg. Florida No. 52733

DYNAMIC ENGINEERING SOLUTIONS  
1950 N.E. 6th Street #10075  
Pompano Beach, FL 33061  
Phone - 954-860-5262  
Email - des\_inc@bellsouth.net  
E.B. # 26829

**KLINGER RESIDENCE**  
**194 S ISLAND DR**  
**GOLDEN BEACH, FL 33160**

NEW CONCRETE SEAWALL CAP & NEW WOOD DOCK  
W/24,000# CAPACITY BOAT LIFT & PWC-JET SKI LIFT

Elite Environmental  
Permitting Service  
234 Parkway Court  
Greenacres Florida 33413  
OFFICE: 772-834-5117  
E-Mail tolley.tabatha@yahoo.com

DATE 04/28/2022  
REVISION D  
11/30/2022

S-10



**Subject:** RE: 194 South Island Variance Request  
**Date:** Wednesday, November 16, 2022 at 9:54:55 AM Eastern Standard Time  
**From:** Ricardo Kassin Nasser  
**To:** Michael Klinger  
**Attachments:** image001.jpg

Hello Michael,  
Thank you for the explanation this morning.

I confirm I do NOT object to this variance being approved.

All the best

Ricardo Kassin  
Managing Director  
Direct line (786)857-5410  
Operator (786)857-5400  
Fax (786)245-4666  
600 Brickell Avenue, Suite 1875  
Miami, FL 33131  
[Ricardo.kassin@alexbrown.com](mailto:Ricardo.kassin@alexbrown.com)  
<https://www.alexbrown.com/kassinwealth>

Town of Golden Beach  
Building Regulatory Advisory Board  
Hearing Date

JAN 11 2023

APPROVED \_\_\_\_\_  
DISAPPROVED \_\_\_\_\_  
VARIANCE REQ \_\_\_\_\_



---

**From:** Michael Klinger <klinger@saberfund.com>  
**Sent:** Tuesday, November 15, 2022 5:41 PM  
**To:** Ricardo Kassin Nasser <Ricardo.Kassin@AlexBrown.com>  
**Subject:** 194 South Island Variance Request

Richie,

How are you? I hope all is well. I was wondering if you can help me with something. As you may know, the Town of Golden Beach code dictates that upon a transfer of property seawalls need to be raised to 4.425' NAVD in order to combat flooding. I applied for a Building Regulatory Advisory Board approval for the raised seawall cap and new dock/boat lift permit for 194 South Island. The Town's review of the application came back with a few comments one of which was that the seawall encroaches outside the property line towards the water which makes it non-conforming to the current code requiring a variance. I imagine when it was first built that it met the code. So, the variance request results from the existing seawall encroaching 1' 8 3/4" outside of the property line and Town Code §46-86(b) requires that all nonconforming seawalls replaced entirely on the subject property unless a variance is granted per Town Code §46-81. As part of the application, they ask that I approach my adjacent neighbors and ask them for a letter of no objection to this petition. Would you be so kind as to respond to this e-mail confirming that you do not



object to this variance request? If you have any questions I would be happy to come by and explain further.

All the best,  
Michael

Michael Klinger  
Managing Member  
Saber Real Estate Advisors, LLC  
1820 E. Hallandale Beach Boulevard  
Hallandale Beach, FL 33009  
786-406-1762 (O)  
305-968-4468 (C)

Town of Golden Beach  
Building Regulatory Advisory Board  
Hearing Date

JAN 11 2023

APPROVED \_\_\_\_\_  
DISAPPROVED \_\_\_\_\_  
VARIANCE REQ \_\_\_\_\_

---

Disclosures Regarding this Email Communication (Including Any Attachments)

Please visit <http://www.raymondjames.com/smrja.htm> for Additional Risk and Disclosure Information. Alex. Brown, a division of Raymond James & Associates, Inc, Member NYSE/SIPC, does not accept private client orders or account instructions by email. This email: (a) is not an official transaction confirmation or account statement; (b) is not an offer, solicitation, or recommendation to transact in any security; (c) is intended only for the addressee; and (d) may not be retransmitted to, or used by, any other party. This email may contain confidential or privileged information; please delete immediately if you are not the intended recipient. Alex. Brown, a division of Raymond James, monitors emails and may be required by law or regulation to disclose emails to third parties.

Investment products are: Not deposits. Not FDIC insured. Not guaranteed by the financial institution. Subject to risk. May lose value.

**This may constitute a commercial email message under the CAN-SPAM Act of 2003. If you do not wish to receive marketing or advertising related email messages from us, please reply to this message with "unsubscribe" in your response. You will continue to receive emails from us related to servicing your account(s).**

---

Disclosures Regarding this Email Communication (Including Any Attachments)

Please visit <http://www.raymondjames.com/smrja.htm> for Additional Risk and Disclosure Information. Alex. Brown, a division of Raymond James & Associates, Inc, Member NYSE/SIPC, does not accept private client orders or account instructions by email. This email: (a) is not an official transaction confirmation or account statement; (b) is not an offer, solicitation, or recommendation to transact in any security; (c) is intended only for the addressee; and (d) may not be retransmitted to, or used by, any other party. This email may contain confidential or privileged information; please delete immediately if you are not the intended recipient. Alex. Brown, a division of Raymond James, monitors emails and may be required by law or regulation to disclose emails to third parties.

Investment products are: Not deposits. Not FDIC insured. Not guaranteed by the financial institution. Subject to risk. May lose value.

**This may constitute a commercial email message under the CAN-SPAM Act of 2003. If you do not wish to receive marketing or advertising related email messages from us, please reply to this message with "unsubscribe" in your response. You will continue to receive emails from us related to servicing your account(s).**

Prepared By:  
**Arie Mrejen**  
**Arie Mrejen, P.A.**  
**Harbour Centre - Suite 413**  
**18851 NE 29th Ave.**  
**Aventura, FL 33180**  
**(954) 771-3740**  
File No.: AMS-21-0252

Town of Golden Beach  
Building Regulatory Advisory Board  
Hearing Date

JAN 11 2023

Return to:  
**Bergman & Jacobs, P.A.**  
**2001 Hollywood Blvd., Suite 200**  
**Hollywood, FL 333020**

APPROVED \_\_\_\_\_  
DISAPPROVED \_\_\_\_\_  
VARIANCE REQ \_\_\_\_\_

Parcel Identification Number: 19-1235-004-0650

[Space Above This Line For Recording Data]

### WARRANTY DEED

This Warranty Deed Made this 15<sup>th</sup> day of November, 2021 by Evgeny Melashchenko joined by his spouse Yulia Shishina, hereinafter called the grantor, whose post office address is: 110 Hendricks Isle, Apt. 14, Ft. Lauderdale, FL 33301 to:

**Michael G. Klinger and Michelle Frohlich-Klinger, Husband and Wife** whose post office address is:  
**194 S. Island Drive, Golden Beach, FL 33160** hereinafter called the grantee,

**WITNESSETH:** That said grantor, for and in consideration of the sum of ten and no/100 (\$10.00), and other variable considerations, receipt whereof is hereby acknowledged, hereby grants, bargains, sells, aliens, remises, releases, conveys and confirms unto the grantee, all that certain land situated in **Miami-Dade County, Florida**, viz:

**Lot 26 and the South 35 feet of Lot 27, in Block J, of SECTION D OF GOLDEN BEACH, according to the plat thereof, as recorded in Plat Book 10, at Page 10, of the Public Records of Miami-Dade County, Florida.**

Parcel Identification Number: 19-1235-004-0650

**TOGETHER** with all the tenements, hereditaments and appurtenances thereto belonging or in anywise appertaining.

**To Have and to Hold**, the same in fee simple forever.

And the grantor hereby covenants with said grantee that the grantor is lawfully seized of said land in fee simple; that the grantor has good right and lawful authority to sell and convey said land; that the grantor hereby fully warrants the title to said land and will defend the same against the lawful claims of all persons whomsoever; and that said land is free of all encumbrances, except taxes accruing subsequent to 2020, reservations, restrictions and easements of record, if any.

(The terms "grantor" and "grantee" herein shall be construed to include all genders and singular or plural as the context indicates)

IN WITNESS WHEREOF, Grantor has hereunto set grantor's hand and seal the day and year first above written.

Signed, Sealed and Delivered in Our Presence:

Witness  
Print Name: ARIE MREJEN

Witness  
Print Name: Lena Zubkova

[Signature]  
Evgeny Melashchenko

[Signature]  
Yulia Shishina

STATE OF: FLORIDA  
COUNTY OF: MIAMI-DADE

The foregoing instrument was acknowledged before me by means of  physical presence or  online notarization, this 15<sup>th</sup> day of NOVEMBER 2021, by Evgeny Melashchenko and Yulia Shishina. They  are personally known to me or  have produced a driver's license as identification.

[Notary Seal]



[Signature]  
Notary Public  
Printed Name: \_\_\_\_\_  
My Commission Expires: \_\_\_\_\_

Town of Golden Beach  
Building Regulatory Advisory Board  
Hearing Date

JAN 11 2023

APPROVED \_\_\_\_\_  
DISAPPROVED \_\_\_\_\_  
VARIANCE REQ \_\_\_\_\_

ALBERTO FRANCO & W ROSSANA  
212 S ISLAND DR  
GOLDEN BEACH, FL 33160

120 SOUTH ISLAND LLC  
428 GOLDEN BEACH DR  
GOLDEN BEACH, FL 33160

IGOR ANAPOLSKY TRS  
IGOR ANAPOLSKY TRUST  
ANGELIKA ANAPOLSKY TRS  
210 S ISLAND DR  
GOLDEN BEACH, FL 33160

STEVEN BANDEL  
MINNIE BANDEL  
110 S ISLAND DR  
GOLDEN BEACH, FL 33160

MAXIE EZRATTI  
12717 WEST SUNRISE BLVD #415  
SUNRISE, FL 33323

JENNY IVCHER  
100 S ISLAND DR  
GOLDEN BEACH, FL 33160

RICARDO KASSIN  
198 S ISLAND DR  
GOLDEN BEACH, FL 33160

MARCOS LENCOVSKI & W SARA  
294 S ISLAND DR  
GOLDEN BEACH, FL 33160-0000

MICHAEL G KLINGER  
MICHELLE FROHLICH KLINGER  
194 S ISLAND DR  
GOLDEN BEACH, FL 33160

MANUEL GROSSKOPF  
MARIANA GROSSKOPF LEVI  
284 S ISLAND DR  
GOLDEN BEACH, FL 33160

INTRAMARINA PROPERTIES LTD  
% LOEB BLOCK & PARTNERS LLC  
136 GOLDEN BEACH DR  
GOLDEN BEACH, FL 33160

692 265 ONTARIO LTD  
1 BRENDAN COURT  
THORNHILL ONTARIO L3T  
5T8,CANADA

DANIEL ADES  
GISELA ADES  
1010 S FEDERAL HWY STE 2900  
HALLANDALE BEACH, FL 33009

SERGIO STIBERMAN & W KEILA  
124 S ISLAND DR  
GOLDEN BEACH, FL 33160

PAUL S GROLL & CHERYL GROLL  
170 S ISLAND DR  
GOLDEN BEACH, FL 33160

F. **VARIANCE REQUEST(S):**

13. Ronni and Paul Bianco  
448 Golden Beach Drive  
Golden Beach, FL 33160

Property Address: 448 Golden Beach Drive, Golden Beach, FL 33160  
Folio No: 19-1235-005-0470  
Legal Description: S10ft Lot 38 & All Lot 39 & Lot 40 less S25 ft BK F GB Sec E PB 8-122

Christopher Gratz – Zoning Reviewer for the Town summarized his report and it was entered into the record.

Robert Shan – 134 S Dixie Highway, Hallandale Beach, FL. – spoke on behalf of the applicant

Installation dock replacement, seawall repair and boatlift.

Relief from Town Code Sec. 46-81. - Extension of seawalls into waterways.  
No part of any seawall, including slabs may extend beyond any lot property line into any waterway in the Town. The piles and cap beam may encroach into the waterway, if approved by the agency having jurisdiction.

Request is to allow the new seawall to encroach outside the property line, approximately 4.38', into the waterway.

In accordance with Town Code Section 66-41, "authorized, general procedure", pertaining to variances, the board considered all evidence and testimony presented by the applicant, the public and the Town and made a finding that the applicant has complied with the seven criteria.

A motion was made to recommend approval by Stephanie Halfen, Seconded by Isaac Murciano.

On roll call – Zvi Shiff-Aye, Isaac Murciano-Aye, Jerome Hollo-Aye and Stephanie Halfen-Aye.

Motion passed 4 – 0

14. Michael G Klinger  
Michelle Frohlich Klinger  
194 South Island Drive  
Golden Beach, FL 33160

Property Address: 194 South Island Drive, Golden Beach, FL 33160  
Folio No: 19-1235-004-0650  
Legal Description: S35ft Lot 27, BK J GB Sec D PB 10-10

Christopher Gratz – Zoning reviewer for the Town summarized his report and it was entered into the record.

Michael Klinger owner of the property spoke on his own behalf.

Installation of a dock replacement, seawall repair and boatlift

Relief from Town Code Sec. 46-81. - Extension of seawalls into waterways.

No part of any seawall, including slabs may extend beyond any lot property line into any waterway in the Town. The piles and cap beam may encroach into the waterway, if approved by the agency having jurisdiction.

Request is to allow the new seawall to encroach, approximately 1'-8 ¾", outside the property line into the waterway.

In accordance with Town Code Section 66-41, "authorized, general procedure", pertaining to variances, the board considered all evidence and testimony presented by the applicant, the public and the Town and made a finding that the applicant has complied with the seven criteria.

A motion was made to recommend approval by Isaac Murciano, Seconded by Zvi Shiff. On roll call – Zvi Shiff-Aye, Isaac Murciano-Aye, Jerome Hollo-Aye and Stephanie Halfen-Aye.

Motion passed 4 – 0

**G. NEW BUSINESS:**

15. Ronni and Paul Bianco  
448 Golden Beach Drive  
Golden Beach, FL 33160

Property Address: 448 Golden Beach Drive, Golden Beach, FL 33160  
Folio No: 19-1235-005-0470  
Legal Description: S10ft Lot 38 & All Lot 39 & Lot 40 less S25 ft BK F GB Sec E PB 8-122

Christopher Gratz' report was entered into the record.  
Robert Shan represented the applicant.

Installation dock replacement, seawall repair and boatlift.

A motion was made by Stephanie Halfen to approve the item, conditioned on the Town Council's approval of the variance request, Seconded by Isaac Murciano.

On roll call – Zvi Shiff-Aye, Isaac Murciano-Aye, Jerome Hollo-Aye and Stephanie Halfen-Aye.

Motion passed 4 – 0

16. Michael G Klinger  
Michelle Frohlich Klinger  
194 South Island Drive  
Golden Beach, FL 33160

Property Address: 194 South Island Drive, Golden Beach, FL 33160  
Folio No: 19-1235-004-0650  
Legal Description: S35ft Lot 27, BK J GB Sec D PB 10-10

Christopher Gratz' report was entered into the record  
Mr. Klinger – owner of the property was present.

Installation dock replacement, seawall repair and boatlift

A motion was made by Stephanie Halfen to approve the item, conditioned on the Town Council's approval of the variance request, Seconded by Isaac Murciano.

On roll call – Zvi Shiff-Aye, Isaac Murciano-Aye, Jerome Hollo-Aye and Stephanie Halfen-Aye.

Motion passed 4 – 0

**H. PRELIMINARY DESIGN REVIEWS - ITEMS FOR DISCUSSION AND POSSIBLE APPROVAL**

**I. ADJOURNMENT**

PURSUANT TO FLA. STATUTE 286.0106, THE TOWN HEREBY ADVISES THE PUBLIC THAT: IF A PERSON DECIDES TO APPEAL ANY DECISION MADE BY THIS BOARD WITH RESPECT TO ANY MATTER CONSIDERED AT ITS MEETING OR HEARING, HE WILL NEED A RECORD OF THE PROCEEDINGS, AND FOR THAT SUCH PURPOSE, AFFECTED PERSONS MAY NEED TO ENSURE THAT A VERBATIM RECORD OF THE PROCEEDINGS IS MADE, WHICH RECORD INCLUDES THE TESTIMONY AND EVIDENCE UPON WHICH THE APPEAL IS TO BE BASED. THIS NOTICE DOES NOT CONSTITUTE CONSENT BY THE TOWN FOR THE INTRODUCTION OR ADMISSION OF OTHER INADMISSIBLE OR IRRELEVANT EVIDENCE, NOR DOES I



TOWN OF GOLDEN BEACH  
1 Golden Beach Drive  
Golden Beach, Fl. 33160

Summary Minutes "DRAFT"  
BUILDING REGULATION ADVISORY BOARD  
January 10, 2023 at 6pm

Zoom Meeting ID: 892 9110 8015 Passcode: 752288 For Dial in only call: 929-205-6099

- A. **CALL MEETING TO ORDER:** 6:00pm
- B. **BOARD ATTENDANCE:** Avi Shiff, Isaac Murciano, Jerome Hollo and Stephanie Halfen  
**Absent:** Eric Cohen, Judy Mimoun and Alan Macken
- C. **STAFF ATTENDANCE:** Linda Epperson-Assistant Town Manager and Christopher Gratz – Zoning Reviewer.
- D. **APPROVAL OF MINUTES:** December 13, 2022

Motion to approve the minutes by Zvi Shiff, Seconded by Isaac Murciano  
All were in favor – no one opposed  
Motion passed 4 – 0

E. **REQUEST FOR ADDITIONS, DEFERRALS, DELETIONS & WITHDRAWALS:**

**Moving items 8 and 9 to new business**

- 1. Faris A Hanna  
150 Golden Beach Dr.  
Golden Beach, FL 33160-2241

Property Address: 150 Golden Beach Dr, Golden Beach, Fl 33160-2241  
Folio No: 19-1235-004-0260  
Legal Description: Lot -8 & 9, Block H, GB Sect D, PB 10-10

New seawall and timber boat dock.

- 2. 310 South Parkway LLC  
310 S Parkway  
Golden Beach, FL 33160

Property Address: 310 South Parkway, Golden Beach, FL, 33160  
Folio No: 19-1235-005-0590  
Legal Description: Lot 31 & 32, Block G, GB Sect E, PB 8-122

Installation dock replacement & seawall repair.

- 3. 200 Golden Beach LLC  
17201 Collins Ave 3501  
Sunny Isles Beach, FL 33160



Property Address: 200 Golden Beach, Golden Beach, FL 33160-2215  
Folio No: 19-1235-004-0010  
Legal Description: Lot 1 & 2, Blk G GB Sec D, PB 10-10

Construction of a new single-family residence and landscape design approval.

4. Adam Brian Glazer  
Carmen Isbely Glazer  
19973 NE 37 Ave  
Aventura, FL 33180

Property Address: Vacant Lot A/K/A, 624 Ocean Blvd., Golden Beach, FL 33160  
Folio No: 19-1235-001-0080  
Legal Description: Lot 8 & S1/2 of Lot 9, Blk 1, GB Sect A, PB 9-52

Construction of a new single-family residence design approval.

5. Center Island LLC  
393 Center Island Drive  
Golden Beach, FL 33009 USA

Property Address: 397 Center Island Drive, Golden Beach, FL 33160  
Folio No: 19-1235-005-0885  
Legal Description: Lot 24 Less S12 50 FT & Lot 25 Blk GB Sec E PB 8-122

Construction of a new single-family residence and landscape design approval.

6. Center Island LLC  
393 Center Island Drive  
Golden Beach, FL 33009 USA

Property Address: 393 Center Island Drive, Golden Beach, FL 33160  
Folio No: 19-1235-005-0880  
Legal Description: Lot 22 & Lot 23 Blk GB Sec E PB 8-122

Construction of a new single-family residence and landscape design approval.

7. Tariq Smith and Audra Schnepf Cherif  
530 North Parkway  
Golden Beach, FL 33160

Property Address: 530 North Parkway, Golden Beach, FL 33160  
Folio No: 19-1235-006-0710  
Legal Description: Lot -17, Block F GB Sect F, PB 10-11

Installation of boatlift.

8. Jose A De Paula Torres Lima  
Marcia C Nogueira Torres Lima  
547 Golden Beach Drive  
Golden Beach, FL 33160-2215

Property Address: 547 Golden Beach, Golden Beach, FL 33160-2215  
Folio No: 19-1235-006-0250  
Legal Description: Lot 25 & 26, Blk 2 GB Sec F, PB 10-11

Construction of a new single-family residence and landscape design approval.

9. Allegro Acquisitions Corp.  
343 Center Island Drive  
Golden Beach, FL. 33160

Property Address: 343 Center Island Drive, GB, FL. 33160  
Folio No: 19-1235-005-0820  
Legal Description: Lot 11, Block K, GB Section E, PB 8-122

New seawall and dock

10. Allegretto Holdings LLC.  
5150 Tamiami Trail, North 302  
Naples, FL. 34103

Property Address: 345 Center Island Drive, GB, FL. 33160  
Folio No: 19-1235-005-0830  
Legal Description: Lot 12, Block K, GB Section E, PB 8-122

New seawall and dock

11. Allegro Acquisitions Corp.  
349 Center Island Drive  
Golden Beach, FL. 33160

Property Address: 349 Center Island Drive, GB, FL. 33160  
Folio No: 19-1235-005-0840  
Legal Description: Lot 13 & Beg NE Cor of Lot 14 SW 150' NW 21.237' along s/l of  
Lot 14 NE 150.15' E7.35' to POB, Block K, GB Sect E, B 8-122

New seawall and dock

12. David M. Lazarus Trs.  
88 Terracina Land Trust  
20295 NE 29<sup>th</sup> Place, Suite 200  
Aventura, Fl. 33180

Property Address: 88 Terracina Avenue, Golden Beach, FL. 33160  
Folio No: 19-1235-004-0350  
Legal Description: Lots 23 & 24, Block H, GB Sect D, PB 10-10

Addition, interior/exterior remodel to an existing residence.

Motion by Zvi Shiff to defer items 1 through 12 to the next Building Advisory Board meeting, Seconded by Isaac Murciano  
On roll call – Zvi Shiff-Aye, Isaac Murciano-Aye, Jerome Hollo-Aye and Stephanie Halfen-Aye.  
Motion passed 4 – 0