

**TOWN OF GOLDEN BEACH, FLORIDA**

**RESOLUTION NO. 2749.21**

**A RESOLUTION OF THE TOWN COUNCIL OF THE TOWN OF GOLDEN BEACH, FLORIDA, APPROVING AN AGREEMENT WITH SOUTHEASTERN ENGINEERING CONTRACTORS, INC. FOR THE TWEDDLE PARK STORMWATER OUTFALL FITTINGS REPLACEMENT; AUTHORIZING THE MAYOR TO EXECUTE THE AGREEMENT; PROVIDING FOR IMPLEMENTATION; AND PROVIDING FOR AN EFFECTIVE DATE.**

**WHEREAS**, the Town Council of the Town of Golden Beach, Florida (the "Town") has an ongoing capital improvement program that includes stormwater improvements throughout the Town; and

**WHEREAS**, the Town tasked Craig A. Smith & Associates (CAS) with obtaining price proposals from qualified contractors to address the lost discharge capacity of the existing drainage wells at Tweddle Park, by replacing the existing stormwater outfall fittings; and

**WHEREAS**, CAS received three (3) price proposals and upon evaluation of each of the proposals recommended the Project be awarded to Southeastern Engineering Contractors, Inc. (the "Contractor") as having the lowest, most responsive-responsible price proposal; and,

**WHEREAS**, after careful consideration of the recommendation by Craig A. Smith & Associates, Inc. and the evaluation criteria, the Town Council wishes to award the Project to the Contractor in accordance with the agreement, attached to this Resolution as Exhibit "A," (the "Agreement"); and

**NOW, THEREFORE, BE IT RESOLVED BY THE TOWN COUNCIL OF THE TOWN OF GOLDEN BEACH, FLORIDA, AS FOLLOWS:**

**Section 1. Recitals Adopted.** Each of the above stated recitals are hereby adopted, confirmed and incorporated herein.

**Section 2. Approval of Agreement.** The Town Council hereby awards the Project to the Contractor and approves the Agreement.

**Section 3. Implementation.** The Mayor is hereby authorized to execute the Agreement after approval by the Town Attorney, and the Mayor and Town Manager are hereby authorized to take all steps reasonably necessary to implement the Agreement and this Resolution.

**Section 4. Effective Date.** This Resolution shall be effective immediately upon adoption.

The Motion to adopt the foregoing Resolution was offered by Councilmember Mendal, seconded by Councilmember Einstein and on roll call the following vote ensued:

|                                 |            |
|---------------------------------|------------|
| Mayor Glenn Singer              | <u>Aye</u> |
| Vice Mayor Judy Lusskin         | <u>Aye</u> |
| Councilmember Bernard Einstein  | <u>Aye</u> |
| Councilmember Jaime Mendal      | <u>Aye</u> |
| Councilmember Kenneth Bernstein | <u>Aye</u> |

**PASSED AND ADOPTED** by the Town Council of the Town of Golden Beach, Florida, this 15<sup>th</sup> day of June, 2021.

  
\_\_\_\_\_  
MAYOR GLENN SINGER

ATTEST:

  
\_\_\_\_\_  
LISSETTE PEREZ  
TOWN CLERK

APPROVED AS TO FORM  
AND LEGAL SUFFICIENCY:

  
\_\_\_\_\_  
STEPHEN J. HELFMAN  
TOWN ATTORNEY



# TOWN OF GOLDEN BEACH

One Golden Beach Drive  
Golden Beach, FL 33160

---

## MEMORANDUM

---

**Date:** June 15, 2021

Item Number:

**To:** Honorable Mayor Glenn Singer &  
Town Council Members

9

**From:** Alexander Diaz,  
Town Manager

**Subject:** **Resolution No. 2749.21 – Approving contract with  
Southeastern Engineering Contractors for the Tweddle Park  
Stormwater Outfall Fittings Replacement**

---

### **Recommendation:**

It is recommended that the Town Council adopt the attached Resolution No. 2749.21 as presented.

### **Background:**

The drainage well at Tweddle Park has had a significant loss (approx. 90%) in drainage capacity. This has caused the majority of the discharge to be diverted to the existing gravity outfall. In the best effort to reduce flooding at the tennis courts and adjacent areas, we believe the proposed repair to the gravity outfall will improve the rate of discharge.

The work entails the replacement of existing fittings near 147 Golden Beach Drive with new fittings to improve the hydraulics of the existing stormwater gravity outfall and includes the adjustment of the manhole opposite of this location with a new top slab with sealed lids (see sketch below for work location) to keep lids from surcharging.

As we worked towards a solution to address the lost discharge capacity of the existing drainage wells at Tweddle Park and in order to ensure we have obtained competitive pricing, Craig A. Smith & Associates (CAS) requested and received three (3) price proposals from qualified contractors that can perform the requested work.

Southeastern Engineering Contractors (SEC) is quite familiar with the Town's infrastructure as they were the successful bidder awarded the Town's capital

improvement project, drainage systems, potable water systems, completion of an existing stormwater pumping station (North Park), and the full construction of the South Park Pump Station (both stations designed and permitted by CAS). In addition, they are currently installing the Town's Center Island Pump Station. Based on our review, SEC has the lowest and most responsive-responsible price proposal. Town staff and CAS hereby recommends the award for to SEC based on the price and previous track record.

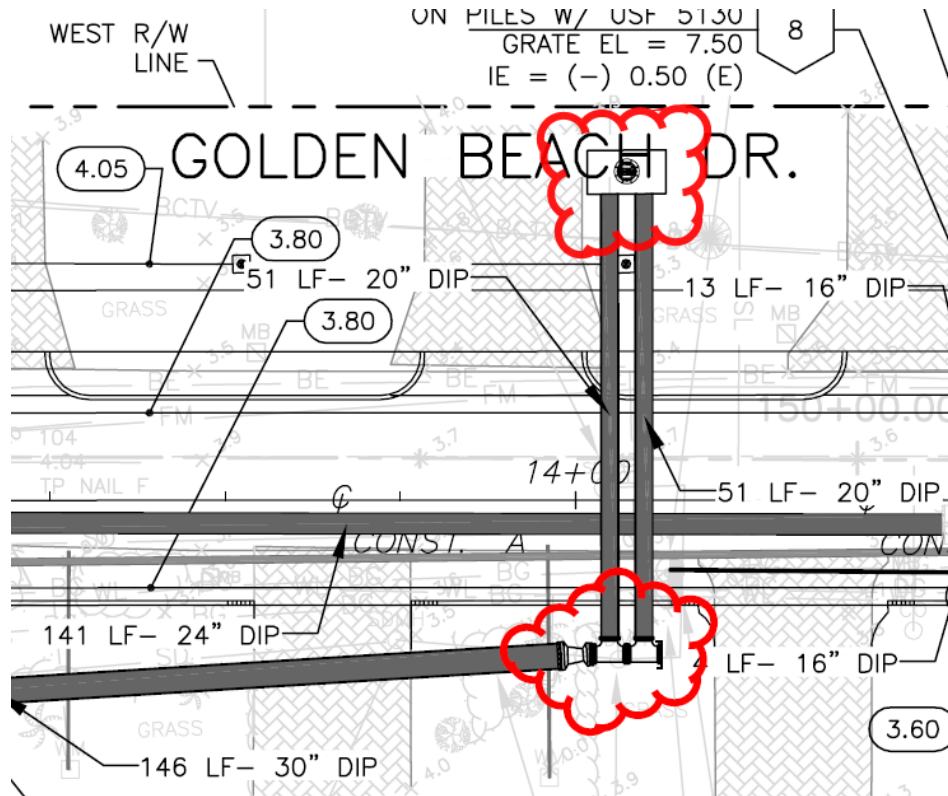

**Fiscal Impact:**

The fiscal impact for this project is \$78,500.00. These funds will come from the Contingency Fund and will be due to the General Fund from the Stormwater Fund.



# CRAIG A. SMITH & ASSOCIATES

21045 Commercial Trail • Boca Raton, FL 33486

CONSULTING ENGINEERS • SURVEYORS • UTILITY LOCATORS

www.craigasmith.com

April 21, 2021

Alexander Diaz, Town Manager  
1 Golden Beach Drive  
Golden Beach, Florida 33160

(via e-mail)

**RE: Town of Golden Beach - Tweddle Park Stormwater Outfall Fittings Replacement  
PRICE PROPOSAL RECOMMENDATION  
CAS PROJECT NO. 16-0944-STMWTR**

Dear Mr. Diaz:

As we worked towards a solution to address the lost discharge capacity of the existing drainage wells at Tweddle Park and in order to ensure we have obtained competitive pricing, Craig A. Smith & Associates (CAS) requested and received three (3) price proposals from qualified contractors that can perform the requested work. The work entails the replacement of existing fittings near 147 Golden Beach Drive with new fittings to improve the hydraulics of the existing stormwater gravity outfall and includes the adjustment of the manhole opposite of this location with a new top slab with sealed lids (see sketch below for work location) to keep lids from surcharging.

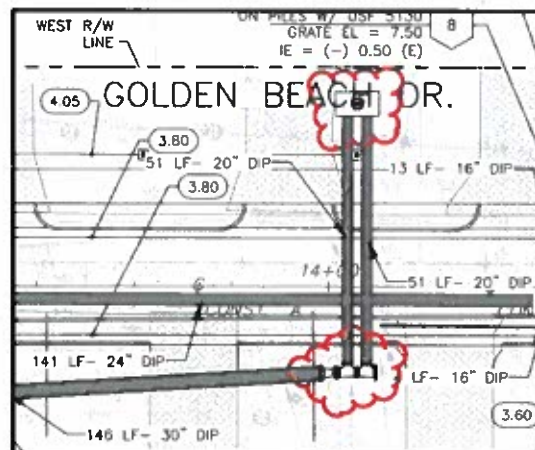

Price proposals were received from the following contractors.

1. Southeastern Engineering Contractors (SEC): \$78,500.00.
2. Shenandoah: \$148,220.00.
3. David Mancini & Sons, Inc.: \$100,000.00.

SEC's price is much lower than other proposers and this could be attributed to the fact that they are currently mobilized and constructing the Center Island Pump Station project having forces already in place to perform the work. SEC is quite familiar with the Town's infrastructure as they were the successful bidder awarded the Town's capital improvement project around 2010 consisting of road work, drainage systems, potable water systems, completion of an existing stormwater pumping station (North Park) and the full construction of the South Park Pump Station (both stations designed and permitted by CAS).

Based on our review, SEC has the lowest and most responsive-responsible price proposal and CAS hereby recommends the award for \$78,500.00 to SEC based on the price and previous track record.

Alexander Diaz, Town Manager  
RE: Town of Golden Beach - Tweddle Park Stormwater Outfall Fittings Replacement  
Page | 2

We look forward to working with the Town and SEC on a successful project. Please contact me at the letterhead numbers shown or by electronic mail at [orubio@craigasmith.com](mailto:orubio@craigasmith.com) should you have any questions or require any additional information.

Sincerely,

**CRAIG A. SMITH & ASSOCIATES, INC.**



Orlando A. Rubio, PE  
Sr. Supervising Engineer

Enclosures; Contractors' Price Proposals

Cc: TGB – Alexander Diaz, Town Manager; Maria Camacho, CFO; Lissett Rovira; Lissette Perez (via email)  
CAS – Stephen C. Smith, PE, Tony Gomes (via e-mail), File

\\cas-file\Projects\Cities\_Villages\_Towns\Golden\_Beach\08-1465-GB\_DRAINAGE\TWEDDLE PARK\TweddleParkOutfallFittings\Bid Recommendation for TGB\_TPFittings.docx



| PROPOSAL              |                                             |                        |      |                  |                  |
|-----------------------|---------------------------------------------|------------------------|------|------------------|------------------|
| PROJECT DESCRIPTION:  |                                             | TOWN OF GOLDEN BEACH   |      | DATE: 02/09/2021 |                  |
| FINANCIAL PROJECT ID: |                                             | Drainage Modifications |      |                  |                  |
| PROJECT NO.: N/A      |                                             |                        |      |                  |                  |
| ITEM                  |                                             | UNIT                   | QTY. | UNIT PRICE       | TOTAL AMOUNT     |
| 1                     | Mobilization and General Items              | LS                     | 1.00 | 1,800.00         | 1,800.00         |
| 2                     | Soft Digging                                | LS                     | 1.00 | 5,500.00         | 5,500.00         |
| 3                     | Furnish and Install Pipe and Fittings       | LS                     | 1.00 | 55,400.00        | 55,400.00        |
| 4                     | Remove and Replace MH Top Slab with a Riser | LS                     | 1.00 | 11,600.00        | 11,600.00        |
| 5                     | Cleaning                                    | LS                     | 1.00 | 1,200.00         | 1,200.00         |
| 6                     | Restoration                                 | LS                     | 1.00 | 3,000.00         | 3,000.00         |
|                       |                                             |                        |      | <b>TOTAL</b>     | <b>78,500.00</b> |

**Payment Terms:**

The price(s) quoted here are based on the quantities/measurements stated above. Any change in measurement or quantity may result in a price adjustment. Customer agrees to pay interest on past due payments at the highest rates allowed by law from when payment is due until payment is received by Southeastern. Customer agrees to pay all costs of collections due to non payment and reasonable attorney fees of the contractor in any effort to collect moneys under this agreement. All prices quoted are good for 30 days.

**Exclusions:** Permit fees unless specifically accounted for above. HOA fees, landscape restoration or any other work not specifically listed or described in this proposal. If you do not see an item of work described above please do not assume that it is accounted for.

**If needed, Town to provide for police services at no cost to SEC.**

**All work to be performed during daylight hours. Add 1.5 x labor costs for night work.**

No restoration or repairs work such as landscaping, irrigation, etc., etc. is included in above items.

Minimum charge for concrete is \$2,800

Submitted by: Southeastern Engineering Contractors, Inc.  
911 NW 209th Avenue, Suite 101  
Pembroke Pines, FL 33029

Accepted by:

  
Alexander Diaz, Town Manager  
Town of Golden Beach





April 21, 2021

Alexander Diaz, Town Manager  
1 Golden Beach Drive  
Golden Beach, Florida 33160

(via e-mail)

**RE: Town of Golden Beach - Tweddle Park Stormwater Outfall Fittings Replacement  
PRICE PROPOSAL RECOMMENDATION  
CAS PROJECT NO. 16-0944-STMWTR**

Dear Mr. Diaz:

As we worked towards a solution to address the lost discharge capacity of the existing drainage wells at Tweddle Park and in order to ensure we have obtained competitive pricing, Craig A. Smith & Associates (CAS) requested and received three (3) price proposals from qualified contractors that can perform the requested work. The work entails the replacement of existing fittings near 147 Golden Beach Drive with new fittings to improve the hydraulics of the existing stormwater gravity outfall and includes the adjustment of the manhole opposite of this location with a new top slab with sealed lids (see sketch below for work location) to keep lids from surcharging.

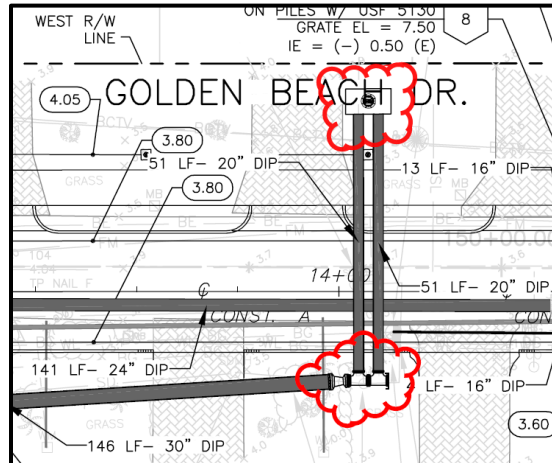

Price proposals were received from the following contractors.

1. Southeastern Engineering Contractors (SEC): \$78,500.00.
2. Shenandoah: \$148,220.00.
3. David Mancini & Sons, Inc.: \$100,000.00.

SEC's price is much lower than other proposers and this could be attributed to the fact that they are currently mobilized and constructing the Center Island Pump Station project having forces already in place to perform the work. SEC is quite familiar with the Town's infrastructure as they were the successful bidder awarded the Town's capital improvement project around 2010 consisting of road work, drainage systems, potable water systems, completion of an existing stormwater pumping station (North Park) and the full construction of the South Park Pump Station (both stations designed and permitted by CAS).

Based on our review, SEC has the lowest and most responsive-responsible price proposal and CAS hereby recommends the award for \$78,500.00 to SEC based on the price and previous track record.



We look forward to working with the Town and SEC on a successful project. Please contact me at the letterhead numbers shown or by electronic mail at [orubio@craigasmith.com](mailto:orubio@craigasmith.com) should you have any questions or require any additional information.

Sincerely,

**CRAIG A. SMITH & ASSOCIATES, INC.**



Orlando A. Rubio, PE  
Sr. Supervising Engineer

Enclosures; Contractors' Price Proposals

Cc: TGB – Alexander Diaz, Town Manager; Maria Camacho, CFO; Lissett Rovira; Lisette Perez (via email)  
CAS – Stephen C. Smith, PE, Tony Gomes (via e-mail), File

\\cas-file\Projects\Cities\_Villages\_Towns\Golden\_Beach\08-1465-GB\_DRAINAGE\TWEDDLE PARK\TweddleParkOutfallFittings\Bid Recommendation for TGB\_TPFittings.docx



| PROPOSAL              |                                             |                        |      |                  |                  |
|-----------------------|---------------------------------------------|------------------------|------|------------------|------------------|
| PROJECT DESCRIPTION:  |                                             | TOWN OF GOLDEN BEACH   |      | DATE: 02/09/2021 |                  |
| FINANCIAL PROJECT ID: |                                             | Drainage Modifications |      |                  |                  |
| PROJECT NO.:          |                                             | N/A                    |      |                  |                  |
| ITEM                  |                                             | UNIT                   | QTY. | UNIT PRICE       | TOTAL AMOUNT     |
| 1                     | Mobilization and General Items              | LS                     | 1.00 | 1,800.00         | 1,800.00         |
| 2                     | Soft Digging                                | LS                     | 1.00 | 5,500.00         | 5,500.00         |
| 3                     | Furnish and Install Pipe and Fittings       | LS                     | 1.00 | 55,400.00        | 55,400.00        |
| 4                     | Remove and Replace MH Top Slab with a Riser | LS                     | 1.00 | 11,600.00        | 11,600.00        |
| 5                     | Cleaning                                    | LS                     | 1.00 | 1,200.00         | 1,200.00         |
| 6                     | Restoration                                 | LS                     | 1.00 | 3,000.00         | 3,000.00         |
|                       |                                             |                        |      | <b>TOTAL</b>     | <b>78,500.00</b> |

**Payment Terms:**

The price(s) quoted here are based on the quantities/measurements stated above. Any change in measurement or quantity may result in a price adjustment. Customer agrees to pay interest on past due payments at the highest rates allowed by law from when payment is due until payment is received by Southeastern. Customer agrees to pay all costs of collections due to non payment and reasonable attorney fees of the contractor in any effort to collect moneys under this agreement. All prices quoted are good for 30 days.

**Exclusions:** Permit fees unless specifically accounted for above, HOA fees, landscape restoration or any other work not specifically listed or described in this proposal. If you do not see an item of work described above please do not assume that it is accounted for.

**If needed, Town to provide for police services at no cost to SEC.**

**All work to be performed during daylight hours. Add 1.5 x labor costs for night work.**

No restoration or repairs work such as landscaping, irrigation, etc., etc. is included in above items.

Minimum charge for concrete is \$2,800

Submitted by: **Southeastern Engineering Contractors, Inc.**  
 911 NW 209th Avenue, Suite 101  
 Pembroke Pines, FL 33029

Accepted by: \_\_\_\_\_  
 \_\_\_\_\_  
 Town of Golden Beach



1888 NW 22nd Street  
(954) 975-0098

Pipe Inspection & Restoration Specialist

Pompano Beach, FL, 33069  
shenandoahus.com

DATE: April 02, 2021  
SUBMITTED TO: Craig A. Smith  
STREET: 21045 Commercial Trail  
CITY, STATE & ZIP: Boca Raton, FL 33486  
PHONE: (561) 314-4445  
FAX:  
EMAIL: acaruso@craigasmith.com  
JOB NAME: Tweddle Park Pumpstation Outfall  
Fittings replacement  
ATTENTION: Al Caruso

PROPOSAL #P21343

We propose to furnish a crew and all necessary equipment to remove and re-install fittings as shown on sketch provided by engineer at the above mentioned job location. This work will be performed at our following hourly and/or unit prices:

|                                           |                            |             |                     |
|-------------------------------------------|----------------------------|-------------|---------------------|
| 1 - F&I DIP fittings                      | (at \$145,220.00 Lump Sum) | 1 Lump Sum  | \$145,220.00        |
| 2 - Utility conflict allowance (Optional) | (at \$3,000.00 Allowance)  | 1 Allowance | \$3,000.00          |
| <b>Estimated Total:</b>                   |                            |             | <b>\$148,220.00</b> |

Notes: Includes daytime work 7am to 5pm

NOTE: Shenandoah Construction is not an engineering firm nor does it assume responsibility for any engineering design; therefore, we offer this proposal as our professional recommendation and interpretation of what could potentially work for the client or owner needs. By accepting this proposal, the client or owner accepts Shenandoah Construction recommendations to proceed with the work as described above.

This proposal may be withdrawn if not accepted within 30 days. Payment terms net 30 days.  
(If we encounter an Insurance compliance fee requirement, this fee will be invoiced in addition to the above rates.)

SIGNATURE:

SHENANDOAH GENERAL CONSTRUCTION CO.  
Robson Lima

TITLE  
Estimator

DATE  
04/02/2021

ACCEPTANCE OF PROPOSAL / SIGN & RETURN

The above prices, specification and conditions are satisfactory and are hereby accepted. You are authorized to do the work as specified.

SIGNATURE: \_\_\_\_\_

COMPANY NAME:  
REPRESENTATIVE:

DATE:  
TITLE:

**REQUEST FOR PROPOSAL # 001**



2601 Wiles Rd Pompano Beach Florida 33073  
PH: (954) 977-3556 FAX: (954) 944-2040

PROJECT #: TOWN OF GOLDEN BEACH  
CONTRACTOR: David Mancini & Sons, Inc. (DMSI)  
Date: 4/20/2021

*Description: Furnishing and installation of pipes, fittings and accessories to perform the pipe adjustment shown in the marked As-Builts ((Drawing # 1 and 2) and top slab modifications to Structure # 46A (Drawing # 4).  
Location: Golden Beach Drive Sta. 14+00*

**SUMMARY OF DIRECT COSTS**

| ITEM                      | DESCRIPTION OF WORK                                       | UNIT | QUANTITY | TOTAL                |
|---------------------------|-----------------------------------------------------------|------|----------|----------------------|
| 1                         | General Conditions                                        | LS   | 1.00     | 100,000.00           |
| 2                         | Mobilization                                              | LS   | 1.00     |                      |
| 3                         | Discharge pipe modification (Pipes, fitting, accessories) | LS   | 1.00     |                      |
| 4                         | Manhole Modification                                      | LS   | 1.00     |                      |
| 5                         | Backfill and Temporary Restoration                        | LS   | 1.00     |                      |
| <b><u>Grand Total</u></b> |                                                           |      |          | <b>\$ 100,000.00</b> |

Sincerely,



Fabio Angarita