

**TOWN OF GOLDEN BEACH, FLORIDA**

**RESOLUTION NO. 2951.24**

**A RESOLUTION OF THE TOWN COUNCIL OF THE TOWN OF GOLDEN BEACH, FLORIDA, APPROVING THE PROPOSAL PROVIDED BY SOUTHEASTERN ENGINEERING CONTRACTORS, INC. FOR THE INSTALLATION OF A 36" WASTOP VALVE FOR THE SOUTH ISLAND OUTFALL, IN AN AMOUNT NOT TO EXCEED \$37,150.00; PROVIDING FOR IMPLEMENTATION; AND PROVIDING FOR AN EFFECTIVE DATE.**

**WHEREAS**, the Town's Engineers have determined that check valve at the Stormwater Outfall on South Island needs to be replaced; and

**WHEREAS**, the malfunction of the valve allows high tide water to reverse and infiltrate into the storm drains, causing flooding in the Town's streets; and

**WHEREAS**, the Administration is recommending that we install a 36" Wastop valve; and

**WHEREAS**, the Town Council has determined that installing the 36" Wastop valve as recommended by the Town Manager is in the best interest of the Town; and

**WHEREAS**, the Town Council has determined that the proposal submitted by Southeastern Engineering Contractors, Inc. attached hereto as Exhibit "A," (the "Proposal") for an amount not to exceed \$37,150.00 is acceptable and will well serve the needs of the Town residents.

**NOW, THEREFORE, BE IT RESOLVED BY THE TOWN COUNCIL OF THE TOWN OF GOLDEN BEACH, FLORIDA, AS FOLLOWS:**

**Section 1. Recitals Adopted.** Each of the above stated recitals are hereby adopted and confirmed.

**Section 2. Proposal Approved.** The Town Council hereby approves the Proposal.

**Section 3. Implementation.** The Town Mayor and Town Manager are hereby directed to take all steps necessary to implement this Resolution, including the execution of the Proposal and/or contract approval by the Town Attorney.

**Section 4. Effective Date.** This Resolution shall be effective immediately upon adoption.

The Motion to adopt the foregoing Resolution was offered by Councilmember Mendal, seconded by Councilmember Lusskin and on roll call the following vote ensued:

Mayor Glenn Singer	<u>Aye</u>
Vice Mayor Bernard Einstein	<u>Aye</u>
Councilmember Judy Lusskin	<u>Aye</u>
Councilmember Kenneth Bernstein	<u>Aye</u>
Councilmember Jaime Mendal	<u>Aye</u>

**PASSED AND ADOPTED** by the Town Council of the Town of Golden Beach, Florida, this 18<sup>th</sup> day June, 2024.

  
MAYOR GLENN SINGER

ATTEST:

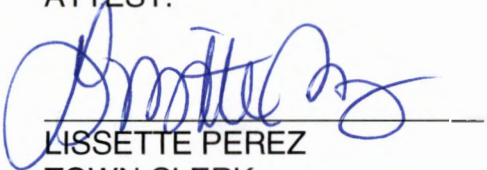
  
LISSETTE PEREZ  
TOWN CLERK

APPROVED AS TO FORM  
AND LEGAL SUFFICIENCY:

  
STEPHEN J. HELFMAN  
TOWN ATTORNEY

# RESO 2951.24 EXHIBIT A



PROPOSAL					
PROJECT DESCRIPTION:		TOWN OF GOLDEN BEACH			DATE: 02/23/24
FINANCIAL PROJECT ID:		South Parkway Outfall 36" Wastop Valve Installation			
PROJECT NO.: N/A		ISLAND			
ITEM	DESCRIPTION	UNIT	QTY.	UNIT PRICE	TOTAL AMOUNT
<b>Furnish and Install 1ea 36" Inline Valve (Wastop)</b>					
1	Mobilization	LS	1.00	1,900.00	1,900.00
2	MOT/ Safety / Erosion Control	LS	1.00	700.00	750.00
3	Remove Top Slab of Structure and Existing Valve, Cleaning	LS	1.00	4,200.00	4,200.00
4	Furnish & Install 36in Inline Check Valve	LS	1.00	26,700.00	26,700.00
5	Reinstall Top Slab, Sealing, and Restoration	LS	1.00	3,600.00	3,600.00
<b>TOTAL</b>					<b>37,150.00</b>

**Payment Terms:**

The price(s) quoted here are based on the quantities/measurements stated above. Any change in measurement or quantity may result in a price adjustment. Customer agrees to pay interest on past due payments at the highest rates allowed by law from when payment is due until payment is received by Southeastern. Customer agrees to pay all costs of collections due to non payment and reasonable attorney fees of the contractor in any effort to collect moneys under this agreement. All prices quoted are good for 30 days.

**Exclusions:** Permit fees unless specifically accounted for above, HOA fees, landscape restoration or any other work not specifically listed or described in this proposal. If you do not see an item of work described above please do not assume that it is accounted for.

Cost of restoration work (other than sod) of affected areas is to be priced by SEC and approved by the Town prior to SEC performing the restoration work. No restoration or repairs work such as landscaping, irrigation, etc., etc. is included in above items.

Minimum charge for concrete is \$3,150

Submitted Southeastern Engineering Contractors, Inc.  
911 NW 209th Avenue, Suite 101  
Pembroke Pines, Fl. 33029

  
 Accepted by:  
 Town of Golden Beach

PO 24519

		Created By	Appr By	Appr Date
A	Initial release	AE	PW	2020-02-06

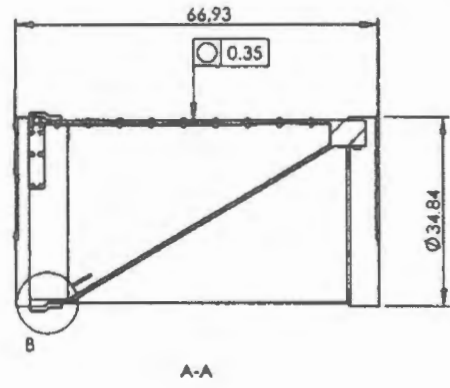
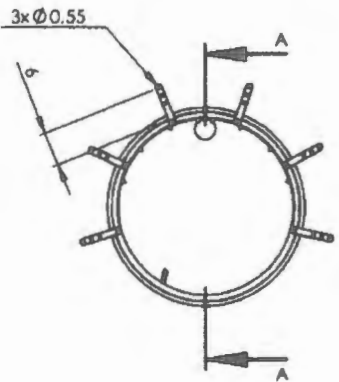

DETAIL B  
SCALE 1:5

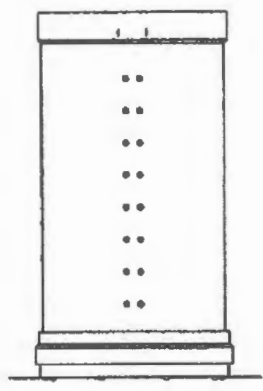
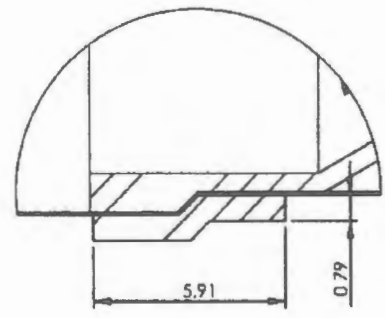

Designed By AE	Approved By PW	Created Date 2020-02-06	Units [mm]	General Tolerance ± 0.13920A	Scale 1	 Comments
Material AISI 304 AIS 316L			Description Wap-top NPS 36"			
Weight [Lbs] 272		Box Volume [ft³]		 www.wapro.com		
Article Number W5885 5		Drawing Number W5885-5-US		Rev A		Sheet 1/1



# TOWN OF GOLDEN BEACH

One Golden Beach Drive  
Golden Beach, FL 33160

---

## MEMORANDUM

---

**Date:** June 18, 2024

**To:** Honorable Mayor Glenn Singer &  
Town Council Members

**From:** Alexander Diaz,   
Town Manager

**Subject:** **Resolution No. 2951.24 – Authorizing and approving the scope of work for Southeastern Engineering Contractors, Inc. for the installation of a 36” Wastop valve for the South Island outfall.**

Item Number:

8

---

### **Recommendation:**

It is recommended that the Town Council adopt the attached Resolution No. 2951.24 as presented.

### **Background:**

The stormwater outfall on South Island has been inspected by our Town Engineers, who found that the check valve has cracked. The deterioration of the valve allows high tide water to reverse and infiltrate into the storm drains and structures, causing flood water in the streets. It is imperative to replace the Wastop valve as we enter hurricane and king tide season.

The attached Exhibit A is a complete breakdown of all items for council review.

### **Fiscal Impact:**

The installation has a fiscal impact of \$37,150.00, which will come from the stormwater fund.